

**Nokia Customer Care**

# ***Service Manual***

**RH-64 (Nokia 1600)**  
**Mobile Terminal**  
*Part No: (9243363 (Issue 1))*

***Company Confidential***

**NOKIA**

**Amendment Record Sheet**

<b>Amendment No</b>	<b>Date</b>	<b>Inserted By</b>	<b>Comments</b>
Original issue	07/2005	G Rudh	

## Copyright

Copyright © 2005 Nokia. All rights reserved.

Reproduction, transfer, distribution or storage of part or all of the contents in this document in any form without the prior written permission of Nokia is prohibited.

Nokia, Nokia Connecting People, and Nokia X and Y are trademarks or registered trademarks of Nokia Corporation. Other product and company names mentioned herein may be trademarks or tradenames of their respective owners.

Nokia operates a policy of continuous development. Nokia reserves the right to make changes and improvements to any of the products described in this document without prior notice.

Under no circumstances shall Nokia be responsible for any loss of data or income or any special, incidental, consequential or indirect damages howsoever caused.

The contents of this document are provided “as is”. Except as required by applicable law, no warranties of any kind, either express or implied, including, but not limited to, the implied warranties of merchantability and fitness for a particular purpose, are made in relation to the accuracy, reliability or contents of this document. Nokia reserves the right to revise this document or withdraw it at any time without prior notice.

The availability of particular products may vary by region.

## **IMPORTANT**

This document is intended for use by qualified service personnel only.

## Warnings and cautions

### Warnings

- IF THE DEVICE CAN BE INSTALLED IN A VEHICLE, CARE MUST BE TAKEN ON INSTALLATION IN VEHICLES FITTED WITH ELECTRONIC ENGINE MANAGEMENT SYSTEMS AND ANTI-SKID BRAKING SYSTEMS. UNDER CERTAIN FAULT CONDITIONS, EMITTED RF ENERGY CAN AFFECT THEIR OPERATION. IF NECESSARY, CONSULT THE VEHICLE DEALER/ MANUFACTURER TO DETERMINE THE IMMUNITY OF VEHICLE ELECTRONIC SYSTEMS TO RF ENERGY.
- THE PRODUCT MUST NOT BE OPERATED IN AREAS LIKELY TO CONTAIN POTENTIALLY EXPLOSIVE ATMOSPHERES, FOR EXAMPLE, PETROL STATIONS (SERVICE STATIONS), BLASTING AREAS ETC.
- OPERATION OF ANY RADIO TRANSMITTING EQUIPMENT, INCLUDING CELLULAR TELEPHONES, MAY INTERFERE WITH THE FUNCTIONALITY OF INADEQUATELY PROTECTED MEDICAL DEVICES. CONSULT A PHYSICIAN OR THE MANUFACTURER OF THE MEDICAL DEVICE IF YOU HAVE ANY QUESTIONS. OTHER ELECTRONIC EQUIPMENT MAY ALSO BE SUBJECT TO INTERFERENCE.
- BEFORE MAKING ANY TEST CONNECTIONS, MAKE SURE YOU HAVE SWITCHED OFF ALL EQUIPMENT.

### Cautions

- Servicing and alignment must be undertaken by qualified personnel only.
  - Ensure all work is carried out at an anti-static workstation and that an anti-static wrist strap is worn.
  - Ensure solder, wire, or foreign matter does not enter the telephone as damage may result.
  - Use only approved components as specified in the parts list.
  - Ensure all components, modules, screws and insulators are correctly re-fitted after servicing and alignment. Ensure all cables and wires are repositioned correctly.
- Use only approved components as specified in the parts list.
- Never test a mobile phone WCDMA transmitter with full Tx power, if there is no possibility to perform the measurements in a good performance RF-shielded room. Even low power WCDMA transmitters may disturb nearby WCDMA networks and cause problems to 3G cellular phone communication in a wide area.
  - During testing never activate the GSM or WCDMA transmitter without a proper antenna load, otherwise GSM or WCDMA PA may be damaged.

## **For your safety**

### **QUALIFIED SERVICE**

Only qualified personnel may install or repair phone equipment.

### **ACCESSORIES AND BATTERIES**

Use only approved accessories and batteries. Do not connect incompatible products.

### **CONNECTING TO OTHER DEVICES**

When connecting to any other device, read its user's guide for detailed safety instructions. Do not connect incompatible products.

## Care and maintenance

This product is of superior design and craftsmanship and should be treated with care. The suggestions below will help you to fulfil any warranty obligations and to enjoy this product for many years.

- Keep the phone and all its parts and accessories out of the reach of small children.
- Keep the phone dry. Precipitation, humidity and all types of liquids or moisture can contain minerals that will corrode electronic circuits.
- Do not use or store the phone in dusty, dirty areas. Its moving parts can be damaged.
- Do not store the phone in hot areas. High temperatures can shorten the life of electronic devices, damage batteries, and warp or melt certain plastics.
- Do not store the phone in cold areas. When it warms up (to its normal temperature), moisture can form inside, which may damage electronic circuit boards.
- Do not drop, knock or shake the phone. Rough handling can break internal circuit boards.
- Do not use harsh chemicals, cleaning solvents, or strong detergents to clean the phone.
- Do not paint the phone. Paint can clog the moving parts and prevent proper operation.
- Use only the supplied or an approved replacement antenna. Unauthorised antennas, modifications or attachments could damage the phone and may violate regulations governing radio devices.

All of the above suggestions apply equally to the product, battery, charger or any accessory.

## **ESD protection**

Nokia requires that service points have sufficient ESD protection (against static electricity) when servicing the phone.

Any product of which the covers are removed must be handled with ESD protection. The SIM card can be replaced without ESD protection if the product is otherwise ready for use.

To replace the covers ESD protection must be applied.

All electronic parts of the product are susceptible to ESD. Resistors, too, can be damaged by static electricity discharge.

All ESD sensitive parts must be packed in metallized protective bags during shipping and handling outside any ESD Protected Area (EPA).

Every repair action involving opening the product or handling the product components must be done under ESD protection.

ESD protected spare part packages **MUST NOT** be opened/closed out of an ESD Protected Area.

For more information and local requirements about ESD protection and ESD Protected Area, contact your local Nokia After Market Services representative.

## Battery information

**Note:** A new battery's full performance is achieved only after two or three complete charge and discharge cycles!

The battery can be charged and discharged hundreds of times but it will eventually wear out. When the operating time (talk-time and standby time) is noticeably shorter than normal, it is time to buy a new battery.

Use only batteries approved by the phone manufacturer and recharge the battery only with the chargers approved by the manufacturer. Unplug the charger when not in use. Do not leave the battery connected to a charger for longer than a week, since overcharging may shorten its lifetime. If left unused a fully charged battery will discharge itself over time.

Temperature extremes can affect the ability of your battery to charge.

For good operation times with Ni-Cd/NiMh batteries, discharge the battery from time to time by leaving the product switched on until it turns itself off (or by using the battery discharge facility of any approved accessory available for the product). Do not attempt to discharge the battery by any other means.

Use the battery only for its intended purpose.

Never use any charger or battery which is damaged.

Do not short-circuit the battery. Accidental short-circuiting can occur when a metallic object (coin, clip or pen) causes direct connection of the + and - terminals of the battery (metal strips on the battery) for example when you carry a spare battery in your pocket or purse. Short-circuiting the terminals may damage the battery or the connecting object.

Leaving the battery in hot or cold places, such as in a closed car in summer or winter conditions, will reduce the capacity and lifetime of the battery. Always try to keep the battery between 15°C and 25°C (59°F and 77°F). A phone with a hot or cold battery may temporarily not work, even when the battery is fully charged. Batteries' performance is particularly limited in temperatures well below freezing.

Do not dispose of batteries in a fire!

Dispose of batteries according to local regulations (e.g. recycling). Do not dispose as household waste.



## Company Policy

Our policy is of continuous development; details of all technical modifications will be included with service bulletins.

While every endeavour has been made to ensure the accuracy of this document, some errors may exist. If any errors are found by the reader, NOKIA MOBILE PHONES Business Group should be notified in writing/e-mail.

Please state:

- Title of the Document + Issue Number/Date of publication
- Latest Amendment Number (if applicable)
- Page(s) and/or Figure(s) in error

### **Please send to:**

NOKIA CORPORATION

Nokia Mobile Phones Business Group

Nokia Customer Care

PO Box 86

FIN-24101 SALO

Finland

E-mail: [Service.Manuals@nokia.com](mailto:Service.Manuals@nokia.com)

(This page left intentionally blank.)

## **Nokia 1600 Service Manual Structure**

- 1 General information
- 2 Parts and layouts
- 3 Phoenix service software
- 4 Service tools and concepts
- 5 Disassembly and reassembly instructions
- 6 Baseband troubleshooting
- 7 RF troubleshooting
- 8 System module
- 9 Schematics

(This page left intentionally blank.)

# Nokia Customer Care

## 1 — General information

(This page left intentionally blank.)

## Table of Contents

Product selection.....	1-5
Display and keypad features.....	1-5
Features.....	1-5
Hardware features.....	1-5
Software features.....	1-5
UI features.....	1-6
Mobile enhancements.....	1-6
Technical specifications.....	1-7
General specifications.....	1-7
Battery endurance.....	1-7
Environmental conditions.....	1-8
Electrical characteristics.....	1-8

### List of Tables

Table 1 Power.....	1-6
Table 2 Car.....	1-7
Table 3 Audio.....	1-7
Table 4 Xpress-on™ covers.....	1-7
Table 5 Normal and extreme voltages.....	1-8
Table 6 Current consumption.....	1-9

### List of Figures

Figure 1 RH-64 product picture.....	1-5
-------------------------------------	-----

(This page left intentionally blank.)



## ■ Product selection

The RH-64 has a dual band transceiver unit designed for the GSM900 and GSM1800 networks.



Figure 1 RH-64 product picture

## ■ Display and keypad features

- High resolution CSTN display (96x68 pixels) with 65,536 colors
- 4UI-style, 5-way navigation key including selection key,
- Hardtop keymat

## ■ Features

### Hardware features

- GSM E900/1800
- AMR/HR/FR/EFR codecs
- Internal antenna
- Charger plug
- Headset connector
- Internal vibrator
- User changeable front- and back covers and top cap
- SIM (1.8 and 3.0 V)

### Software features

- OS: CUI
- UI Style: Jack 4
- MIDP 2.0 Java, with latest APIs
- 20 polyphonic ringing tones

## UI features

Messaging	<ul style="list-style-type: none"> <li>• Multimedia messaging: send and receive messages containing text, an audio clip, and an image to other compatible devices (maximum message size: up to 100kB)</li> <li>• SMS messaging</li> <li>• Predictive text input</li> <li>• Asia-Pacific: English, Chinese Simplified, Chinese Traditional, Thai, Philipino, Vietnamese, Bahasa Indonesia, Bahasa Malaysia, Hindi</li> <li>• Europe and Africa: Danish, Dutch, English, French, Finnish, German, Icelandic, Italian, Portugese, Spanish, Swedish, Norwegian, Turkish, Greek, Bulgarian, Ukranian, Hebrew, Arabic, Slovakian, Czech, Hungarian, Polish, Romanian, Serbian, Croatian, Slovenian, Russian, Estonian, Latvian, Lithuanian</li> <li>• Non-predictive text input: Urdu, Farsi, Zulu, Xhosa, Sesotho, Swahili, Merathi, Tamil, Gujarati, Bengali</li> </ul>
Memory functions	<ul style="list-style-type: none"> <li>• Phone book (up to 300 entries)</li> </ul>
Connectivity	<ul style="list-style-type: none"> <li>• Plug and play connector</li> </ul>
Call management	<ul style="list-style-type: none"> <li>• Speed dialing: up to 8 names (keys 2-9)</li> <li>• Last number redial from dialed calls list (dial key brings out the dialed calls list)</li> <li>• Automatic redial (max 10 attempts)</li> <li>• Automatic answer (works with headset or car kit only)</li> <li>• Call waiting, call hold, call divert, and call timer</li> <li>• Automatic and manual network selection</li> <li>• Vibrating alert</li> </ul>
Voice features	<ul style="list-style-type: none"> <li>• Integrated handsfree speaker</li> </ul>
Personalise	<ul style="list-style-type: none"> <li>• Graphics, icons, animations, logos</li> <li>• 3 games available . The selection of games depends on the region the phone is sold in (Snake, Bunny Brains, Dice, Butler, Carrom , Soccer league, Cricket cup, Rapid Rolls</li> <li>• Ringing tones: Polyphonic tones</li> <li>• Themes: possibility to download new themes</li> </ul>
Phone features	<ul style="list-style-type: none"> <li>• Phone Features</li> <li>• Alarm clock Calendar</li> </ul>

## Mobile enhancements

**Table 1 Power**

Type	Name
BL-5C	Battery 900 mAh Li-Ion
AC-1	Retractable charger
ACP-12	Travel charger
LCH-12	Mobile charger

**Table 2 Car**

Type	Name
CK-10	Nokia car kit
HF-8	Nokia plug-in car handsfreet
MP-2	Microphone
CR-39	Nokia universal holder

**Table 3 Audio**

Type	Name
HDB-5	Boom Headset
HDE-2	Headset
HS-7	Dual Headset
HDA-9	TTY Adapter

**Table 4 Xpress-on™ covers**

Type	Name
CC 232D	EMEA colors: Gray, Blue, Orange, except APAC, which only have gray and blue.

## ■ Technical specifications

### General specifications

Unit	Dimension (mm)	Weight (g)	Volume (cc)
Transceiver with BL-5C 900mAh Li-Ion battery pack	104x44.7x17.2	85	69

### Battery endurance

#### Nokia measurements of operation times in GSM900/1800

Talk time	
Battery: BL-5C 900mAh	Up to 180 min

Standby time	
Battery: BL-5C 900mAh	Up to 300 min

**Note:** Variation in operation times will occur depending on SIM card, network settings and usage. Talk time is increased by up to 30% if half rate is active and reduced by 5% if enhanced full rate is active.

## Environmental conditions

Environmental condition	Ambient temperature	Notes
Normal operation	-15 °C ... +55 °C	Specifications fulfilled
Reduced performance	-30 ...15 °C and +55°C ... +70 °C	Operational only for short periods
Intermittent or no operation	-40 °C ... -30 °C and +70 °C ... +85°C	Operation not guaranteed but an attempt to operate will not damage the phone
No operation or storage	<-40 °C and >+85 °C	No storage. An attempt to operate may cause permanent damage
Charging allowed	-15 °C ... +55 °C	
Long term storage conditions	0 °C ... +85 °C	
Humidity and water resistance		Relative humidity range is 5 to 95%. Condensed or dripping water may cause intermittent malfunctions. Protection against dripping water has to be implemented in (enclosure) mechanics. Continuous dampness will cause permanent damage to the module.

## Electrical characteristics

**Table 5 Normal and extreme voltages**

Voltage	Voltage (V)	Condition
General conditions		
Nominal voltage	3.90V	a
Lower extreme voltage	3.30V	b
Higher extreme voltage	4.30V	c
HW shutdown voltages		
V <sub>mstr+</sub>	2.1V ± 0,1V	Off to on
V <sub>mstr-</sub>	1.9V ± 0,1V	On to off
SW shutdown voltages		
SW shutdown	3. 1V	In call
SW shutdown	3. 2V	In idle
Min operating voltage		
V <sub>coff+</sub>	3. 1V ± 0,1V	Off to on
V <sub>coff-</sub>	2. 8V ± 0,1V	On to off

Voltage	Voltage (V)	Condition
HW reset demands		
Min	1.0V	d
Max	--	

- a. The nominal voltage is defined as being 15% higher than the lower extreme voltage. TA will test with this nominal voltage at an 85% range (0.85x3.9V <sup>a</sup> 3.3V).
- b. This limit is set to be above SW shutdown limit in TA.
- c. During fast charging of an empty battery, this voltage might exceed this value. Voltages between 4.20 and 4.60 might appear for a short while.
- d. The minimum battery cell voltage required for the reset circuitry to turn on. This is not confirmed by measures at pt.

**Table 6 Current consumption**

Condition	Min	Typical	Max	Unit
Call (MoU)		208		mA
(E)GSM 900		188		
GSM 1800		168		
GSM 1900				
Idle (MoU)		2.72		
Power off	150		250	mA

(This page left intentionally blank.)

## 2 — Parts and layouts

(This page left intentionally blank.)



## Table of Contents

Exploded view.....	2-5
Mechanical parts list.....	2-6
Spare parts overview.....	2-7
SWAP phones.....	2-8
Component parts list.....	2-8
Component layouts.....	2-15

### List of Tables

Table 7 Mechanical parts list.....	2-6
Table 8 SWAP phones for RH-64.....	2-8
Table 9 Component parts list.....	2-8

### List of Figures

Figure 2 Exploded view.....	2-5
Figure 3 Spare parts overview.....	2-7
Figure 4 Component layout, bottom side (1jv_50e).....	2-15
Figure 5 Component layout, top side (1jv_50e).....	2-15

(This page left intentionally blank.)

■ Exploded view

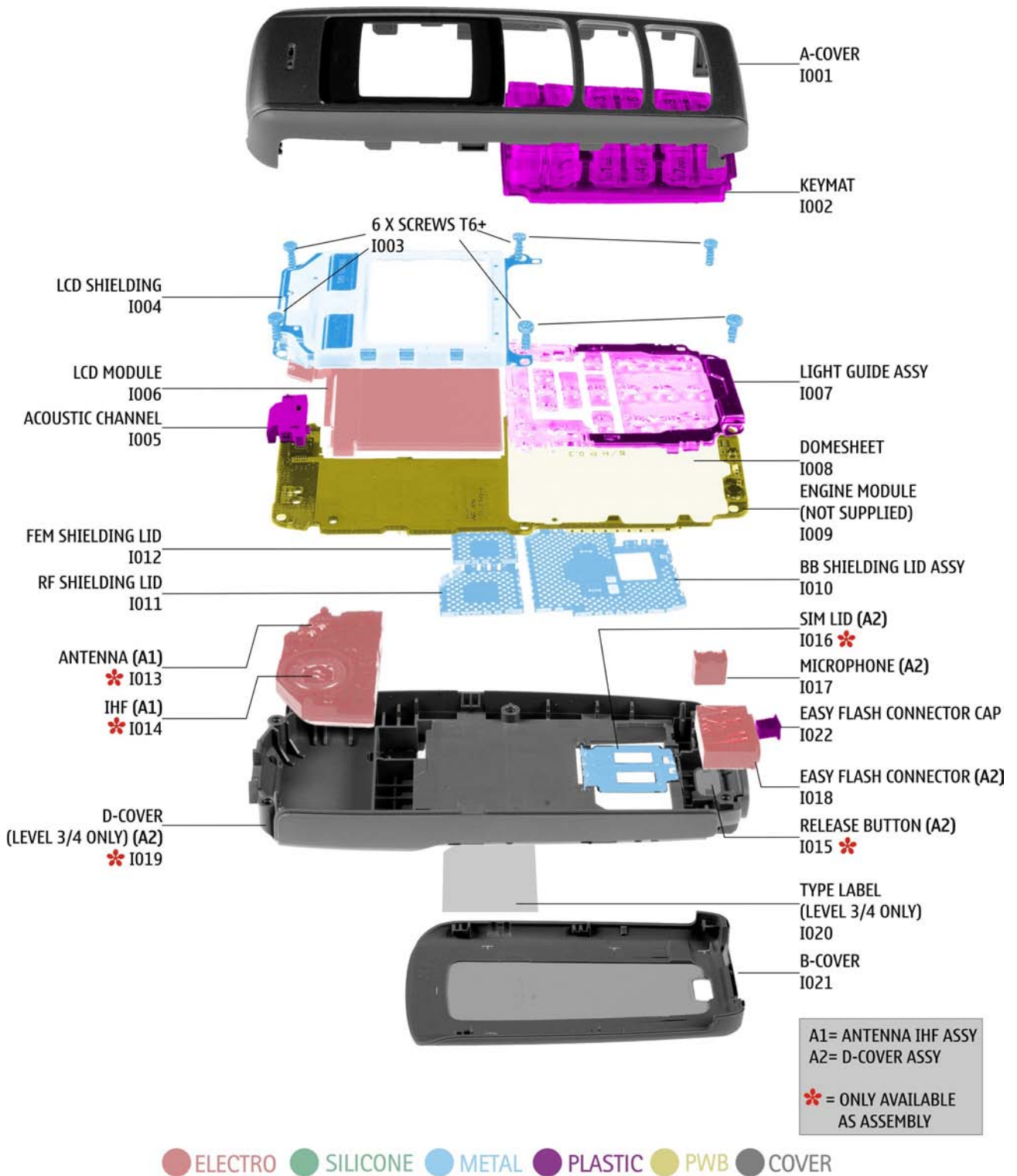

Figure 2 Exploded view

■ **Mechanical parts list**

**Table 7 Mechanical parts list**

ITEM/ CIRCUIT REF.	QTY	PART NAME
* = not available as spare part		
I001	1	A-cover
I002	1	KEYMAT
I003	6	Screws T6+
I004	1	LCD shielding
I005	1	Acoustic channel
I006	1	LCD module
I007	1	Light guide assembly
I008	1	Domesheet
I009	1	Engine module (not supplied)
I010	1	BB shielding lid assembly
I011	1	RF shielding lid
I012	1	FEM shielding lid
I013*	1	Antenna (A1)
I014*	1	IHF (A1)
I015*	1	Release button
I016*	1	SIM lid (A2)
I017	1	Microphone
I018	1	Easy flash connector (A2)
I019*	4	D-cover (A2)
I020	1	Type label
I021	1	B-cover
I022	1	Easy flash connector cap

■ Spare parts overview

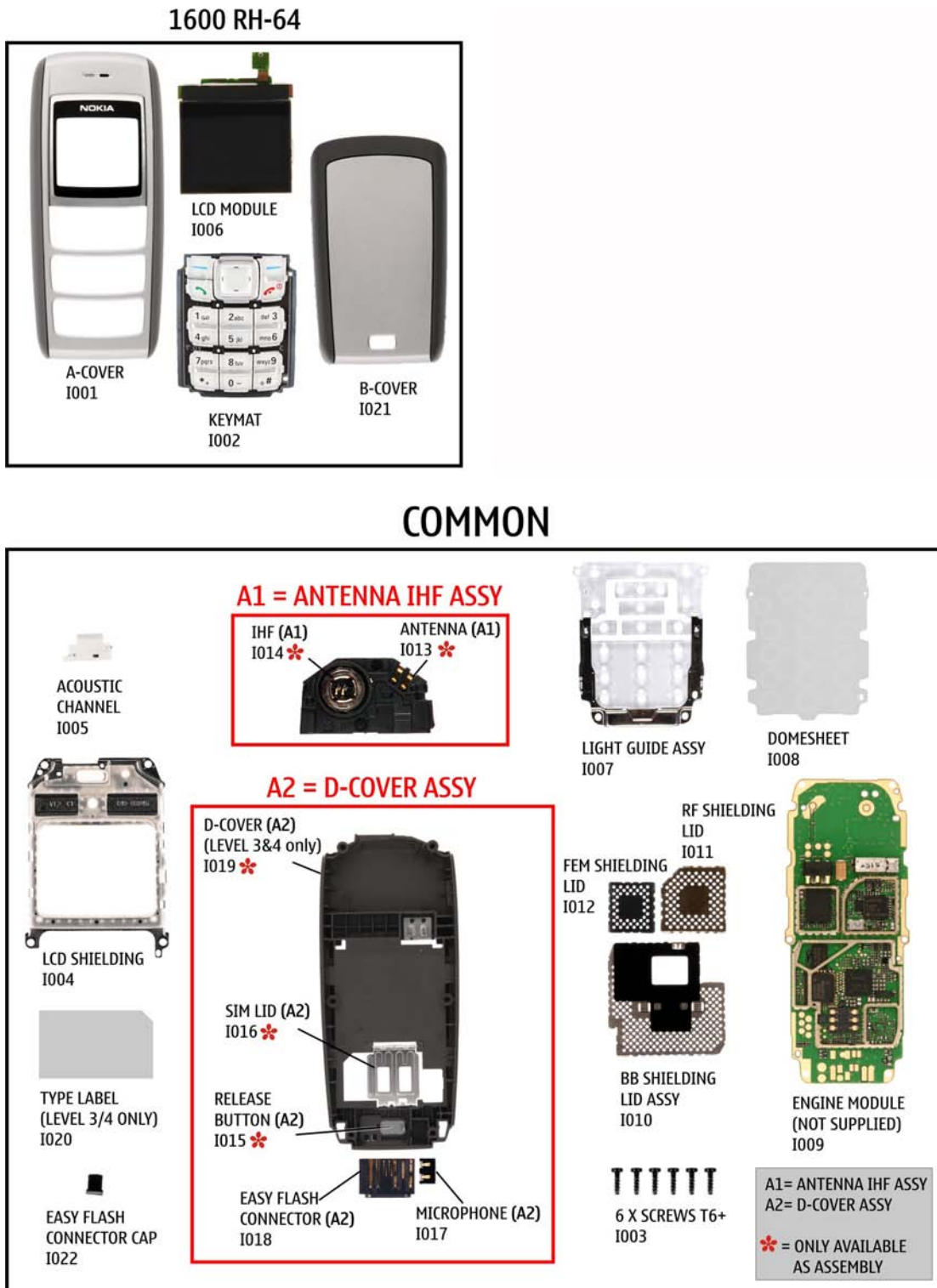

■ **SWAP phones**

**Table 8 SWAP phones for RH-64**

<b>SWAP phones for RH-64</b>
RH-64 SWAP ENGINE EURO-C
RH-64 SWAP ENGINE EURO-C FRANCE
RH-64 EURO-C TURKEY
RH-64 SWAP ENGINE EURO-K
RH-64 SWAP ENGINE UKR
RH-64 SWAP ENGINE EURO-L SOUTH AFRICA
RH-64 SWAP ENGINE APAC-S, Singapore
RH-64 SWAP ENGINE APAC-T, Philippines

■ **Component parts list**

**Table 9 Component parts list**

<b>Item ref</b>	<b>PWB side</b>	<b>X/Y</b>	<b>Object name</b>	<b>Value</b>
A7001	Top	0 5	SHIELD_BB	~
A7002	Top	J 6	SHIELD_RF_ASIC	~
A7003	Top	J 3	SHIELD_FEM	~
B2200	Top	0 7	CRYSTAL 32.768KHZ+-20PPM 12.5PF	32.768KHz
B7600	Top	K 5	CRYSTAL 26MHZ+-10PPM 15.5PF	26MHz
C2000	Top	G 3	Chipcap 5% NPO	27p
C2001	Top	G 2	Chipcap 5% NPO	10p
C2002	Top	G 4	CHIPTCAP 150U M 10V 6X3.2X1.5	150u_10V
C2003	Top	S 5	Chipcap 5% NPO	22p
C2004	Top	R 5	Chipcap 5% NPO	22p
C2005	Top	R 5	Chipcap 5% NPO	22p
C2006	Top	R 5	Chipcap 5% NPO	22p
C2007	Top	S 7	CHIPCAP Y5V 100N Z 25V 0603	100n
C2008	Top	R 4	Chipcap X7R 10% 16V 0402	10n
C2009	Top	R 4	Chipcap X7R 10% 16V 0402	10n
C2010	Top	R 5	Chipcap X7R 10% 16V 0402	10n
C2011	Top	S 3	CHIPCAP X5R 1U K 6V3 0603	1u0
C2012	Top	R 4	Chipcap X7R 10% 16V 0402	10n
C2013	Top	R 3	Chipcap X7R 10% 50V 0402	1n0
C2017	Top	G 5	Chipcap 5% NPO	33p

Item ref	PWB side	X/Y		Object name	Value
C2151	Top	N	7	CHIP ARRAY X5R 2X33N K 10V 0405	2x33n
C2152	Top	S	3	Chipcap 5% NP0	10p
C2153	Bottom	B	6	Chipcap 5% NP0	47p
C2154	Bottom	B	7	Chipcap 5% NP0	47p
C2155	Top	N	6	CHIP ARRAY X5R 2X33N K 10V 0405	2x33n
C2157	Top	O	8	Chipcap 5% NP0	100p
C2159	Top	N	7	CHIPCAP X7R 15N K 16V 0402	15n
C2161	Top	N	8	CHIPCAP X5R 100N M 16V 0402	100n
C2164	Top	N	6	CHIP ARRAY NP0 2X27P K 25V 0405	2x27p
C2165	Top	N	7	CHIP ARRAY X5R 2X1N K 16V 0405	2x1n
C2171	Top	N	8	CHIPCAP X5R 2U2 K 6V3 0603	2u2
C2180	Top	N	7	CHIPCAP X7R 15N K 16V 0402	15n
C2181	Top	M	7	CHIPCAP X5R 100N K 10V 0402	100n
C2182	Top	M	7	CHIPCAP X5R 1U K 6V3 0603	1u0
C2200	Top	O	7	CHIPCAP X5R 1U K 6V3 0603	1u0
C2202	Top	O	7	CHIPCAP X5R 1U K 6V3 0603	1u0
C2203	Top	O	7	CHIPCAP X5R 1U K 6V3 0603	1u0
C2204	Top	P	5	CHIPCAP X5R 1U K 6V3 0603	1u0
C2205	Top	P	5	CHIPCAP X5R 1U K 6V3 0603	1u0
C2208	Top	P	4	CHIPCAP X5R 1U K 6V3 0603	1u0
C2220	Top	M	7	Chipcap X7R 10% 16V 0402	10n
C2222	Top	P	7	CHIPCAP X5R 1U K 6V3 0603	1u0
C2223	Top	O	7	CHIPCAP X5R 1U K 6V3 0603	1u0
C2225	Top	M	6	CHIPCAP X5R 1U K 6V3 0603	1u0
C2226	Top	P	7	CHIPCAP X5R 1U K 6V3 0603	1u0
C2227	Top	M	6	CHIPCAP X5R 1U K 6V3 0603	1u0
C2230	Top	O	7	CHIPCAP X5R 1U K 6V3 0603	1u0
C2233	Top	O	7	CHIPCAP X5R 1U K 6V3 0603	1u0
C2235	Top	M	7	CHIPCAP X5R 1U K 6V3 0603	1u0
C2236	Top	M	5	CHIPCAP X5R 100N K 10V 0402	100n
C2237	Top	M	5	CHIPCAP X5R 100N K 10V 0402	100n
C2239	Top	P	5	CHIPCAP X5R 100N K 10V 0402	100n
C2240	Top	M	6	Chipcap X7R 10% 16V 0402	10n
C2241	Top	M	6	Chipcap X7R 10% 50V 0402	1n0
C2242	Top	M	6	Chipcap X7R 10% 50V 0402	1n0

Item ref	PWB side	X/Y		Object name	Value
C2261	Top	P	6	CHIPCAP X5R 4U7 K 10V 0805	4u7
C2287	Top	M	5	CHIPCAP X5R 100N K 10V 0402	100n
C2330	Top	G	2	Chipcap 5% NP0	33p
C2331	Top	P	5	CHIPCAP X5R 1U K 6V3 0603	1u0
C2332	Top	P	5	CHIPCAP X5R 4U7 K 10V 0805	4u7
C2400	Bottom	U	4	CHIPCAP X5R 1U K 16V 0603	1u0
C2401	Bottom	U	6	CHIPCAP X5R 1U K 6V3 0603	1u0
C2402	Bottom	C	2	CHIPCAP X5R 100N K 10V 0402	100n
C2403	Bottom	C	2	CHIPCAP X5R 100N K 10V 0402	100n
C2405	Top	P	5	Chipcap 5% NP0	47p
C2700	Top	R	4	CHIPCAP X5R 100N K 10V 0402	100n
C2880	Top	O	4	Chipcap X7R 10% 16V 0402	10n
C2881	Top	P	3	CHIPCAP X5R 100N K 10V 0402	100n
C2882	Top	P	3	Chipcap X7R 10% 16V 0402	10n
C2883	Top	O	2	Chipcap X7R 10% 16V 0402	10n
C2884	Top	O	2	CHIPCAP X5R 100N K 10V 0402	100n
C2885	Top	P	3	Chipcap X7R 10% 16V 0402	10n
C2886	Top	P	3	CHIPCAP X5R 100N K 10V 0402	100n
C2887	Top	O	2	Chipcap X7R 10% 16V 0402	10n
C2900	Top	K	7	Chipcap X7R 10% 50V 0402	1n0
C3030	Top	N	2	Chipcap X7R 10% 16V 0402	10n
C3031	Top	N	2	CHIPCAP X5R 100N K 10V 0402	100n
C3032	Top	N	2	CHIPCAP X5R 100N M 16V 0402	100n
C7604	Top	I	6	CHIPCAP NP0 0P5 C 50V 0402	0p5
C7607	Top	I	7	Chipcap +-0.25pF NP0	1p2
C7610	Top	I	8	Chipcap 5% NP0	10p
C7611	Top	I	7	Chipcap 5% NP0	10p
C7612	Top	I	7	Chipcap 5% NP0	10p
C7613	Top	I	7	CHIPCAP X5R 1U K 6V3 0402	1u0
C7614	Top	J	7	Chipcap +-0.25pF NP0	4p7
C7620	Top	K	7	CHIPCAP X5R 2U2 K 6V3 0603	2u2
C7623	Top	J	7	Chipcap 5% NP0	22p
C7624	Top	J	8	CHIPCAP X5R 100N K 10V 0402	100n
C7625	Top	J	6	Chipcap 5% NP0	22p
C7627	Top	J	5	Chipcap 5% NP0	56p



Item ref	PWB side	X/Y		Object name	Value
C7628	Top	J	5	Chipcap 5% NP0	56p
C7630	Top	K	6	Chipcap 5% NP0	22p
C7631	Top	D	3	CHIPCAP NP0 0P5 C 50V 0402	0p5
C7634	Top	I	7	CHIPCAP X5R 100N K 10V 0402	100n
C7635	Top	K	6	CHIPCAP X5R 100N K 10V 0402	100n
C7636	Top	K	6	Chipcap +-0.25pF NP0	1p8
C7637	Top	K	2	Chipcap 5% X7R	1n0
C7638	Top	K	2	Chipcap 5% NP0	33p
C7639	Top	J	7	CHIPCAP NP0 270P J 25V 0402	270p
C7641	Top	J	7	CHIPCAP NP0 270P J 25V 0402	270p
C7643	Top	K	6	CHIPCAP X5R 100N K 10V 0402	100n
C7644	Top	J	7	Chipcap 5% X7R	560p
C7645	Top	I	7	Chipcap 5% X7R	560p
C7655	Top	I	5	Chipcap 5% NP0	10p
C7656	Top	J	5	CHIPCAP X5R 100N K 10V 0402	100n
C7657	Top	K	7	Chipcap 5% NP0	22p
C7658	Top	J	7	Chipcap 5% NP0	22p
C7659	Top	I	6	Chipcap 5% NP0	22p
C7668	Top	I	6	Chipcap 5% NP0	22p
C7669	Top	K	8	CHIPCAP NP0 3N9 J 25V 0805	3n9
C7700	Top	K	3	Chipcap 5% NP0	33p
C7701	Top	K	3	Chipcap 5% NP0	33p
C7702	Top	K	4	Chipcap 5% NP0	33p
C7711	Top	I	2	CHIPCAP X5R 2U2 K 10V 0805	2u2
C7712	Top	I	4	Chipcap 5% NP0	15p
C7713	Top	I	2	Chipcap 5% NP0	27p
C7714	Top	K	3	Chipcap 5% NP0	27p
C7720	Top	K	4	Chipcap 5% NP0	33p
C7725	Top	K	3	Chipcap 5% NP0	120p
C7726	Top	J	2	Chipcap 5% NP0	22p
C7727	Top	K	2	Chipcap 5% NP0	10p
C7728	Top	K	2	CHIPCAP NP0 0P5 C 50V 0402	0p5
D2200	Top	0	5	UEMCLITE V2.2 WD ENA LEADFREE TFBGA120	~
D2800	Top	0	3	UPP2M V2 10X10	~
D3000	Top	M	3	FLASH 2MX16 1.8/1.8V VFBGA44 PBFREE	2Mx16

Item ref	PWB side	X/Y	Object name	Value
F2000	Top	T 7	SM FUSE FF 2A 32V 0402	2.0A
H2400	Bottom	C 3	SM CONN BTB 2X5 F P0.5	~
L2000	Top	T 7	FERR.BEAD 0R03 42R/100MHZ 3A 0805	42R/100MHz
L2001	Top	R 3	CHIP BEAD ARRAY 2X1000R 0405	2x1000R/100MHz
L2002	Top	R 4	CHIP BEAD ARRAY 2X1000R 0405	2x1000R/100MHz
L2170	Top	S 3	FERRITE BEAD 0R5 600R/100MHZ 0603	600R/100MHz
L2180	Top	M 7	FERR.BEAD 220R/100M 2A 0R05 0603	220R/100MHz
L2181	Top	M 7	FERR.BEAD 220R/100M 2A 0R05 0603	220R/100MHz
L2182	Bottom	B 6	CHIP COIL 33N J Q23/800M 0402	33nH
L2183	Bottom	B 6	CHIP COIL 33N J Q23/800M 0402	33nH
L2400	Bottom	U 6	CHOKE 22U M0.33A 1R5 3.3X3.3X1.3	22uH
L7602	Top	I 7	CHIP COIL 10N J Q30/800M 0402	10nH
L7603	Top	I 7	CHIP COIL 10N J Q30/800M 0402	10nH
L7604	Top	I 6	CHIP COIL 2N2+-0N3 Q30/800M 0402	2n2H
L7605	Top	I 6	CHIP COIL 2N2+-0N3 Q30/800M 0402	2n2H
L7607	Top	H 6	CHIP COIL 2N2+-0N3 Q30/800M 0402	2n2H
M2000	Top	G 6	SMD VIBRA MOTOR 1.3V 90MA 9000RPM	~
N2150	Top	M 7	PW AMP TPA2010D1YZF 250KHZ	~
N2160	Top	L 7	TI ANALOG SWITCH TS5A3159DCKR	~
N2161	Top	L 7	TI ANALOG SWITCH TS5A3159DCKR	~
N2400	Bottom	T 6	DC/DC CONV LM3500/ TK65600 USMD8	~
N7600	Top	J 7	HUGIN + PMB3258V1.1 B9C PGVGFN48-4/-6	~
N7700	Top	J 3	FEM RF3282E5.1 4B-TX 2B-RX	~
R2000	Top	G 3	CHIP VARISTOR VWM5.6V VC15.5 0402	5.6V/15V/0.05J
R2001	Top	Q 3	NTC RES 47K J B=4050+-3% 0402	47k
R2002	Top	R 5	Resistor 5% 63mW	100R
R2003	Top	R 5	Resistor 5% 63mW	100R
R2004	Top	R 5	Resistor 5% 63mW	100R
R2005	Top	S 5	Resistor 5% 63mW	100R
R2006	Top	R 5	RES VARISTOR 14/350V 3PF 0402	14/350V
R2007	Top	R 4	CHIP VARISTOR VWM14V VC50V 0402	14V/50V
R2008	Top	S 4	CHIP VARISTOR VWM14V VC50V 0402	14V/50V
R2009	Top	R 4	CHIP VARISTOR VWM14V VC50V 0402	14V/50V
R2010	Top	S 3	Resistor 5% 63mW	100k
R2011	Top	R 4	RES NETWORK 0W06 2X10R J 0404	2x10R

Item ref	PWB side	X/Y	Object name	Value
R2013	Top	R 5	CHIP VARISTOR VWM5.6V VC15.5 0402	5.6V/15V/0.05J
R2020	Top	R 5	ASIP 4XESD **PB-FREE** BGA5	~
R2027	Top	R 5	Resistor 5% 63mW	10k
R2068	Top	S 2	RES NETWORK 0W03 4X22R J 0804	4x22R
R2069	Top	S 2	Resistor 5% 63mW	1k0
R2070	Top	S 2	CHIP VARISTOR VWM5.6V VC15.5 0402	5.6V/15V/0.05J
R2150	Top	N 7	RES NETWORK 0W06 2X1K0 J 0404	2x1k0
R2151	Top	M 7	Resistor 5% 63mW	10R
R2152	Top	N 7	Resistor 5% 63mW	10k
R2153	Top	N 7	RES NETWORK 0W06 2X2K2 J 0404	2x2k2
R2154	Top	N 7	RES NETWORK 0W06 2X2K2 J 0404	2x2k2
R2155	Top	L 6	Resistor 5% 63mW	10R
R2156	Top	O 7	Resistor 5% 63mW	2k2
R2158	Top	N 7	Resistor 5% 63mW	18k
R2159	Top	N 7	Resistor 5% 63mW	18k
R2160	Top	L 6	Resistor 5% 63mW	100k
R2171	Top	N 8	Resistor 5% 63mW	220R
R2200	Top	P 6	CHIPRES 0W25 0R22 J 0805	0R22
R2202	Top	M 7	Resistor 5% 63mW	100k
R2203	Top	M 7	Resistor 5% 63mW	100k
R2204	Top	M 6	Resistor 5% 63mW	100k
R2205	Top	M 6	RES NETWORK 0W06 2X10K J 0404	2x10k
R2206	Top	M 7	Resistor 5% 63mW	100k
R2207	Top	L 4	Resistor 5% 63mW	1k0
R2400	Bottom	U 5	Resistor 5% 63mW	33R
R2406	Top	O 2	Resistor 5% 63mW	220R
R2407	Top	P 2	Resistor 5% 63mW	220R
R2408	Top	P 2	Resistor 5% 63mW	220R
R2409	Bottom	T 4	Resistor 5% 63mW	10k
R2700	Top	P 4	ASIP SIM INTERFACE **LOW CAP**BGA8	~
R2900	Top	K 7	Resistor 5% 63mW	330R
R3030	Top	O 2	Resistor 5% 63mW	4k7
R7605	Top	K 7	Resistor 5% 63mW	22R
R7606	Top	H 7	Chipres 0W06 jumper 0402	0R
R7609	Top	K 6	Resistor 1% 63mW	12k

Item ref	PWB side	X/Y	Object name	Value
R7610	Top	M 5	RES NETWORK 0W06 2X5K6 J 0404	2x5k6
R7611	Top	M 5	RES NETWORK 0W06 2X5K6 J 0404	2x5k6
R7615	Top	H 8	Resistor 5% 63mW	100R
R7616	Top	H 7	Resistor 5% 63mW	100R
R7617	Top	H 7	Resistor 5% 63mW	100R
R7619	Top	J 8	Resistor 5% 63mW	3k3
R7630	Top	K 6	Resistor 5% 63mW	100k
R7631	Top	K 7	Resistor 5% 63mW	18k
R7632	Top	K 6	Resistor 5% 63mW	39R
R7633	Top	K 2	NTC RES 47K J B=4050+-3% 0402	47k
R7635	Top	K 2	Resistor 5% 63mW	1k0
R7663	Top	K 8	Resistor 5% 63mW	4k7
R7700	Top	I 5	Resistor 5% 63mW	1k0
R7701	Top	I 5	Resistor 5% 63mW	1k0
R7703	Top	J 5	Chipres 0W06 jumper 0402	0R
R7704	Top	K 3	Resistor 5% 63mW	1k0
R7705	Top	K 3	Resistor 5% 63mW	1k0
R7706	Top	K 3	Resistor 5% 63mW	1k0
R7707	Top	I 5	Resistor 5% 63mW	1k0
R7709	Top	I 5	Chipres 0W06 jumper 0402	0R
R7711	Top	J 4	RES NETWORK 0W04 1DB ATT 0404	870R/5R77/870R
R7714	Top	J 2	RES NETWORK 0W04 1DB ATT 0404	870R/5R77/870R
R7720	Top	K 4	Resistor 5% 63mW	1k0
R7732	Top	K 2	Resistor 5% 63mW	10k
R7733	Top	K 2	Resistor 5% 63mW	100R
V2000	Top	S 7	ASIP TVS BGA4	~
V2160	Top	L 6	TR PDTC114EE N 50V RB=RBE=10K EM3	~
V2400	Bottom	U 5	LED WHITE 90-335MCD 15MA 0DEG 1608	~
V2401	Bottom	U 3	TR PDTA114EE RB=RBE=10K 50V SC75	~
V7600	Top	K 6	DI CAP 40/15.8PF 1/3V SCD80	~
X2005	Top	G 3	SM LYNX BATT.CONN 3POL 12V 2A H7	~
X2060	Bottom	T 3	MODULE ID COMPONENT 2.8X1.8X0.3	~
X2700	Top	Q 4	SM SIM CONN 6POL P2.54 H1.8	~
Z2400	Top	Q 3	ASIP EMIF10-1K010F2 **PB-FREE**	~
Z7600	Top	H 6	SAW FILT 1842,5+-37.5MHZ 2.0X1.6	1842.5MHz

Item ref	PWB side	X/Y	Object name	Value
Z7602	Top	H 7	SAW FILT 942.5+-17.5MHZ 2.0X1.6	942.5MHZ
Z7603	Top	J 5	SILICON FILT 869.5+-45.5MHZ P-TSLP-7-4	869.5MHZ
Z7604	Top	J 5	SILICON FILT 1810+-100MHZ P-TSLP-7-4	1710-1910MHZ

■ **Component layouts**

**Component layout, bottom side**

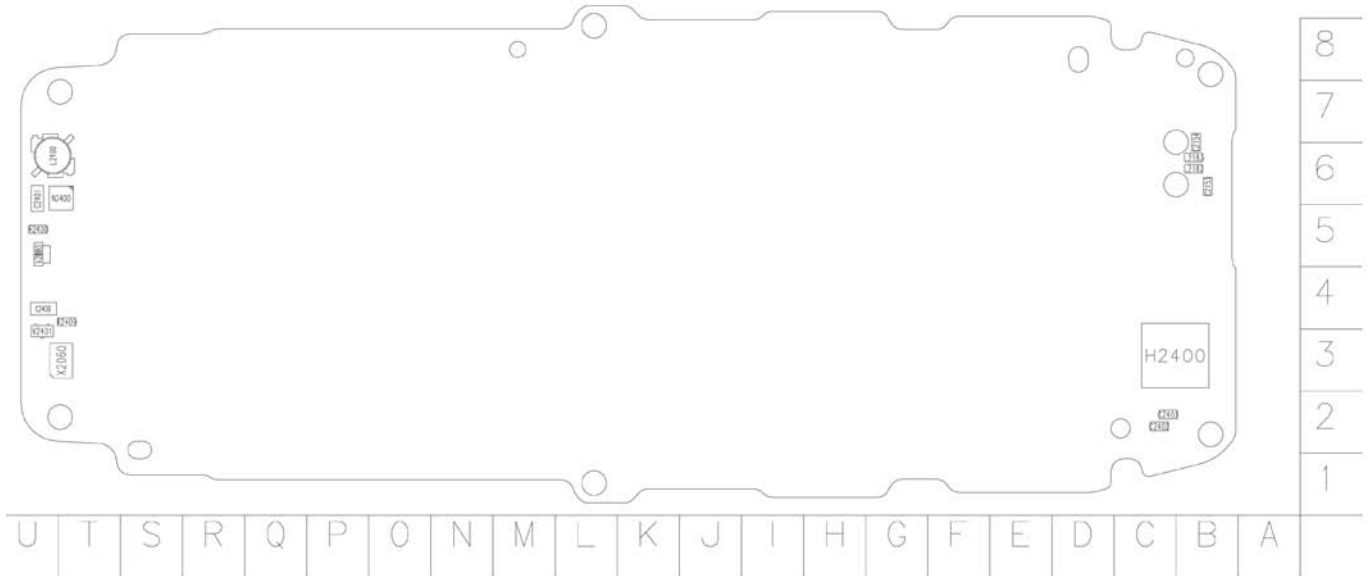

Figure 4 Component layout, bottom side (1jv\_50e)

**Component layout, top side**

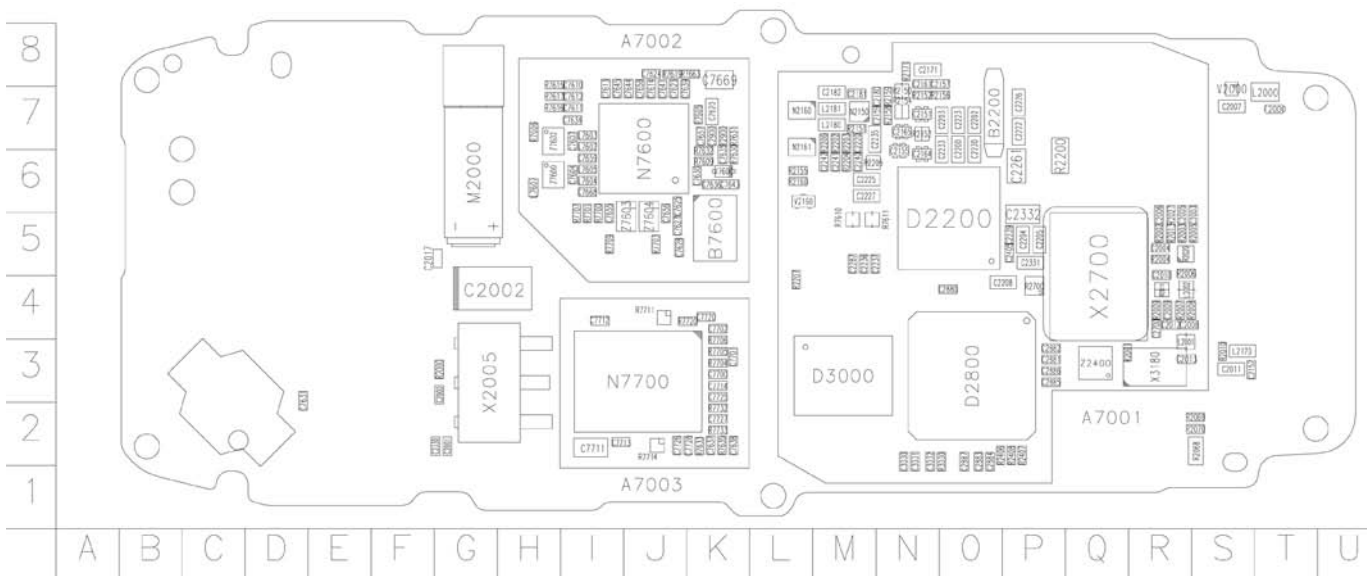

Figure 5 Component layout, top side (1jv\_50e)

(This page left intentionally blank.)

# Nokia Customer Care

## 3 — Phoenix service software

(This page left intentionally blank.)



## Table of Contents

Introduction.....	3-5
Read this first.....	3-5
Service software installation.....	3-5
Phoenix installation steps in brief.....	3-5
Installing Phoenix.....	3-6
Phoenix update installation.....	3-11
Uninstalling Phoenix.....	3-12
Repairing Phoenix installation.....	3-14
Phoenix service software data package overview.....	3-15
Installing Phoenix data package.....	3-16
Uninstalling Phoenix data package.....	3-20
Service software instructions.....	3-21
Configuring users in Phoenix.....	3-21
Managing connections in Phoenix.....	3-22
Installing Flash support files for FPS-8* and FLS-4*.....	3-25
Updating FPS-8 Flash prommer software.....	3-28
Activating FPS-8.....	3-30
Deactivating FPS-8.....	3-32
Updating JBV-1 docking station software.....	3-33

## List of Figures

Figure 6 Dongle not found.....	3-6
Figure 7 Preparing setup.....	3-7
Figure 8 Welcome dialog.....	3-7
Figure 9 Disclaimer text.....	3-8
Figure 10 Destination folder.....	3-8
Figure 11 Installation status 1.....	3-9
Figure 12 Installation status 2.....	3-9
Figure 13 Registering components 1.....	3-10
Figure 14 Restart computer.....	3-10
Figure 15 Registering components 2.....	3-11
Figure 16 Finish installation.....	3-11
Figure 17 Installation interrupted.....	3-12
Figure 18 Remove program.....	3-12
Figure 19 Uninstallation status.....	3-13
Figure 20 Finish uninstallation.....	3-13
Figure 21 Restart computer.....	3-14
Figure 22 Repair program.....	3-15
Figure 23 Finish repair installation.....	3-15
Figure 24 Extracting files.....	3-16
Figure 25 Continue data package installation.....	3-17
Figure 26 Data package setup information.....	3-17
Figure 27 Data package destination folder.....	3-18
Figure 28 Start copying files.....	3-18
Figure 29 Data package installation status.....	3-19
Figure 30 Finish data package installation.....	3-19
Figure 31 Uninstalling Phoenix data package.....	3-20
Figure 32 Finish data package uninstallation.....	3-20
Figure 33 Login.....	3-21

Figure 34 Add information for new user 1.....	3-21
Figure 35 Add information for new user 2.....	3-21
Figure 36 Login, user configured.....	3-22
Figure 37 Phoenix icon.....	3-22
Figure 38 Manage connections.....	3-22
Figure 39 Connections list.....	3-23
Figure 40 Select mode: Manual.....	3-23
Figure 41 FLS virtual port icon.....	3-23
Figure 42 Connections list.....	3-24
Figure 43 Connection information.....	3-24
Figure 44 Scan product.....	3-24
Figure 45 Product support module information.....	3-25
Figure 46 Flash update welcome dialog.....	3-25
Figure 47 Uninstall flash update package.....	3-26
Figure 48 Flash installation interrupted.....	3-26
Figure 49 Continue flash update.....	3-26
Figure 50 Flash destination folder.....	3-27
Figure 51 Flash installation status.....	3-27
Figure 52 Finish flash update.....	3-28
Figure 53 Phoenix icon.....	3-28
Figure 54 FPS-8 maintenance.....	3-28
Figure 55 Prommer SW update.....	3-29
Figure 56 Prommer SW update done.....	3-29
Figure 57 FPS-8 info window.....	3-30
Figure 58 Flash directory window.....	3-30
Figure 59 FPS-8 maintenance.....	3-31
Figure 60 FPS-8 info window.....	3-31
Figure 61 Box activation.....	3-32
Figure 62 Deactivation warning.....	3-32
Figure 63 Extracting JBV-1 update files.....	3-33
Figure 64 JBV-1 update information.....	3-34
Figure 65 JBV-1 update destination folder.....	3-34
Figure 66 Select installation: Full.....	3-35
Figure 67 Select program folder.....	3-35
Figure 68 Finish JBV-1 update installation.....	3-36
Figure 69 Checking JBV-1 SW version.....	3-36
Figure 70 JBV-1 update directory window.....	3-37
Figure 71 JBV-1 SW update done.....	3-37
Figure 72 JBV-1 SW status.....	3-37

## ■ Introduction

### Read this first

The Phoenix software is used to a number of different phones containing different versions of baseband generations.

These instructions are intended as a general guide and are not product specific, where a Phoenix SW version is shown you should use the relevant version for your product and in the screen shots where a type designator is shown you should read the type designator for your product."

## ■ Service software installation

### Phoenix installation steps in brief

Phoenix is the DCT-4 generation service software for reprogramming, testing and tuning the phone.

To install Phoenix, you need to:

- Connect a DK2 Dongle or FLS-4S POS Flash Device
- Install the Phoenix Service SW
- Install the Data Package for Phoenix
- Configure users
- Manage connection settings (depends on the tools you are using)

Phoenix is now ready for FLS-4S Point Of Sales Flash Device use.

If you use FPS-8:

- Update FPS-8 SW
- Activate FPS-8
- Update JBV-1 Docking Station SW (only when needed)

Phoenix is now ready to be used with FPS-8 flash prommer and other tools as well.

The Phoenix Service Software installation contains:

- Service software support for all phone models included in the package
- Flash update package files for FPS-8\* and FLS-4S programming devices
- All needed drivers for:
  - DK2 dongle
  - FLS-4S point of sales flash device
  - USB devices

**Note:** Separate installation packages for flash update files and drivers are also available, but it is not necessary to use them unless updates appear between Phoenix Service SW releases. If separate update packages are used, they should be used after Phoenix and data packages have been installed.

### Supported operating systems

- Windows 2000 and XP.

### Hardware requirements for using Phoenix

- Minimum: Processor 300 MHz, RAM memory 64 MB, disk space 100 MB.
- Recommended for Windows 2000: Processor 700 MHz, RAM memory 256 MB, disk space 150 MB.

## Installing Phoenix

### Before you begin

- Check that a Dongle is attached to the parallel port of your computer.
- Download the installation package (for example, *phoenix\_service\_sw\_a15\_2004\_24\_7\_55.exe*) to your computer (in *C:\TEMP*, for instance).
- Close all other programs.
- Run the application file (for example, *phoenix\_service\_sw\_a15\_2004\_24\_7\_55.exe*) and follow the instructions on the screen.

**Note:** Administrator rights may be required to be able to install Phoenix depending on the operating system.

If uninstalling or rebooting is needed at any point, you will be prompted by the Install Shield program.

### Context

If at any point during installation you get this message, Dongle is not found and installation cannot continue:

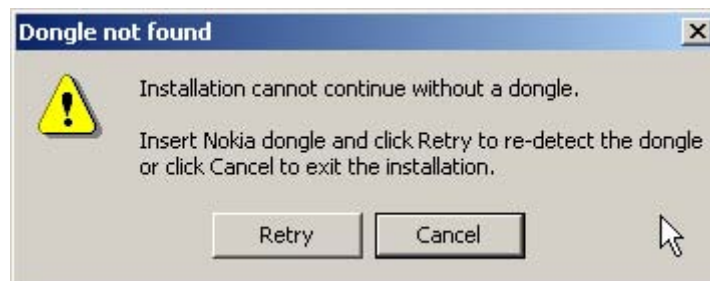

Figure 6 Dongle not found

Possible reasons may be a defective or too old PKD-1 Dongle (a new dongle has a six digit serial number).

Check the COM/parallel ports used first! After correcting the problem the installation can be restarted.

For more detailed information, please refer to Phoenix Help files. Each feature in Phoenix has its own Help function, which can be activated while running the program. Press the F1 key or the Help button to activate a Help file.

## Steps

1. Run the *phoenix\_service\_sw\_a15\_2004\_24\_7\_55.exe* to start installation. Install Shield prepared the setup.

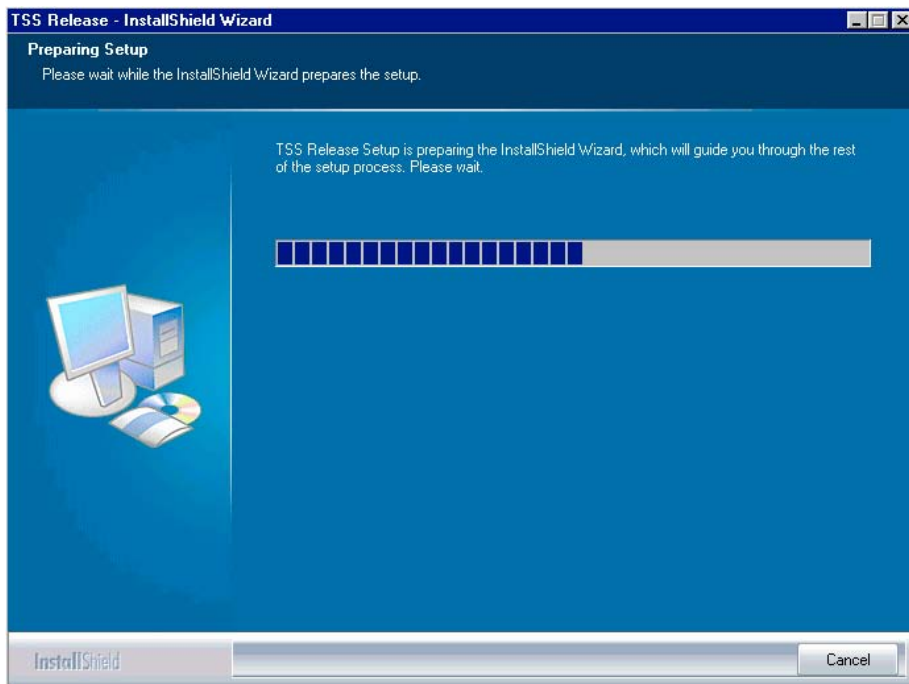

Figure 7 Preparing setup

Install Shield will prepare.

2. Click Next in Welcome dialog to continue.

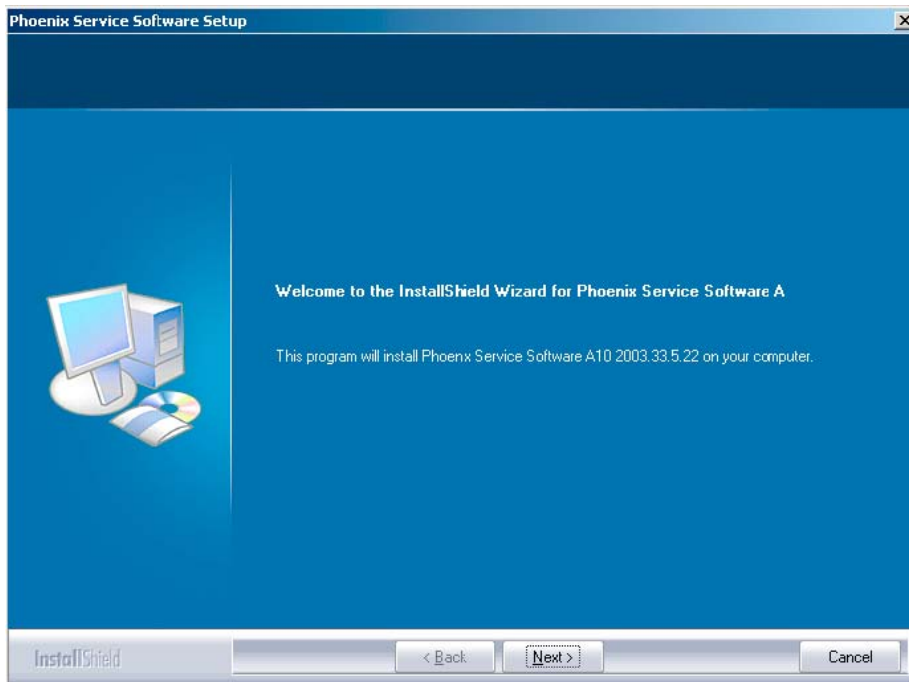

Figure 8 Welcome dialog

3. Read the disclaimer carefully.

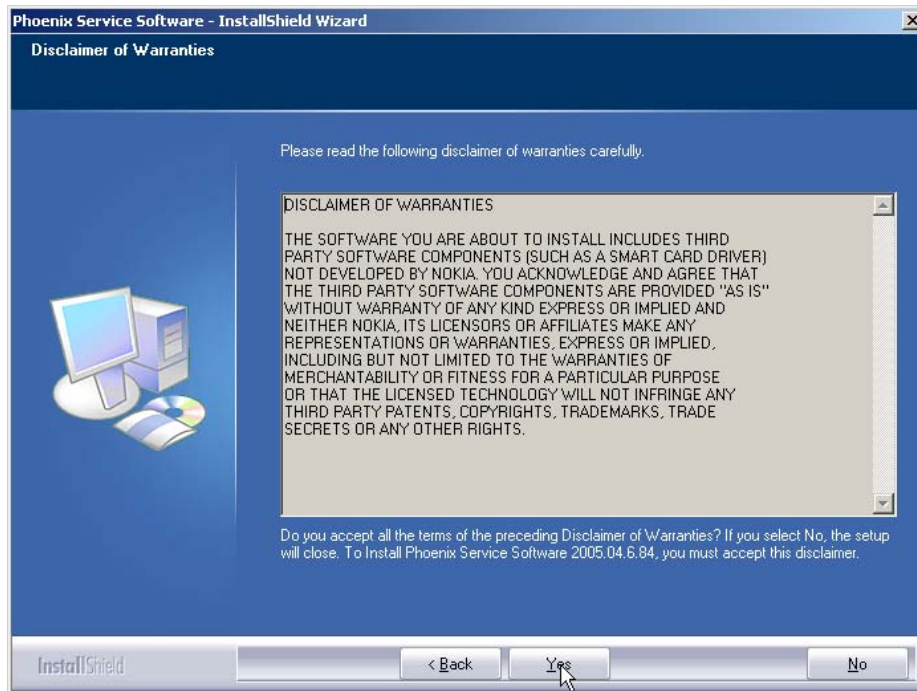

Figure 9 Disclaimer text

4. Choose destination folder. The default folder *C:\Program Files\Nokia\Phoenix* is recommended. Then click Next to continue. You may choose another location by selecting Browse (not recommended).

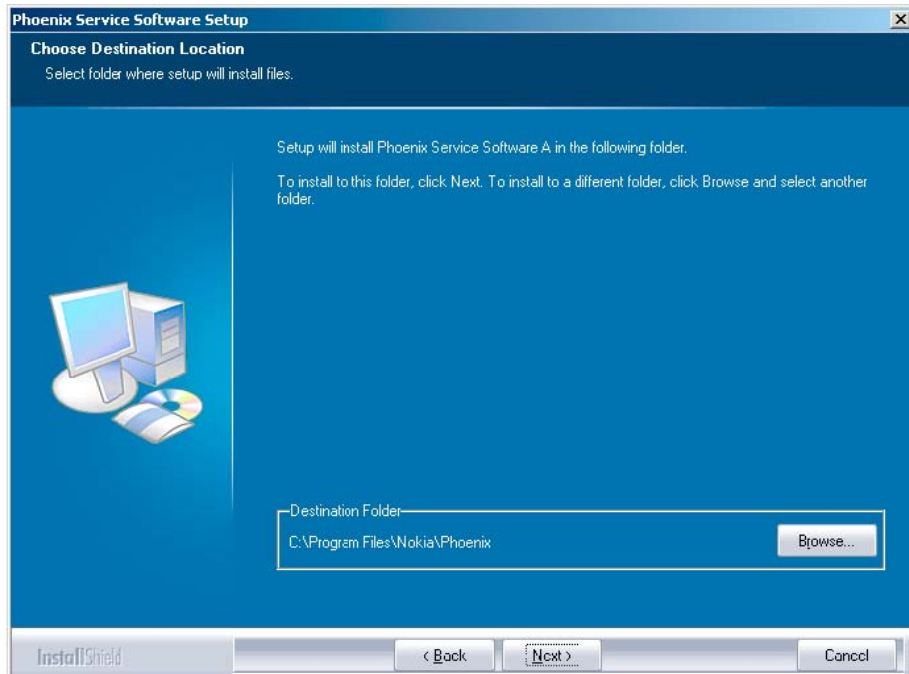

Figure 10 Destination folder

5. Wait for the components to be copied. The progress of the setup is shown in the *Setup Status* window.

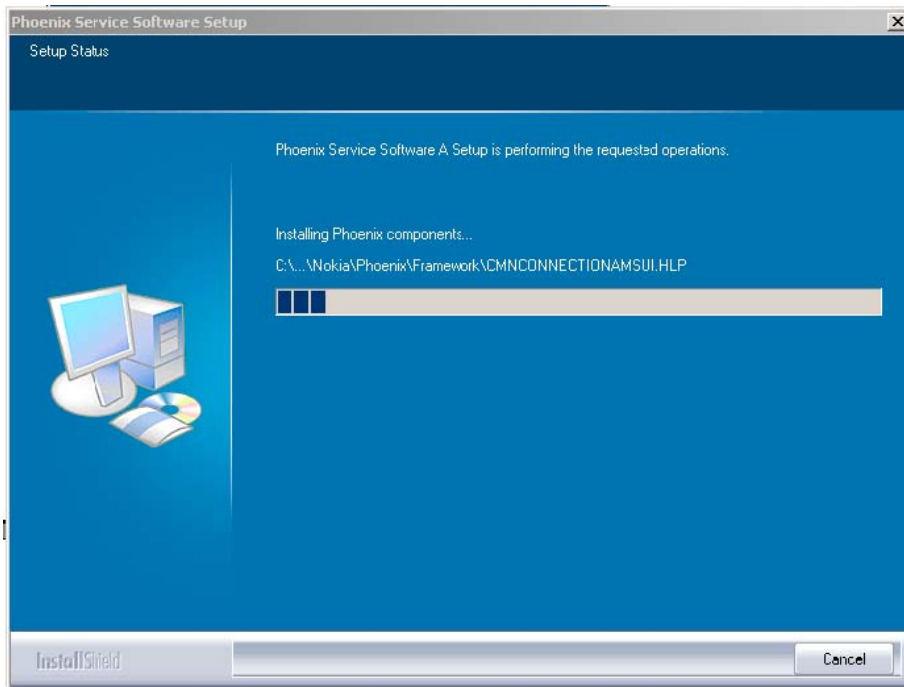

Figure 11 Installation status 1

6. Wait for the drivers to be installed and updated.

The process may take several minutes to complete.

If the operating system does not require rebooting (Windows 2000, XP) the PC components are registered right away.

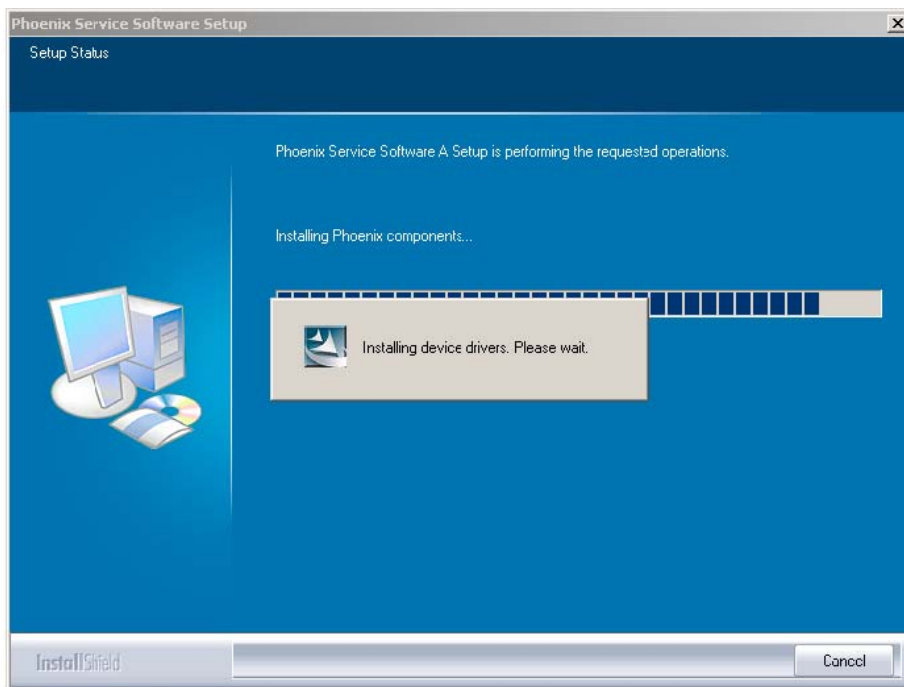

Figure 12 Installation status 2



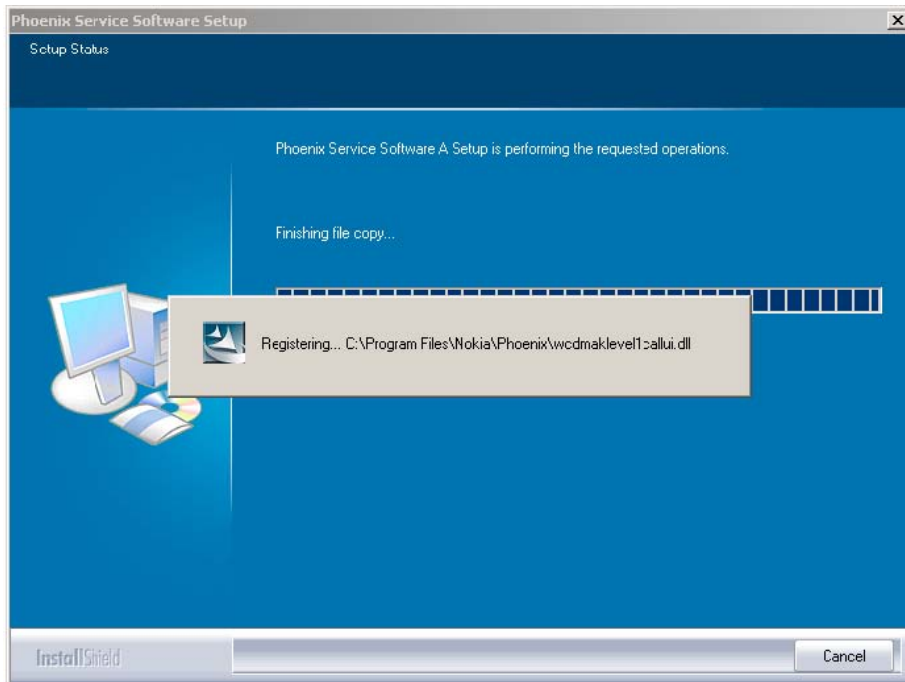

Figure 13 Registering components 1

If the operating system requires restarting your computer (Windows 98, SE, ME) the Install Shield Wizard will tell you about it. Select Yes... to reboot the PC immediately and No... to reboot the PC manually afterwards.

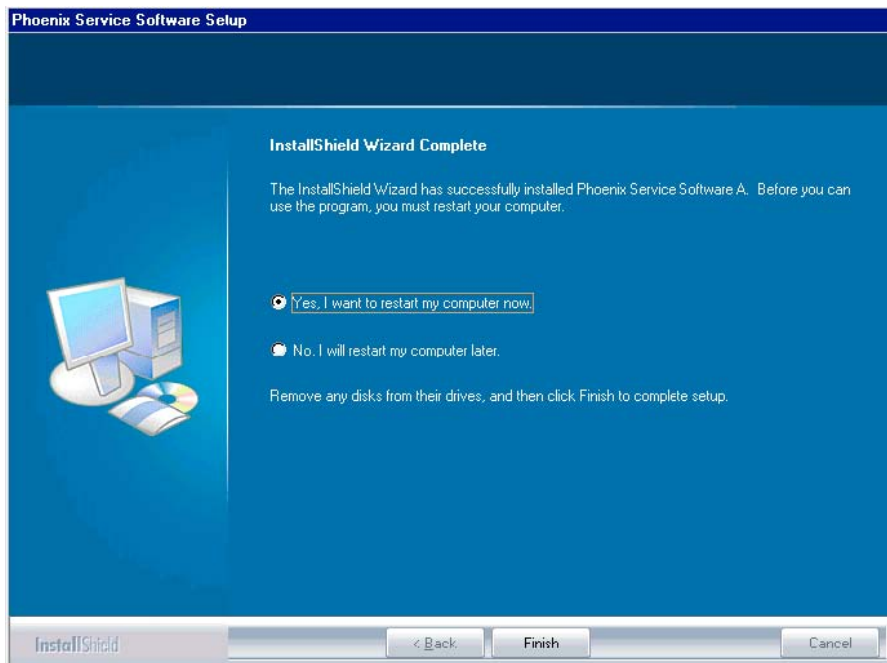

Figure 14 Restart computer

After the reboot, components are registered and Phoenix is ready for use.

**Note:** Phoenix does not work, if components have not been registered.





Figure 15 Registering components 2

7. Click Finish to end installation.

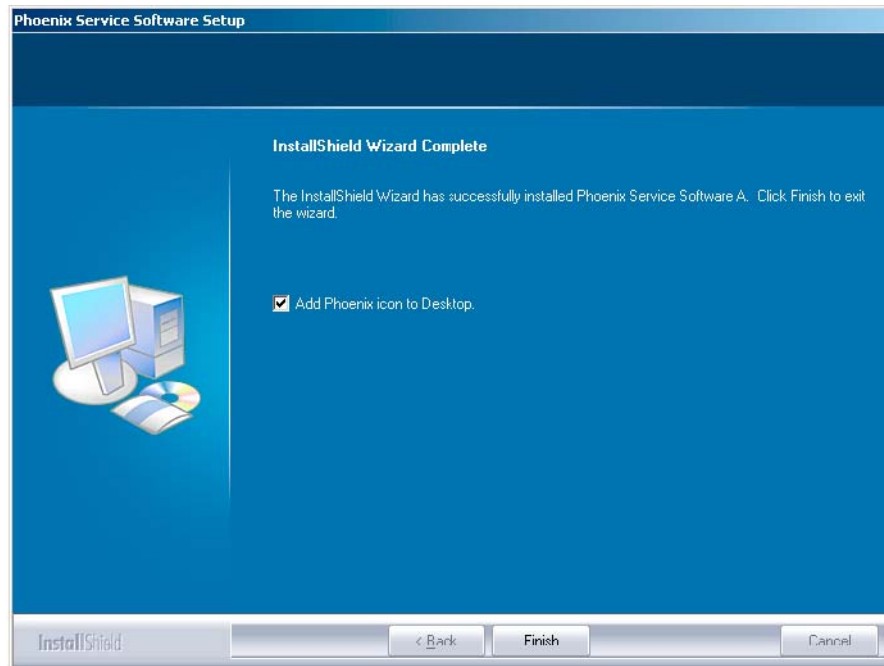

Figure 16 Finish installation

Phoenix is now ready for use.

### Next action

Before using Phoenix Service Software, you must:

- install phone model specific data package for Phoenix, and
- configure users and connections.

FPS-8\* can be used after updating its Flash Update Package files.

### Phoenix update installation

If you already have the Phoenix Service SW installed on your computer, sooner or later there will be need to update it when new versions are released.

Always use the latest available versions of both the Phoenix Service SW and the phone-specific Data Package. Instructions can be found in phone model specific Technical Bulletins and Phone Data Package readme.txt files (shown during installation).

To update the Phoenix Service Software you need to take exactly the same steps as when installing it for the first time:

- Download the installation package to your computer hard disk.
- Close all other programs.
- Run the application file (for example, phoenix\_service\_sw\_a15\_2004\_24\_7\_55.exe).
- New version of Phoenix will be installed.
- Driver versions will be checked and updated.

When you update Phoenix from old to new version (for example, a14\_2004\_16\_4\_47 to a15\_2004\_24\_7\_55), the update will take place automatically without uninstallation.

If you try to update the Phoenix Service Software with the same version that you already have (for example, a15\_2004\_24\_7\_55 to a15\_2004\_24\_7\_55) you are asked if you want to uninstall the version of Phoenix you have on your PC. In this case you can choose between total uninstallation and repair just like when you choose to uninstall Phoenix service software from the Windows Control panel.

If you try to install an older version (for example, downgrade from a15\_2004\_24\_7\_55 to a14\_2004\_16\_4\_47), installation will be interrupted.

Always follow the instructions on the screen.

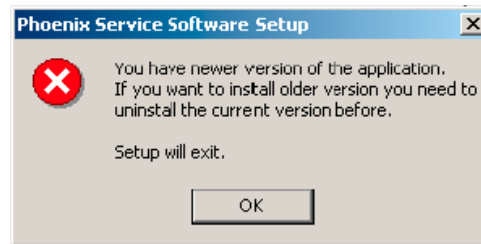

Figure 17 Installation interrupted

## Uninstalling Phoenix

### Context

Uninstallation can be done manually from *Windows Control Panel* → *Add/Remove Programs*.

### Steps

1. Choose *Phoenix Service Software* → *Add/Remove* → *Remove* to uninstall Phoenix.

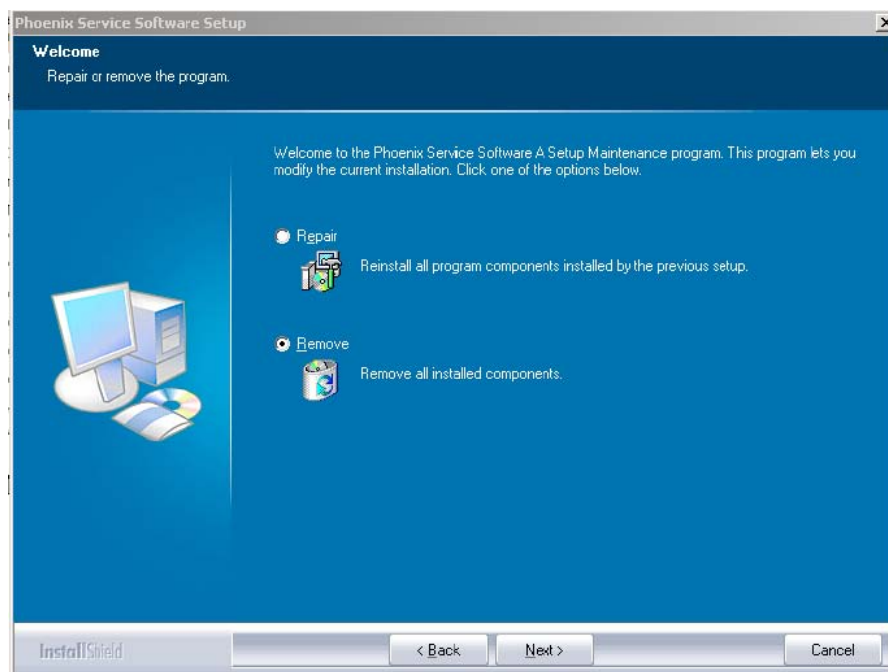

Figure 18 Remove program

The progress of the uninstallation is shown.

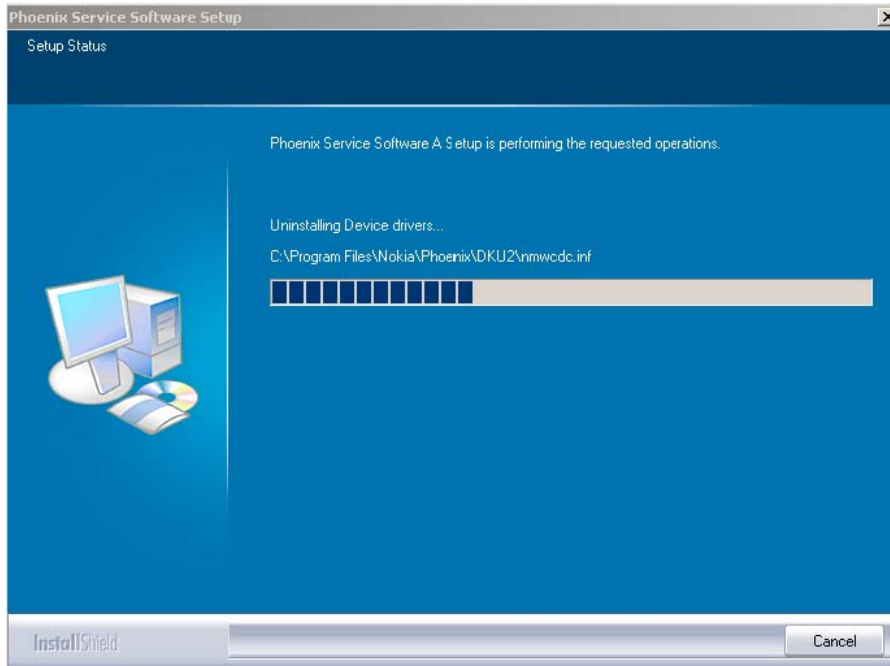

Figure 19 Uninstallation status

2. If the operating system does not require rebooting, click Finish to complete. Else, Install Shield Wizard will tell you about it. Select Yes... to reboot the PC immediately and No... to reboot the PC manually afterwards.

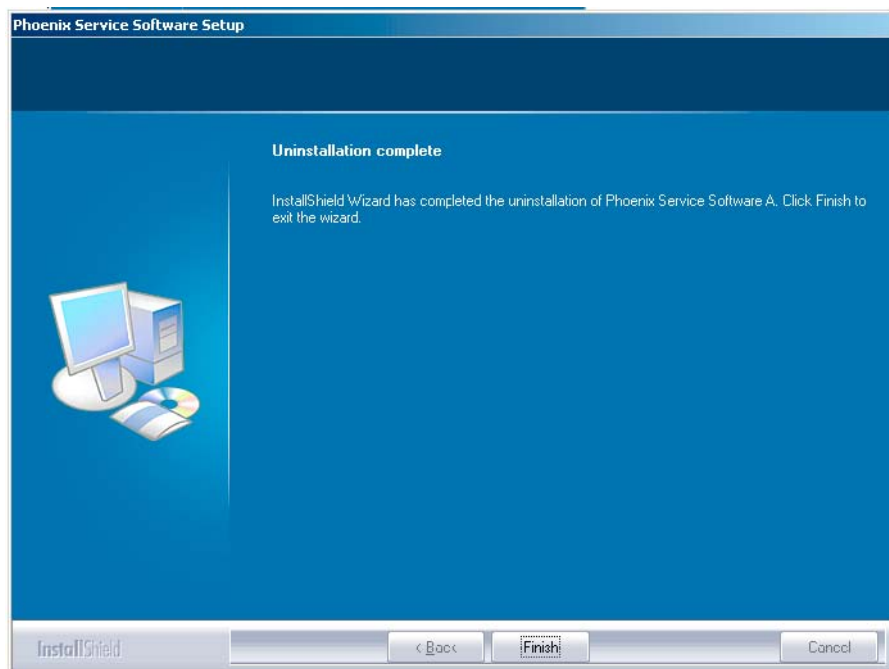

Figure 20 Finish uninstallation

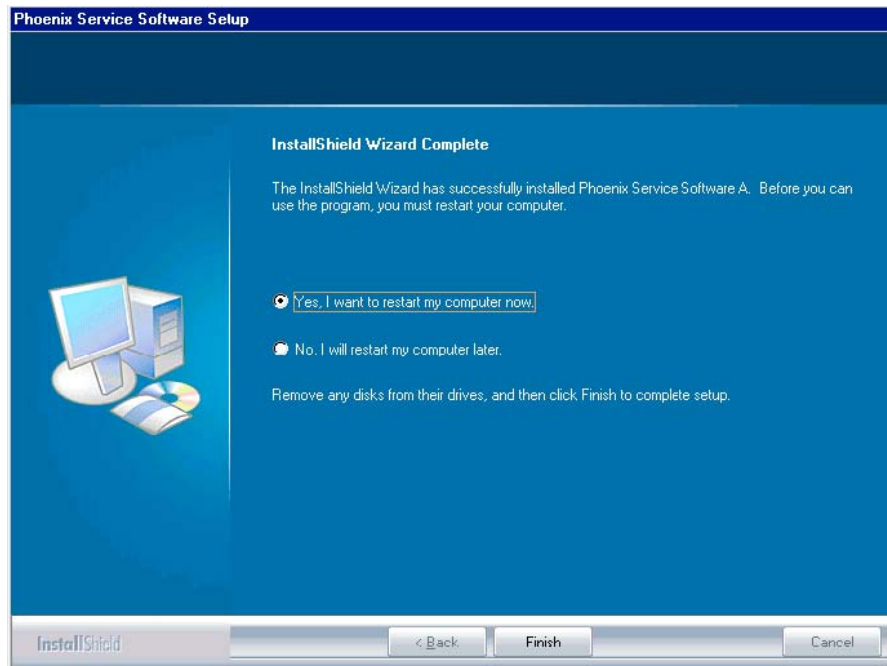

Figure 21 Restart computer

## Repairing Phoenix installation

### Context

If you experience any problems with the service software, or suspect that files have been lost, you can use the repair function before completely reinstalling Phoenix.

**Note:** The original installation package (for example, *phoenix\_service\_sw\_a15\_2004\_24\_7\_55.exe*) must be found on your PC when you run the repair setup.

### Steps

1. Open *Windows Control Panel* → *Add/Remove Programs* .
2. Select *Phoenix Service Software* → *Add/Remove* .
3. In the following view, choose *Repair*.

Phoenix will now reinstall components and register them. The procedure is the same as in the update installation.

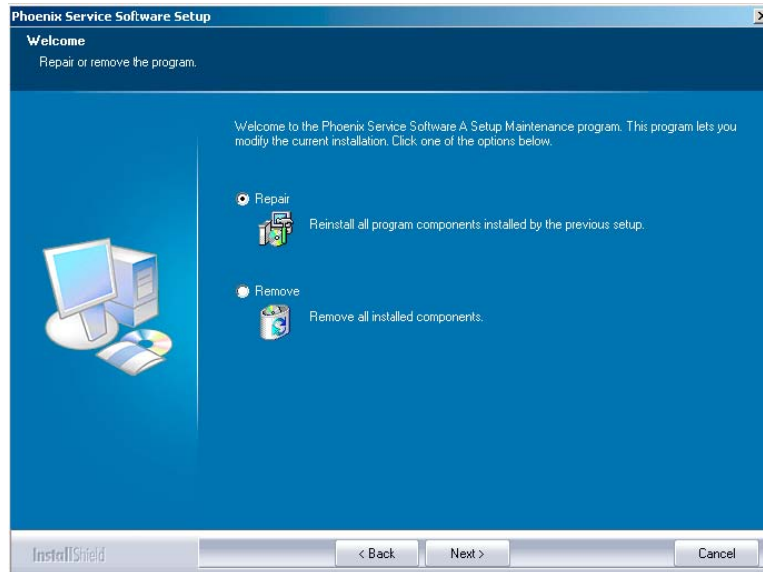

Figure 22 Repair program

4. Click Finish to complete repair.

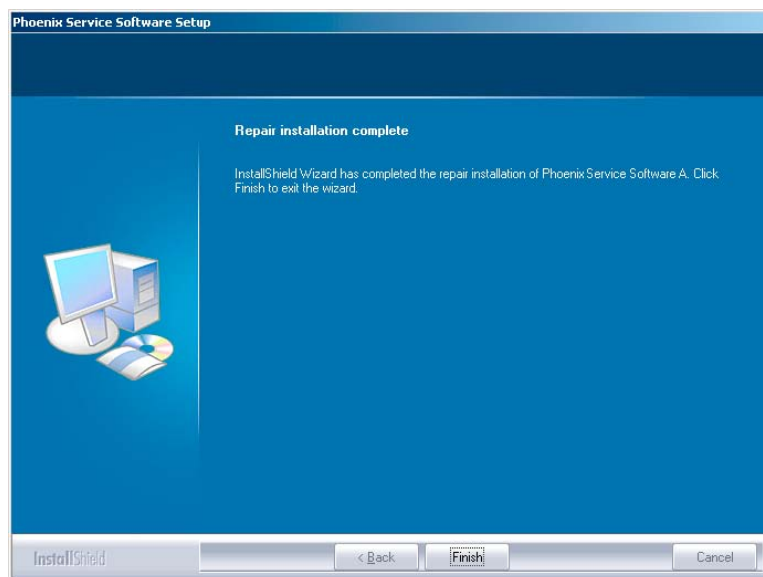

Figure 23 Finish repair installation

## Phoenix service software data package overview

Each product has its own data package (DP). This contains all product-specific data files to make the Phoenix Service Software and tools usable with a certain phone model:

- Product software binary files
- Files for type label printing
- Validation file for the faultlog repair data reporting system
- All product-specific configuration files for Phoenix Service Software components

Data files are stored under C:\Program Files\Nokia\Phoenix (default).

## Installing Phoenix data package

### Before you begin

- 1 Verify that The data package contains all product-specific data to make the Phoenix Service Software and tools usable with a certain phone model.
  - 2 Check that the dongle is attached to the parallel port of your computer.
  - 3 Install Phoenix Service SW.
  - 4 Download the installation package (for example, *RM-51\_dp\_EA\_v\_1\_0.exe*) to your computer (for example, in *C:\TEMP*).
  - 5 Close all other programs.
  - 6 Run the application file (for example, *RM-51\_dp\_EA\_v\_1\_0.exe*) and follow the instructions on the screen.
- If you already have the Phoenix Service SW installed on your computer, you will need to update it when a new version is released.

**Note:** Very often the Phoenix Service SW and the phone-specific data package for Phoenix come in pairs, meaning that a certain version of Phoenix can only be used with a certain version of the data package. Always use the latest available versions of both. Instructions can be found in phone model specific Technical Bulletins and *readme.txt* files of the data packages.

### Steps

1. To start installation, run the application file (for example, *RM-51\_dp\_EA\_v\_1\_0.exe*).
2. Click Next, and wait for the installation files to be extracted.

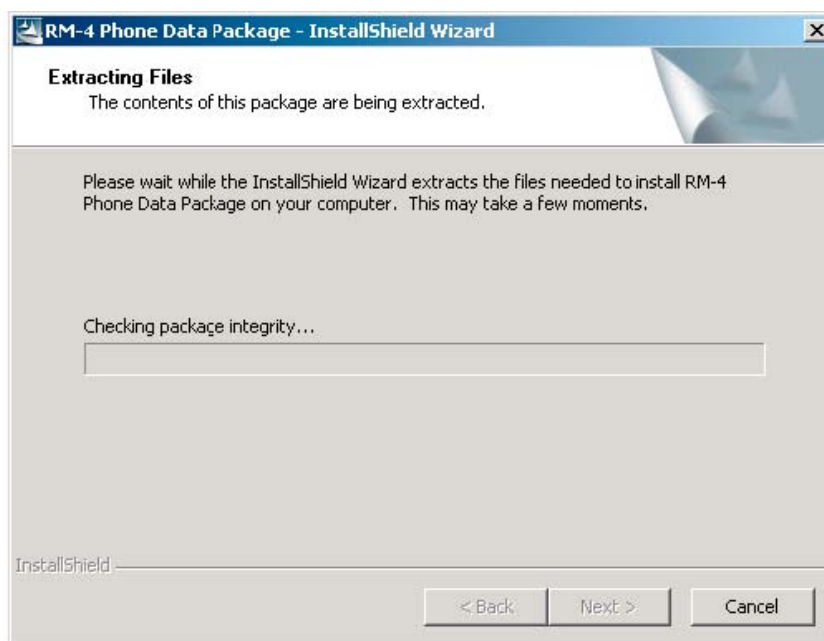

Figure 24 Extracting files

3. Click Next to continue.



Figure 25 Continue data package installation

In this view you can see the contents of the data package. Read the text carefully. There should be information about the Phoenix version required with this data package.

Click Next to continue.

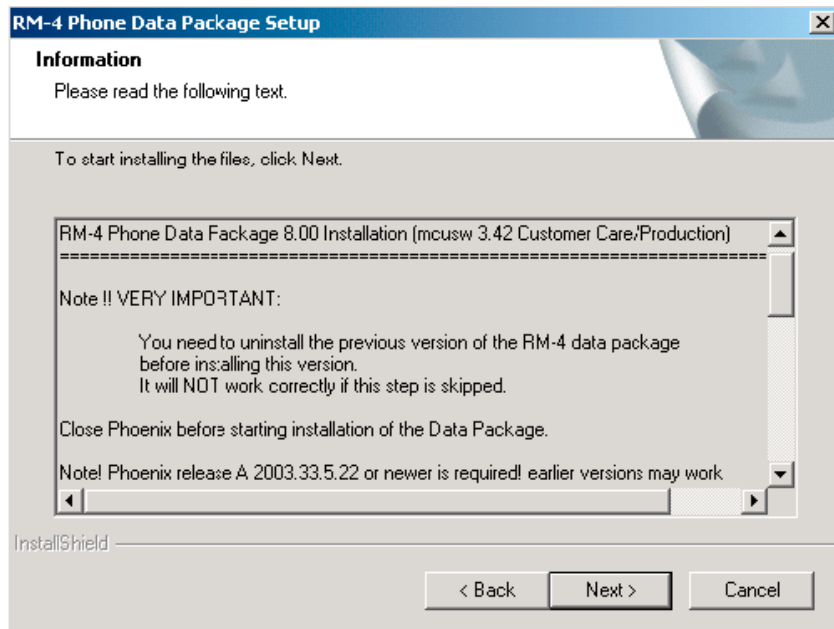

Figure 26 Data package setup information

4. Confirm location and click Next to continue.

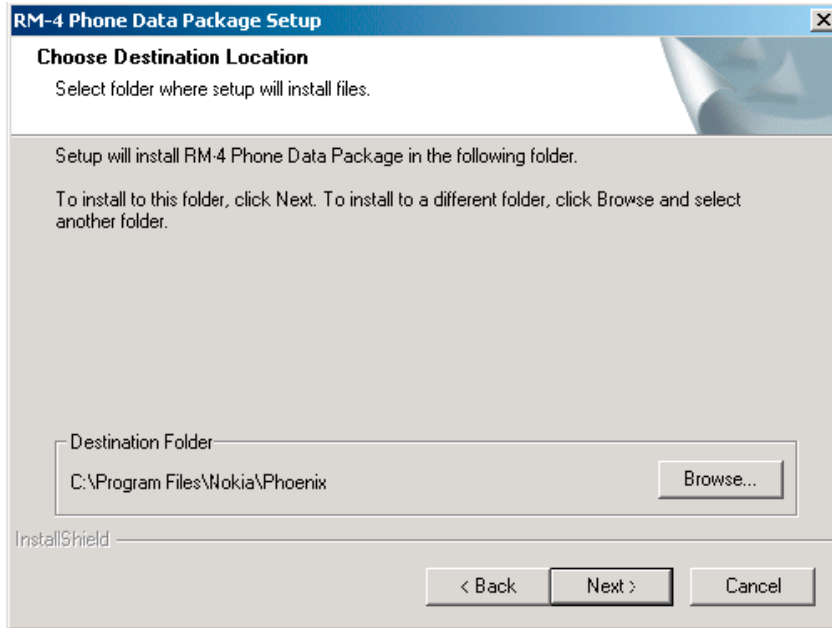

Figure 27 Data package destination folder

The install shield checks where the Phoenix application is installed and the directory is shown. Click Next to continue.

5. Click Next to start copying the files.

Phone model specific files will be installed. Please wait.

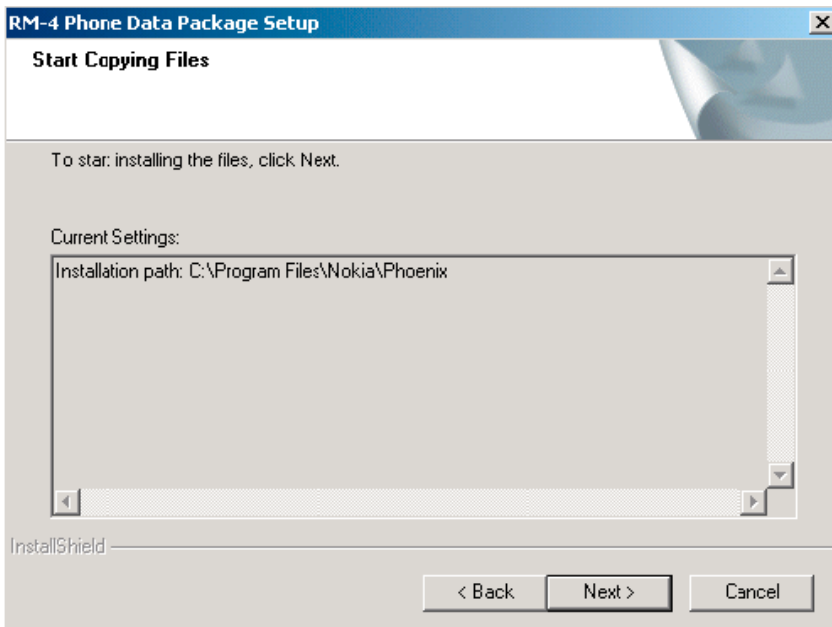

Figure 28 Start copying files



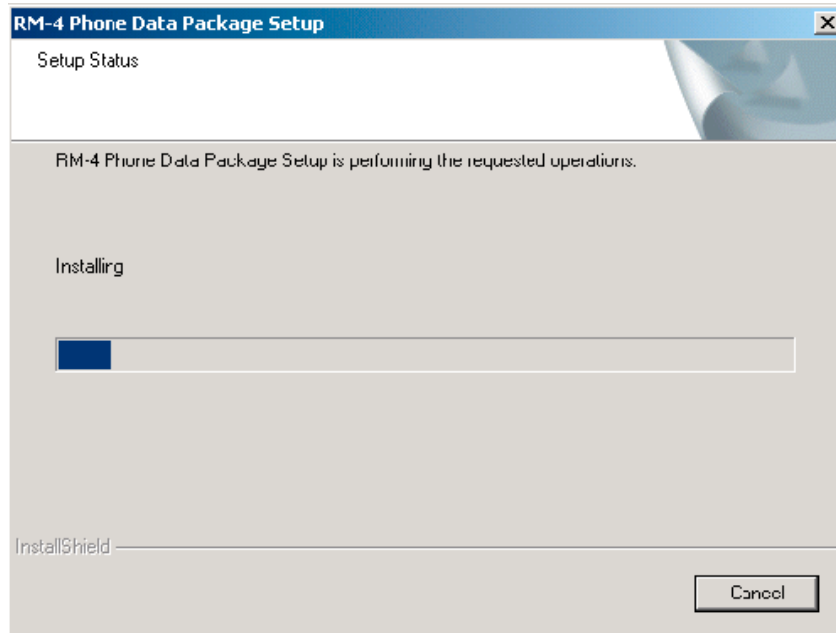

Figure 29 Data package installation status

6. Click Finish to complete the installation.

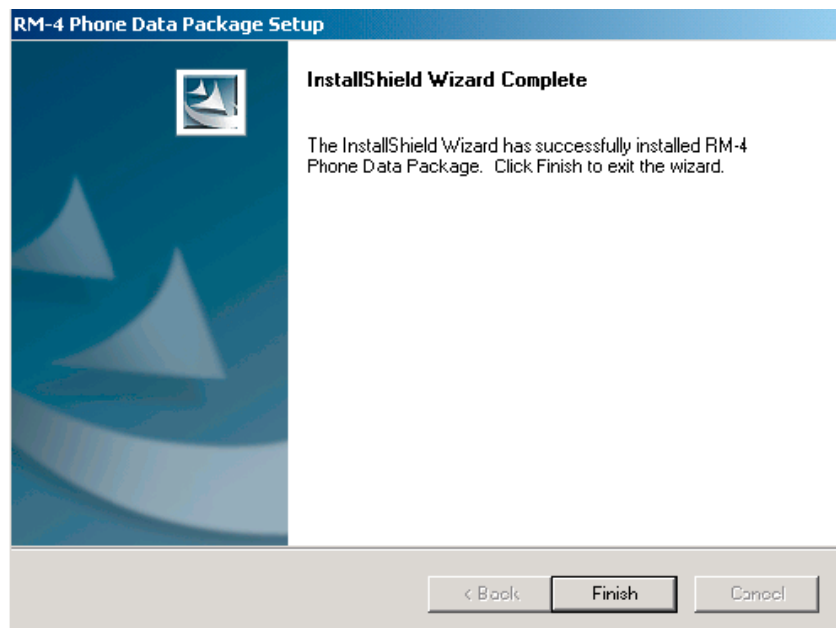

Figure 30 Finish data package installation

You now have all phone model specific files installed in your Phoenix Service SW.

### Next action

Phoenix can be used, for example, for flashing phones and printing type labels. But first you must:

- configure users, and
- manage connections.

FLS-4S can be used right away.

FPS-8\* can be used after updating Flash Update Package files.

## Uninstalling Phoenix data package

### Context

If you try to install the same version of Phoenix data package that you already have, you are asked if you want to uninstall the version you have on your PC. Older versions of data packages don't need to be uninstalled unless instructions to do so are given in the *readme.txt* file of the data package and bulletins concerning the release. Please read all related documents carefully.

### Steps

1. Click OK to uninstall, Cancel if you don't want to uninstall.

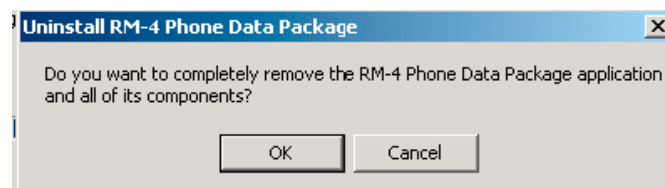

Figure 31 Uninstalling Phoenix data package

2. Once the previously installed data package is uninstalled, click Finish.

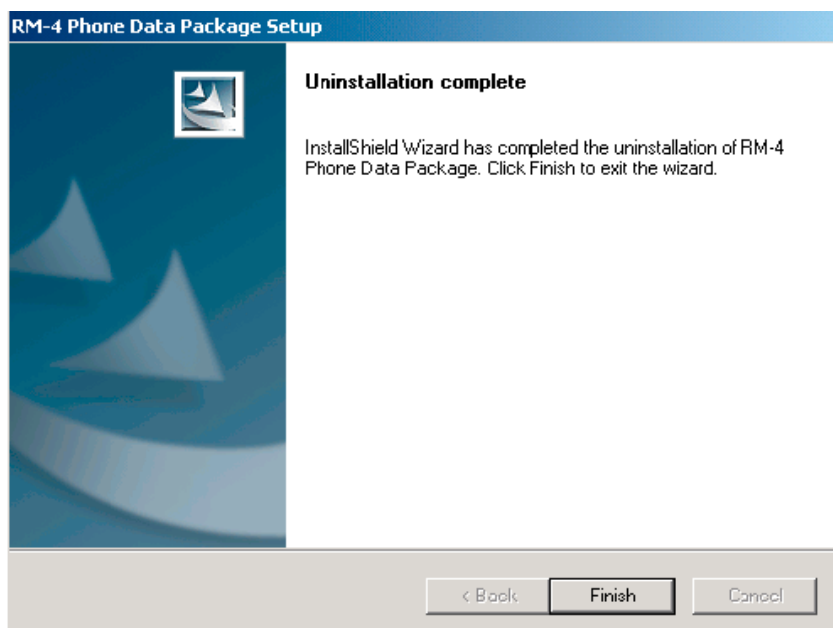

Figure 32 Finish data package uninstallation

### Alternative steps

- Uninstallation can also be done manually from *Windows Control Panel* → *Add/Remove Programs* → *xx-xx (\* Phone Data Package)*. (\*= type designator of the phone)

### Next action

Run the installation package again to continue installation from the beginning.

## ■ Service software instructions

### Configuring users in Phoenix

#### Steps

1. Start Phoenix Service SW and log in.

If your user ID is already configured, choose it from the dropdown list and click OK. To add a new user or edit existing ones click Maintain.

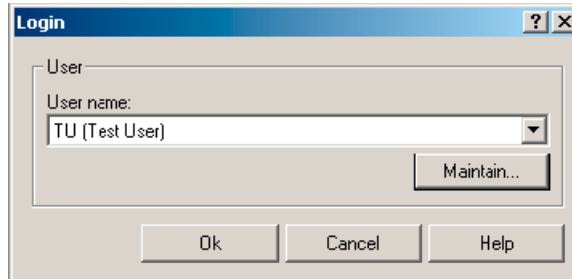

Figure 33 Login

2. Choose New to add information for a new user.

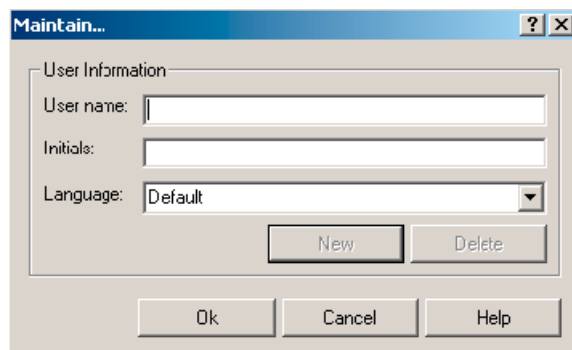

Figure 34 Add information for new user 1

3. Type in your name and initials and click OK.

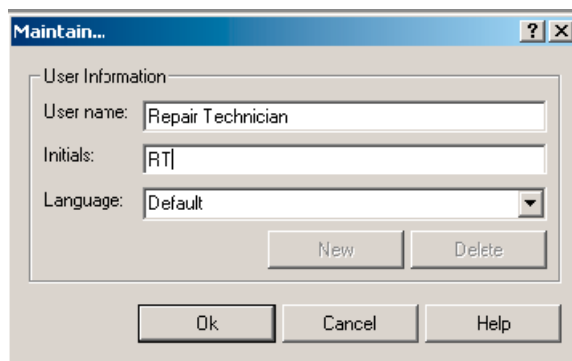

Figure 35 Add information for new user 2

A new user is now created.

4. Click OK.

You are now able to login with this user name.

5. Click OK.

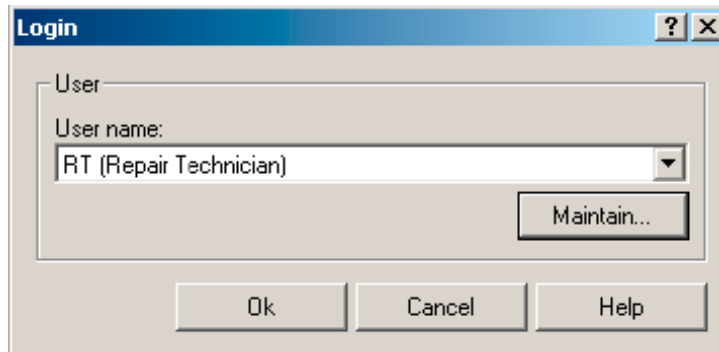

Figure 36 Login, user configured

## Managing connections in Phoenix

### Steps

1. Start *Phoenix Service SW* and log in.



Figure 37 Phoenix icon

2. Choose *File* → *Manage Connections*.

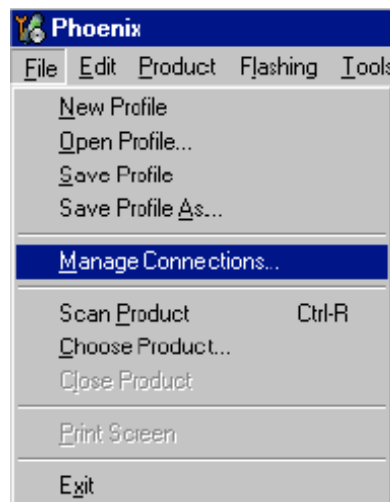

Figure 38 Manage connections

Existing connections can be selected, edited, deleted, and new ones created by using this dialog.

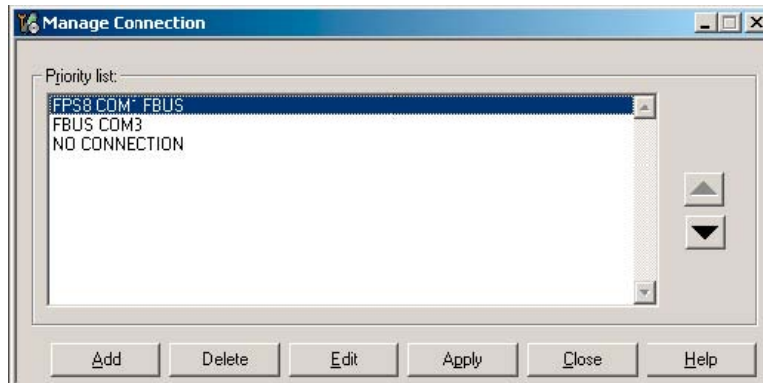

Figure 39 Connections list

3. Click Add to add a new connection, and select if you want to create it manually or by using the Connection Wizard.

In the following dialogs you will be asked to select settings for the connection. If you use the Wizard, connect the tools and a phone to your PC and the wizard will automatically try to configure the correct connection.

4. Select Manual mode, and click Next to continue.

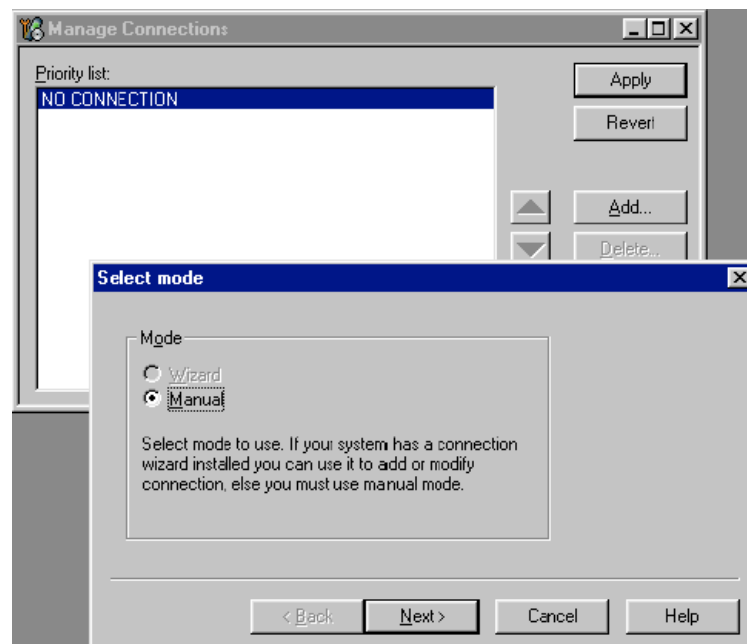

Figure 40 Select mode: Manual

- i For FLS-4S POS Flash Device, choose the following connection settings:

- Media: FBUS
- COM Port: Virtual COM Port used by FLS-4

**Note:** ALWAYS check this. Go to *Windows* → *Control Panel* → *FLS Virtual Port* → *Configuration* .



Figure 41 FLS virtual port icon

- ii For FPS-8 Flash Prommer, choose the following connection settings:
    - Media: FPS-8
    - Port Num: COM Port where FPS-8 is connected
    - COMBOX\_DEF\_MEDIA: FBUS
5. Click Finish to complete the configuration.
6. Activate the connection you want to use by clicking it, use up/down arrows to move it on top of the list, and click Apply.

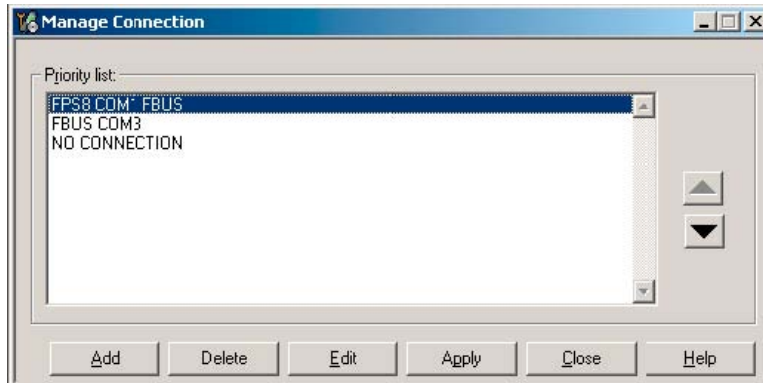

Figure 42 Connections list

The connection is now selected and can be used after closing the *Manage Connections* window. Selected connection will be shown on the right hand bottom corner of the screen.



Figure 43 Connection information

7. To use the selected connection, connect the phone to Phoenix with correct service tools, make sure that it is switched on and select Scan Product.

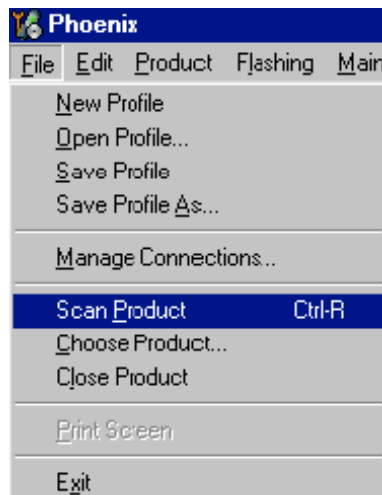

Figure 44 Scan product

When a product is found, Phoenix will load product support. Name of the loaded product support module and its version information will be shown on the bottom of the screen.

V 05.57 , 15-08-02 , NHM-7 , (c) NMP.

Figure 45 Product support module information

## Installing Flash support files for FPS-8\* and FLS-4\*

### Before you begin

**Note:** This is a separate installation package.

- Install Phoenix Service SW.
- Install phone model specific data package for Phoenix.
- The flash support files are delivered in the same installation package with Phoenix data packages or newer Phoenix packages since September 2003.
- Normally it is enough to install Phoenix and the phone-specific data package because the Phoenix installation always includes the latest flash update package files for FLS-4S/FPS-8\*.
- A separate installation package for flash support files is available, and the files can be updated according to this instruction if updates appear between Phoenix/data package releases.

### Context

If you are not using a separate installation package, you can skip this section and continue with [FPS-8 Flash prommer SW update \(Page 3–28\)](#) after installing a new phone data package.

### Steps

1. Start by double clicking *flash\_update\_03\_13\_001.exe* to begin installation.

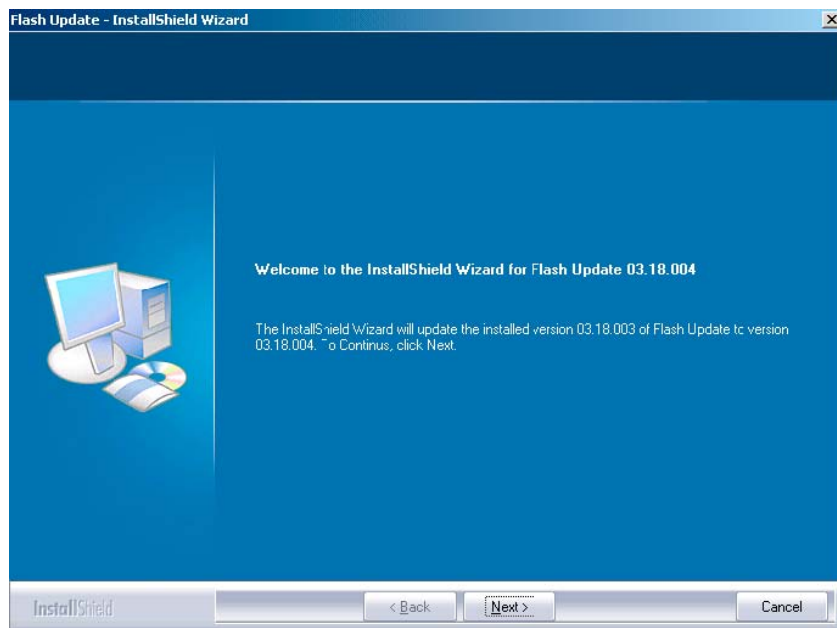

Figure 46 Flash update welcome dialog

2. If the same version of Flash Update package already exists, and you want to reinstall it, the previous package is first uninstalled. Run the installation again.

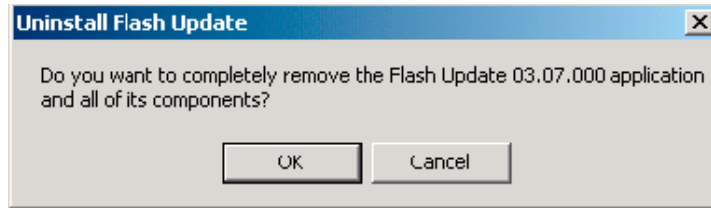

Figure 47 Uninstall flash update package

If you try to downgrade the existing version to older ones, the setup will be aborted. If you really want to downgrade, uninstall newer files manually from Control Panel and then rerun the installation again.



Figure 48 Flash installation interrupted

If an older version exists on your PC and it needs to be updated, click Next to continue installation.

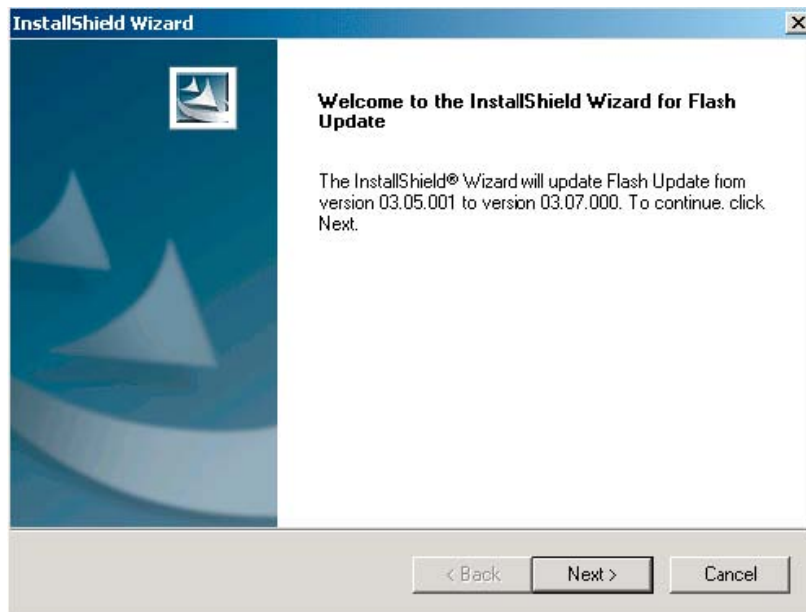

Figure 49 Continue flash update



3. It is highly recommended to install the files to the default destination folder *C:\Program Files\Nokia\Phoenix\Phoenix*. Click Next to continue.

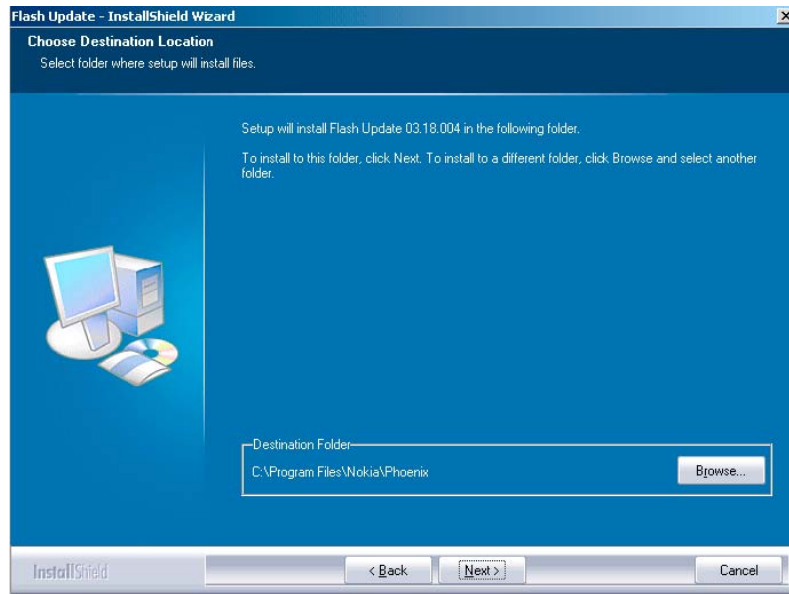

Figure 50 Flash destination folder

When installing the flash update files for the first time you may choose another location by selecting Browse. However, this is not recommended.

Installation will continue.

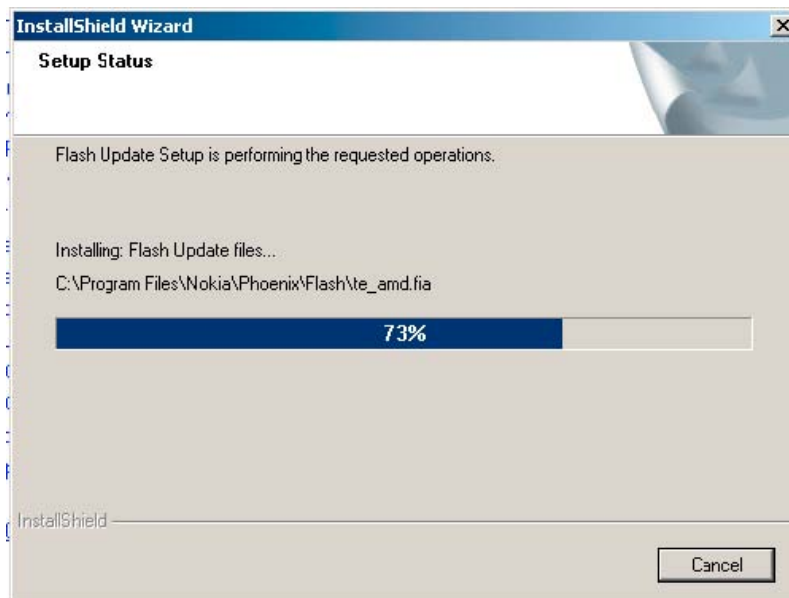

Figure 51 Flash installation status

4. Choose Finish to complete the installation procedure.

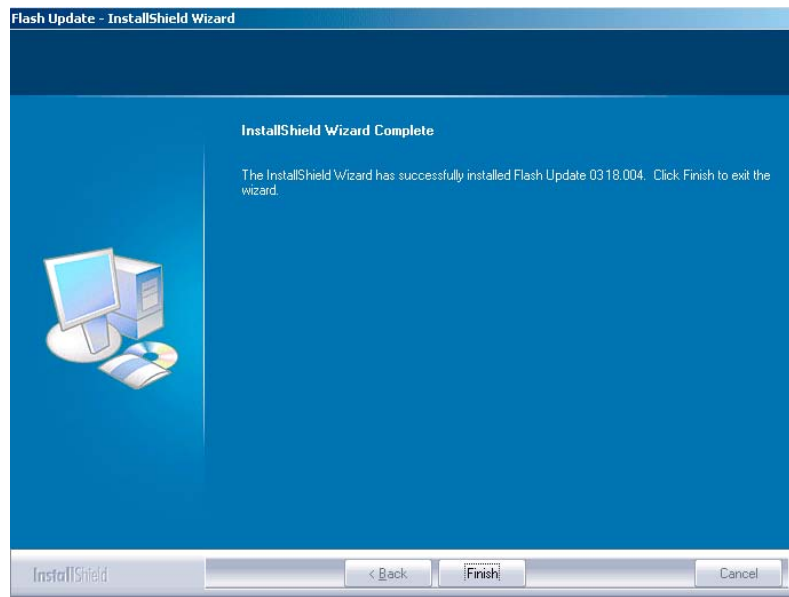

Figure 52 Finish flash update

### Next action

FLS-4 can be used right after the Flash Update Package is installed.

FPS-8\* flash prommer must be updated using Phoenix!

### Updating FPS-8 Flash prommer software

#### Steps

1. Start *Phoenix Service Software* and log in, manage connection correctly for the FPS-8\* flash prommer.



Figure 53 Phoenix icon

2. Choose *Flashing* → *FPS-8 Maintenance*.

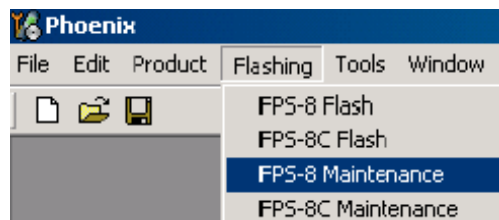

Figure 54 FPS-8 maintenance

**Note:** Screen shots may be different depending on the Phoenix version used and the connected components.

3. When the new FPS-8 flash update package is installed to computer you will be asked to update the files to your FPS-8 Prommer. Select Yes to update files.

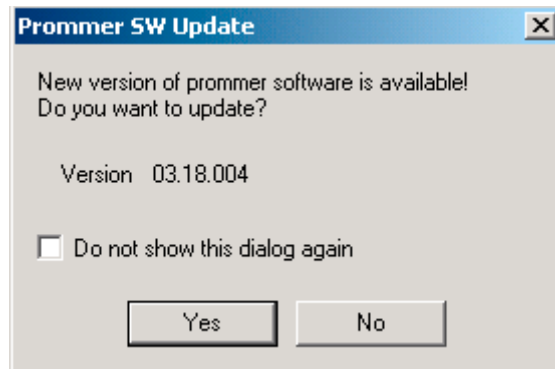

Figure 55 Prommer SW update

4. Wait until you are notified that update has been successful; the procedure will take a couple of minutes. Click OK to close the *FPS-8 Maintenance* window.

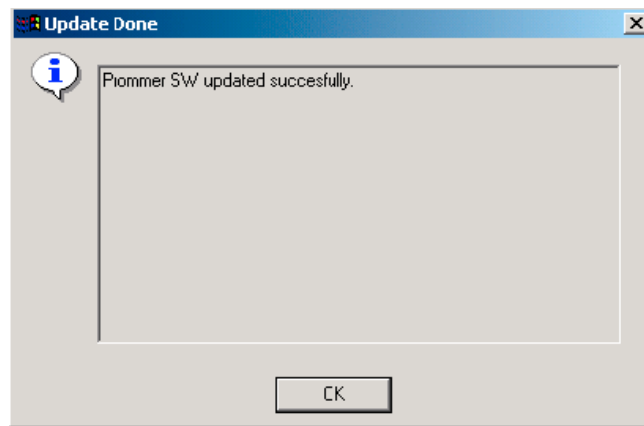

Figure 56 Prommer SW update done

View after successful prommer software update:

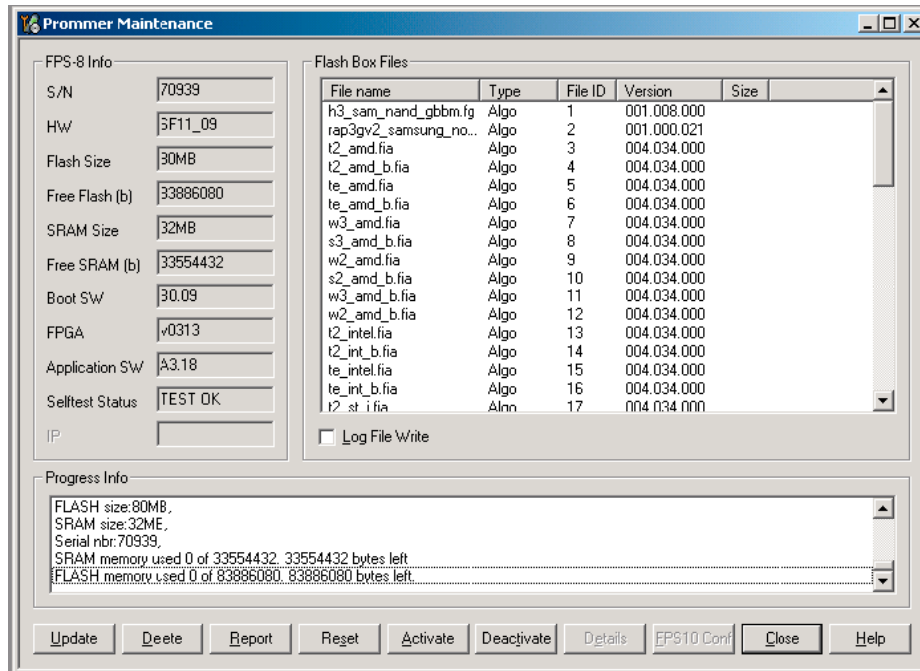

Figure 57 FPS-8 info window

### Alternative steps

- FPS-8 SW can also be updated by pressing Update button and selecting appropriate *fps8upd.ini* file in C:\Program Files\Nokia\Phoenix\Flash.

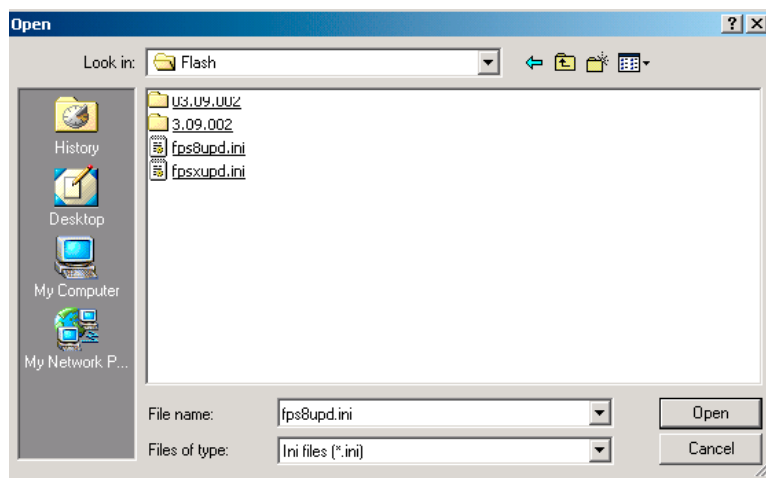

Figure 58 Flash directory window

- All files can be loaded separately to FPS-8. To do this, just press the right mouse button in the *Flash box files* window and select the file type to be loaded. More information can be found in Phoenix Help.

### Activating FPS-8

#### Context

Before FPS-8 can be successfully used for phone programming, it must first be activated. Fill in first the *FPS-8 activation request* sheet in the FPS-8 sales package and follow the instructions on the sheet (included in sales package CD-ROM or from partner web site).

When activation file is received (for example, *00000.in*), copy it to *C:\ProgramFiles\Nokia\Phoenix\BoxActivation* directory on your computer (this directory is created when Phoenix is installed).

### Steps

1. Start *Phoenix Service Software*.
2. Select *Flashing* → *FPS-8 maintenance*.

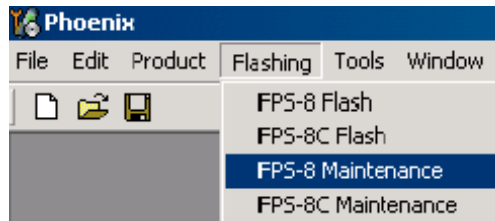

Figure 59 FPS-8 maintenance

3. Click *Activate* in the *FPS-8 Maintenance* window.

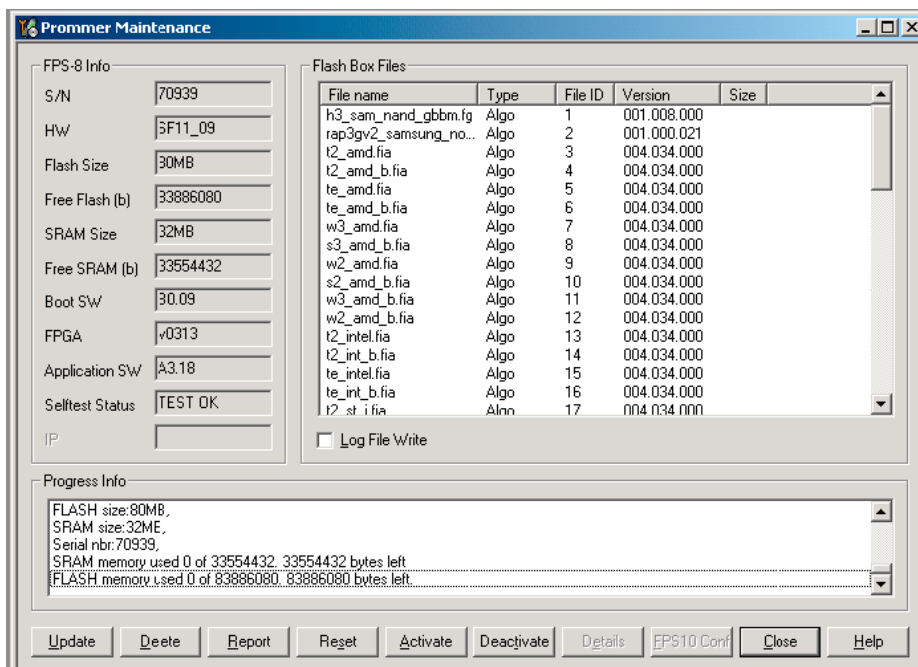

Figure 60 FPS-8 info window

If you saved the activation file to some other directory on your PC, Browse to find it

4. Click Open to activate the box.

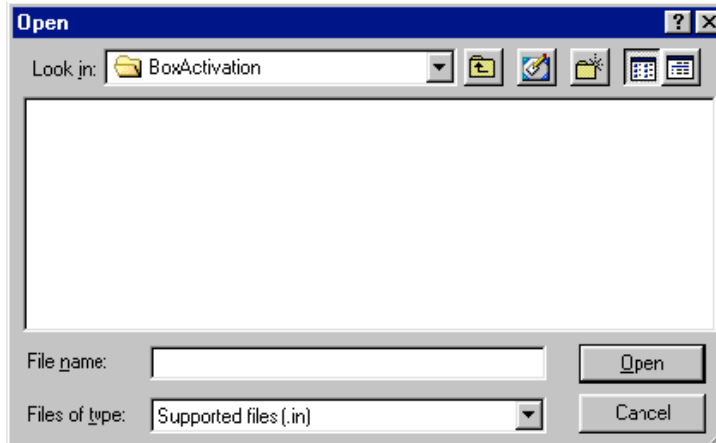

Figure 61 Box activation

5. Turn the FPS-8's power off and on to complete activation.

## Deactivating FPS-8

### Context

If there is, for example, a need to send the FPS-8 box for repair, it must be deactivated first.

### Steps

1. Start *Phoenix Service Software*.
2. Choose *Maintenance* → *Prommer Maintenance*.
3. In the *Prommer Maintenance* window, click Deactivate.
4. To confirm the deactivation, click Yes.

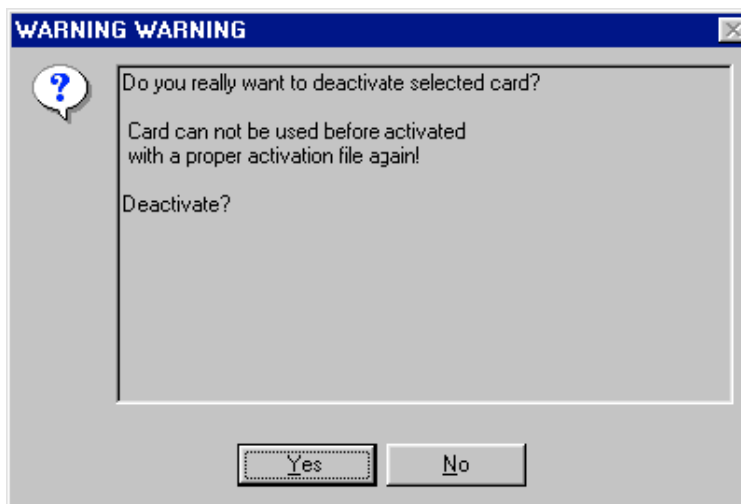

Figure 62 Deactivation warning

The box is deactivated.

5. To complete the deactivation, restart FPS-8.

## Updating JBV-1 docking station software

### Before you begin

The JBV-1 docking station contains software (firmware) which can be updated. You need the following equipment to update the software:

- PC with USB connection
- operating system supporting USB (Not Win 95 or NT)
- USB Cable (can be purchased from shops or suppliers providing PC hardware and accessories)
- JBV-1 docking station
- external power supply (11-16V)

Before installation:

- Download *Jbv1\_18\_update.zip* file to your computer (in *C:\TEMP* for example) from your download web site.
- Close all other programs.
- Follow instructions on the screen.

### Context

The JBV-1 docking station is a common tool for all DCT-4 generation products. In order to make the JBV-1 usable with different phone models, a phone-specific docking station adapter is used.

### Steps

1. Run *Jbv1\_18\_update.zip* file and start software installation by double clicking *Setup.exe*.

**Note:** DO NOT CONNECT THE USB CABLE/JBV-1 TO YOUR COMPUTER YET!

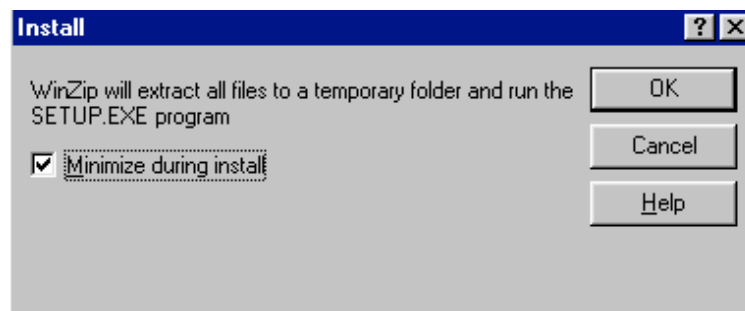

Figure 63 Extracting JBV-1 update files

Files needed for JBV-1 package setup program will be extracted.

2. Read the instructions in the dialog box and click Next to continue.



Figure 64 JBV-1 update information

3. Accept the suggested destination folder for installing the JBV-1 SW Package, and click Next to continue.



Figure 65 JBV-1 update destination folder

4. Select Full installation and click Next to continue.



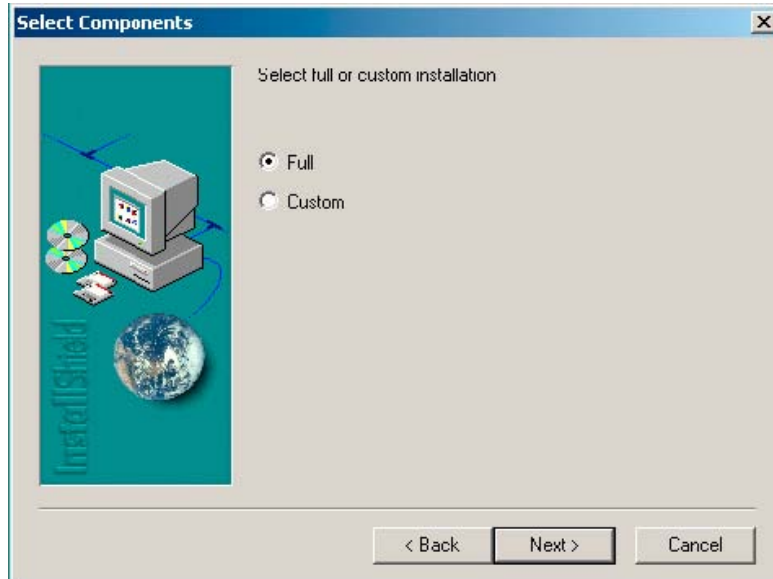

Figure 66 Select installation: Full

5. A program folder is created and the software files are installed there. Click Next to continue.

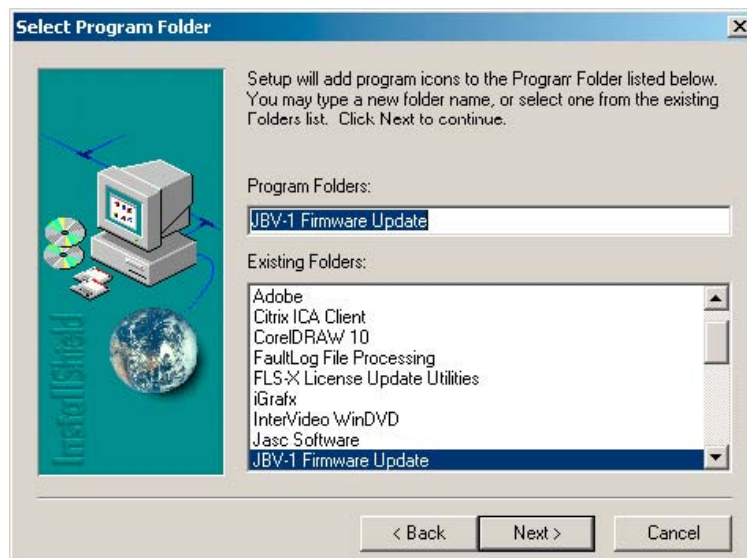

Figure 67 Select program folder

6. Click Finish to complete the installation.

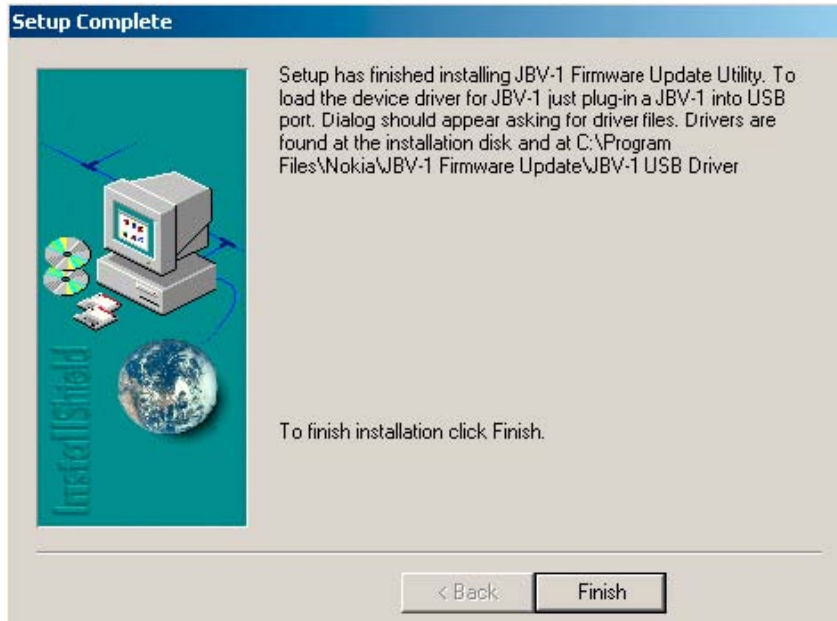

Figure 68 Finish JBV-1 update installation

7. Connect the USB cable/JBV-1 to your computer. Connect power to JBV-1 (11-16V DC) from an external power supply, then connect the USB Cable between the JBV-1 USB connector and the PC.
8. Install or update the JBV-1 USB drivers which are delivered with the JBV-1 SW installation package.

The drivers can be found in *C:\Program Files\Nokia\JBV-1 Firmware Update\JBV-1USB driver*

- If there is no previously installed JBV-1 Firmware update package installed on your computer, Windows will detect connected USB cable and detect drivers for new HW. You will be prompted about this, please follow the instructions and allow Windows to search and install the best drivers available.
- If there is a previously installed JBV-1 Firmware update package (v.17 or older) on your computer, please update the JBV-1 USB driver. Please see the *readme.txt* file in *C:\Program Files\Nokia\JBV-1 Firmware Update\JBV-1USB driver* folder for instructions on how to update the JBV-1 USB Driver.

After you have installed or updated the JBV-1 USB driver, the actual JBV-1 SW update can begin.

9. Go to folder *C:\Program Files\Nokia\JBV-1 Firmware Update\JBV-1 Firmware Update* and start JBV-1 Update SW by double clicking *fwup.exe*.

JBV-1 Firmware update starts and shows current status of the connected JBV-1. If firmware version read from your JBV-1 is not the latest one available (v.17 or older), it needs to be updated to version 18 by clicking Update Firmware.

10. Choose Refresh Status to check the SW version.

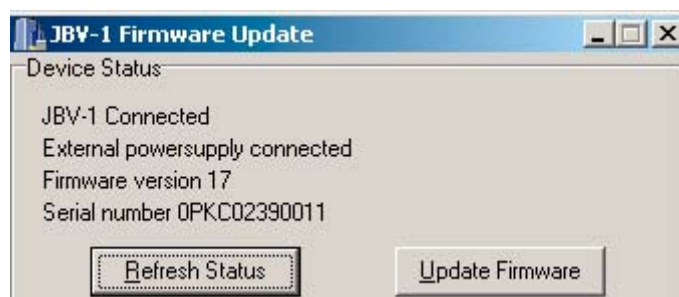

Figure 69 Checking JBV-1 SW version

11. Choose file *JBV1v18.CDE* and click **Open** to update your *JBV-1* to a new version (v.18).

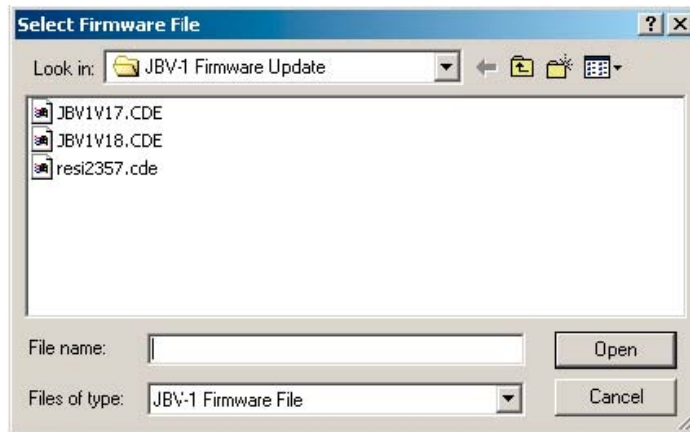

Figure 70 *JBV-1* update directory window

Wait until you hear a "click" from the *JBV-1*.

The older SW file *JBV1v17.CDE* is visible in this view only if the previous *JBV-1* SW package has been installed on your computer.

12. Click **OK** to see the current *JBV-1* status (after a successful update).

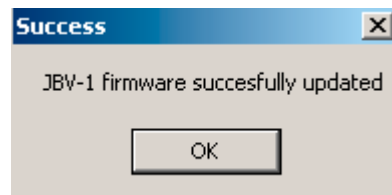

Figure 71 *JBV-1* SW update done

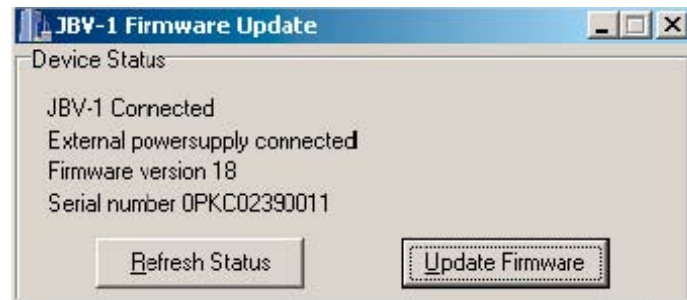

Figure 72 *JBV-1* SW status

You have now updated the software of your *JBV-1* docking station and it is ready for use.

### Next action

If you have several docking stations you need to update, disconnect the power and USB cables from the previous one and connect them to the next docking station. First, click **Refresh Status** to see the current SW version and then **Update Firmware** to update the software.

After you have updated all docking stations, close the *JBV-1 Firmware Update* dialog box.

(This page left intentionally blank.)

## 4 — Service tools and concepts

(This page left intentionally blank.)

## Table of Contents

Service tools.....	4-5
ACF-8.....	4-5
AXS-4.....	4-5
CA-10DS.....	4-5
CA-28DS.....	4-0
CA-31D.....	4-6
CA-35S.....	4-0
CA-41PS.....	4-0
CA-5S.....	4-6
CA-65DS.....	4-0
CA-66DS.....	4-0
CA-67DS.....	4-0
DA-49.....	4-0
DAU-9S.....	4-0
FLC-2.....	4-8
FLS-4S.....	4-8
FPS-10.....	4-0
FPS-11.....	4-9
FPS-8.....	4-9
JBV-1.....	4-0
MJ-59.....	4-0
PCS-1.....	4-0
PKD-1.....	4-0
RJ-51 PA.....	4-0
RJ-72.....	4-0
RJ-79.....	4-0
SA-41.....	4-0
SF-10.....	4-0
SPS-1.....	4-11
SRT-6.....	4-0
SS-54.....	4-0
ST-30.....	4-0
ST-32.....	4-0
SX-4.....	4-0
XCS-4.....	4-13
XRF-1.....	4-0
Service software concept.....	4-14
POS (Point of Sales) flash concept.....	4-14
FPS-8 Prommer box flash concept.....	4-15
FLS-10 Prommer box flash concept.....	4-16
FLS-11 Prommer box flash concept.....	4-17
JBV-1 flash concept with FLS-10.....	4-18
JBV-1 flash concept.....	4-19
Module jig (MJ-59) service concept.....	4-20

### List of Figures

Figure 73 POS flash concept.....	4-14
Figure 74 FPS-8 Prommer box flash concept.....	4-15
Figure 75 FPS-10 Prommer box flash concept.....	4-16

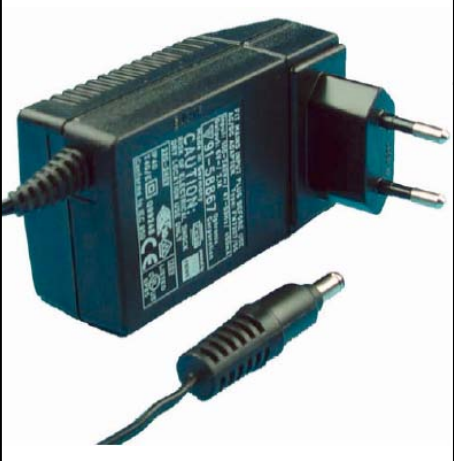



Figure 76 FPS-11 Prommer box flash concept.....4-16  
Figure 77 JBV-1 flash concept with FPS-10.....4-16  
Figure 78 JBV-1 flash concept.....4-16  
Figure 79 Module jig service concept.....4-20











■ Service tools



List of Service Tools



The table below gives a short overview of service tools that can be used for testing, error analysis and repair of product , refer to various concepts.

	ACF-8	Universal power supply	
<p>ACF-8 universal power supply is used to power FPS-8. ACF-8 has 6V DC and 2.1A output.</p>			
	AXS-4	Service cable	
<p>The AXS-4 D9-D9 service cable is used to connect two 9 pin D connectors for example between PC and FPS-8. The cable length is 2 meters.</p>			
	CA-10DS	Bi-directional Parallel Cable	
<p>Bi-Directional parallel cable included in FPS-8 sales pack.</p>			
	CA-28DS	Service data cable	
<p>The CA-28DS service cable is used to connect FLS-4S to the POS flash adapter for supplying a controlled operating voltage and data connection.</p> <p><b>Note:</b> Old XCS-1 cable can be used as well.</p>			

	CA-31D	USB cable	
<p>The CA-31D USB cable is used to connect FPS-10 or FPS-11 to a PC. It is included in the FPS-10 and FPS-11 sales packages.</p>			
	CA-355	Power cable	
<p>Power cable for connecting e.g. the FPS-10 prommer box to the POS flash adapter.</p>			
	CA-41PS	Power cable	
<p>Power cable for connection of e.g. the JBV-1 docking station to the FPS-10 prommer box.</p>			
	CA-5S	DC cable	
<p>The DC cable CA-5S is used to connect JBV-1 to the phone charger jack for ADC/VCHAR/ICHAR calibration</p> <p><b>Note:</b> Old SCB-3 can be used as well.</p>			

	CA-65DS	DS easy flash cable	
<p>The CA-65 DS easy flash cable is used to connect the phone bottom connector to either POS flashing device (FLS-4S) or to the PROMMER box (FPS-11).</p>			
	CA-66DS	Easy flash cable	
<p>This cable connects the phone DC port to the FPS-8 prommer.</p>			
	CA-67DS	Easy flash cable	
<p>This cable connects the phone DC port to the FPS-10 prommer.</p>			
	DA-49	Docking station adapter	
<p>The Docking Station adaptor is used for this phone in combination with JBV-1. The adapter supports flashing and energy management calibration.</p> <p>Features include:</p> <ul style="list-style-type: none"> <li>• compatible with the JBV-1</li> <li>• easy phone attachment and detachment.</li> <li>• reliable phone locking</li> <li>• switch for detecting phone</li> <li>• replaceable SIM interface</li> </ul>			
	DAU-9S	MBUS cable	
<p>The MBUS cable DAU-9S has a modular connector and is used, for example, between the PC's serial port and module jigs, flash adapters or docking station adapters.</p> <p><b>Note:</b> Docking station adapters valid for DCT4 products.</p>			

	<p>FLC-2</p>	<p>DC cable</p>	
<p>FLC-2 is used with a flash adapter to supply a controlled operating voltage.</p>			
	<p>FLS-4S</p>	<p>Flash device</p>	
<p>FLS-4S is a dongle and flash device incorporated into one package, developed specifically for POS use.</p>			
	<p>FPS-10</p>	<p>Flash prommer</p>	
<p>FPS-10 interfaces with:</p> <ul style="list-style-type: none"> <li>• PC</li> <li>• Control unit</li> <li>• Flash adapter</li> <li>• Smart card</li> </ul> <p>FPS-10 flash prommer features:</p> <ul style="list-style-type: none"> <li>• Flash functionality for BB5 and DCT-4 terminals</li> <li>• Smart Card reader for SX-2 or SX-4</li> <li>• USB traffic forwarding</li> <li>• USB to FBUS/Flashbus conversion</li> <li>• LAN to FBUS/Flashbus and USB conversion</li> <li>• Vusb output switchable by PC command</li> </ul> <p>FPS-10 sales package includes:</p> <ul style="list-style-type: none"> <li>• FPS-10 prommer</li> <li>• Power Supply with 5 country specific cords</li> <li>• USB cable</li> </ul>			

	FPS-11	Parallel flash prommer	
	FPS-8	FLASH prommer	
	JBV-1	Docking station	

FPS-11 interfaces with:

- PC
- Control unit
- Flash adapter
- Smart card

FPS-11 flash prommer features:

- Can flash up to 8 phones at a time, controlled by one PC
- Communication method between PC and FPS-11 is single USB2.0
- No need for external power for powering up phones
- Smart Card reader for SX-2 and SX-4
- Updates software
- Future feature: will support all DCT-4 protocols and models

FPS-11 sales package includes:

- FPS-11
- Power Supply for FPS-11
- EUR, UK, USA Power cords
- USB2.0 cable

The flash prommer FPS-8 is used for example with flash adapters, docking station adapters and flash/docking stations. Power is supplied to FPS-8 from the universal power supply, ACF-8.

The sales pack includes:

- FPS-8 flash prommer
- FPS-8 activation sheet
- ACF-8 universal power supply
- AXS-4 service cable (D9-D9)
- Printer cable





The JBV-1 docking station is a general tool that has been designed for calibration and software update use. The JBV-1 is used together with a docking station adapter as one unit





In calibration mode the JBV-1 is powered by an external power supply: 11-16V DC. When flashing the power for the phone must be taken from the flash prommer.



**Note:** JBV-1 main electrical functions are:

- adjustable VBATT calibration voltage, current measurement limit voltage: VCHAR, current measurement: ICHAR
- adjustable ADC calibration voltage via BTEM and the BSI signal
- BTEMP and BSI calibration resistor
- signal from FBUS to the phone via the parallel jig
- control via FBUS or USB
- Flash OK/FAIL indication



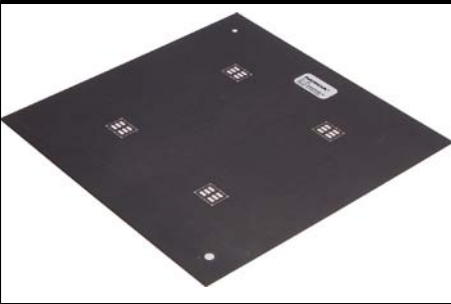

	MJ-59	Module jig	
<p>MJ-59 is meant for component level troubleshooting. The jig includes an RF interface for GSM.</p>			
	PCS-1	Power cable	
<p>The PCS-1 power cable (DC) is used with a docking station, a module jig or a control unit to supply a controlled operating voltage.</p>			
	PKD-1	SW security device	
<p>SW security device is a piece of hardware enabling the use of the service software when connected to the parallel (LPT) port of the PC. Without the device, it is not possible to use the service software. Printer or any such device can be connected to the PC through the device if needed.</p>			
	RJ-51 PA	Rework jig	
<p>To be used with ST-30!</p>			
	RJ-72	Rework jig	
<p>To be used with rework stencil ST-32.</p>			

	RJ-79	Soldering jig	
<p>The soldering jig RJ-79 is used for soldering and as a rework jig for system module. It is made of lead-free rework compatible material.</p>			
	SA-41	RF Coupler	
<p>SA-41 RF Coupler is used for Go/No-Go test after changing components in the RF part of the phone. The SA-41 is mounted on the docking station adapter. <b>Note:</b> For RF attenuation values, please refer to the Service bulletin.</p>			
	SF-10	POS flash adapter	
<p>The POS flash adapter SF-10 allows FBUS/MBUS connections for flashing.</p>			
	SPS-1	Soldering Paste Spreader	
	SRT-6	Opening tool	

	SS-54	Alignment Jig	
<p>Alignment jig is used to efficiently assemble the dome-sheet to the phone's PWB. The jig is made of EDS proof material.</p>			
	ST-30	Rework stencil	
<p>Rework stencil to be used together with RJ-51 to rework the Front End Module (FEM)</p>			
	ST-32	Rework stencil for N7600	
<p>Rework stencil to be used together with RJ-72 for rework of N7600.</p>			
	SX-4	Smart card	
<p>SX-4 is a BB5 security device used to protect critical features in tuning and testing. SX-4 is also needed together with FPS-10 when DCT-4 phones are flashed.</p>			



 <p>A black modular cable with two RJ45 connectors at both ends. The cable is coiled and has a small white label near the center.</p>	XCS-4	Modular cable	
<p>XCS-4 is a shielded (one specially shielded conductor) modular cable for flashing and service purposes.</p>			
 <p>A black RF cable with an SMA connector on one end and an N-Connector on the other. The cable is coiled and has a small white label near the SMA connector.</p>	XRF-1	RF cable	
<p>The RF cable is used to connect, for example, a module repair jig to the RF measurement equipment. SMA to N-Connector ca. 610mm. Attenuation for:</p> <ul style="list-style-type: none"> <li>• GSM850/900: 0.3+-0.1 dB</li> <li>• GSM1800/1900: 0.5+-0.1 dB</li> <li>• WLAN: 0.6+-0.1dB</li> </ul>			

■ Service software concept

POS (Point of Sales) flash concept

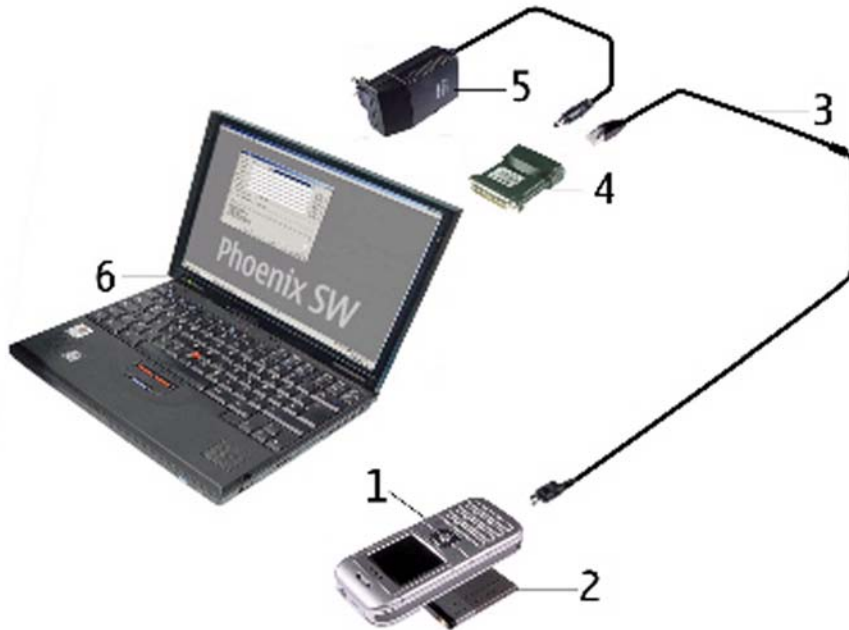

Figure 73 POS flash concept

Item	Description	Type
1	Phone	
2	Battery	
3	Easy flash cable	CA-65DS
4	FLS-4S sales pack	FLS-4S
5	AC charger	ACF-8
6	PC with Service SW CD-ROM	

**FPS-8 Prommer box flash concept**

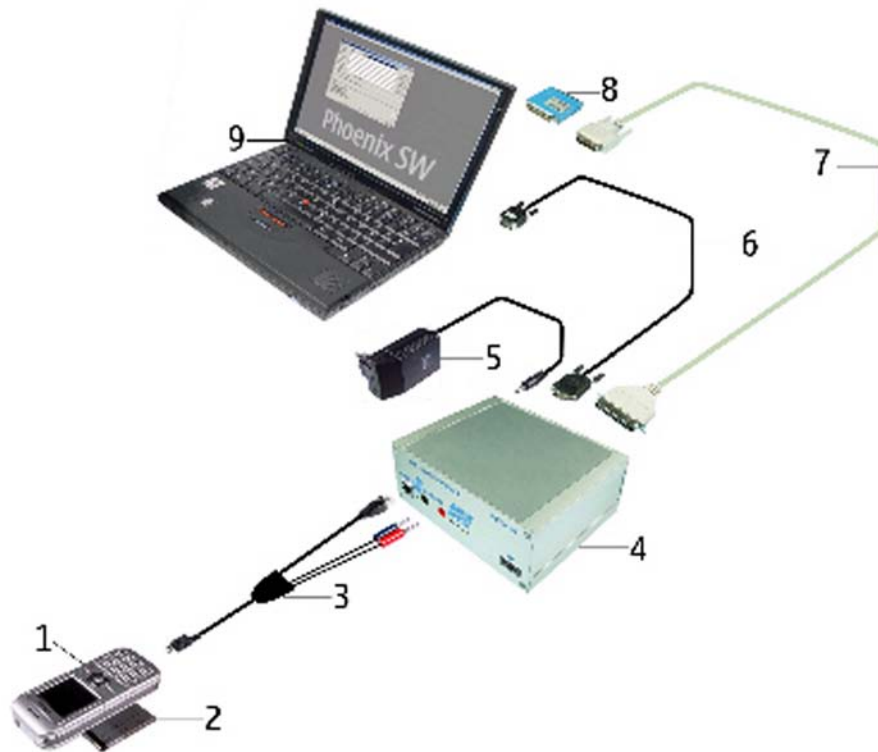

Figure 74 FPS-8 Prommer box flash concept

Item	Description	Type
1	Phone	
2	Battery	
3	Service cable	CA-66DS
4	Flash prommer box sales pack including 2 pcs SF12 SRAM	FPS-8
5	AC Charger, included in FPS-8 sales package	ACF-8
6	RS-232 (D9 – D9) cable, included in FPS-8 sales pack	AXS-4
7	Printer cable, included in FPS-8 sales package	
8	Software protection key	PKD-1
9	PC with service SW	

**FLS-10 Prommer box flash concept**

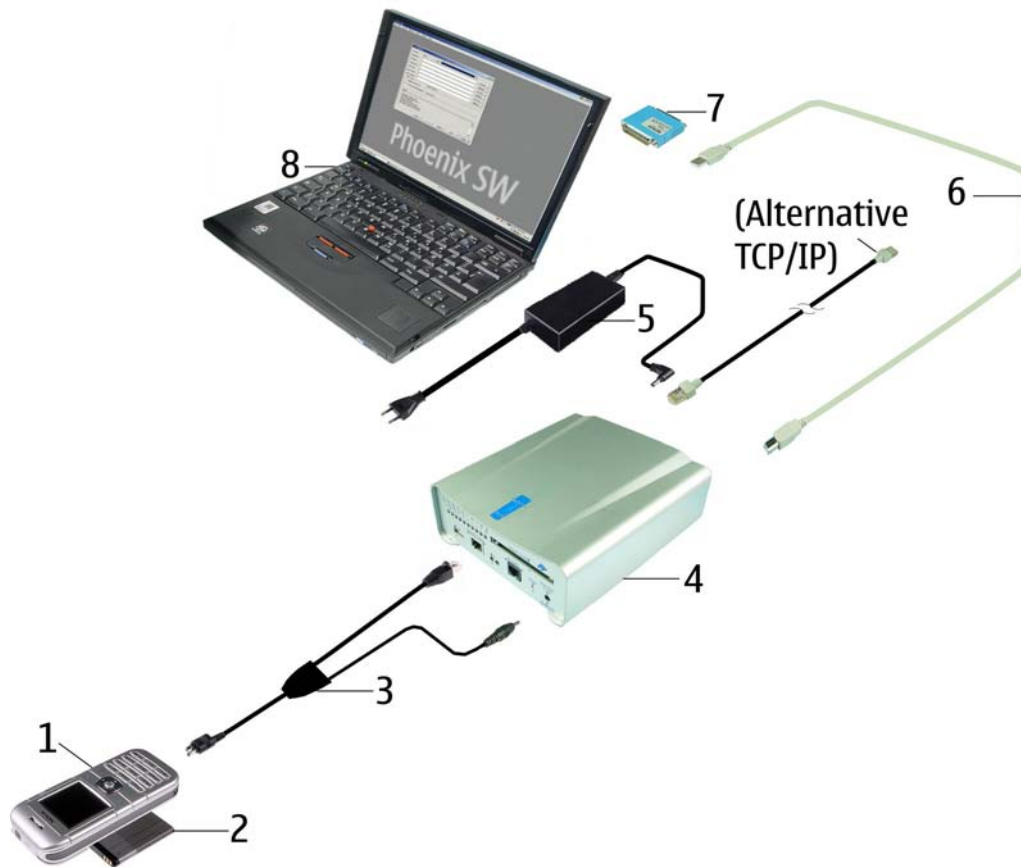

Figure 75 FPS-10 Prommer box flash concept

Item	Description	Type
1	Battery	
2	Phone	
3	Service cable	CA-67DS
4	Flash prommer box sales pack	FPS-10
5	Power supply, included in FPS-10 sales package	AFC-8
6	USB A to B cable	CA-31D
7	Software protection key	PKD-1
8	Service SW (PHOENIX)	

**FLS-11 Prommer box flash concept**

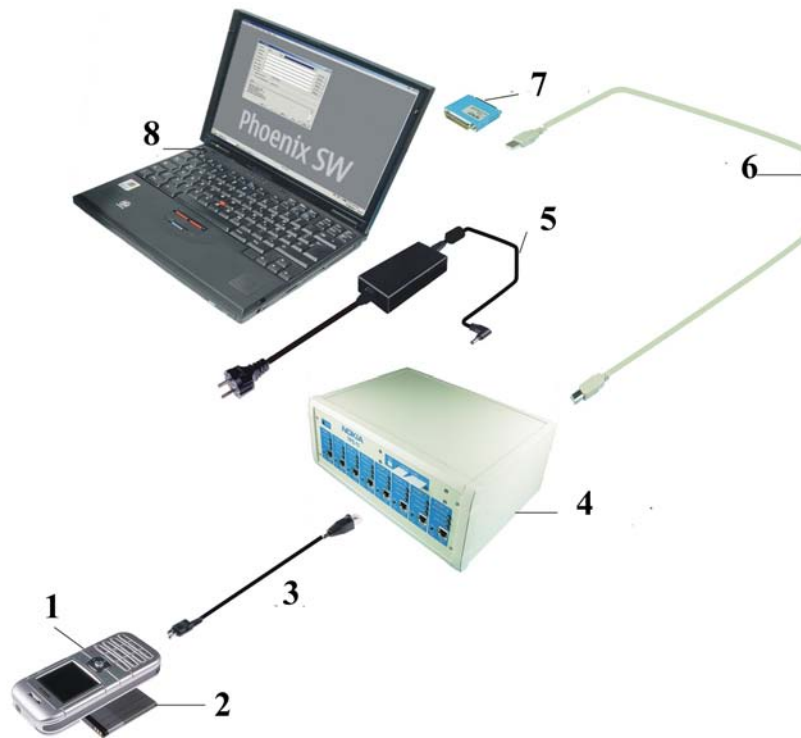

Figure 76 FPS-11 Prommer box flash concept

Item	Description	Type
1	Phone	
2	Battery	BL-5C
3	DC power cable	CA-65DS
4	Flash prommer box sales pack	FPS-11
5	Power supply, included in FPS-11 sales package	
6	USB A to B cable	CA-31D
7	Software protection key	PKD-1
8	Service SW (PHOENIX)	

**JBV-1 flash concept with FLS-10**

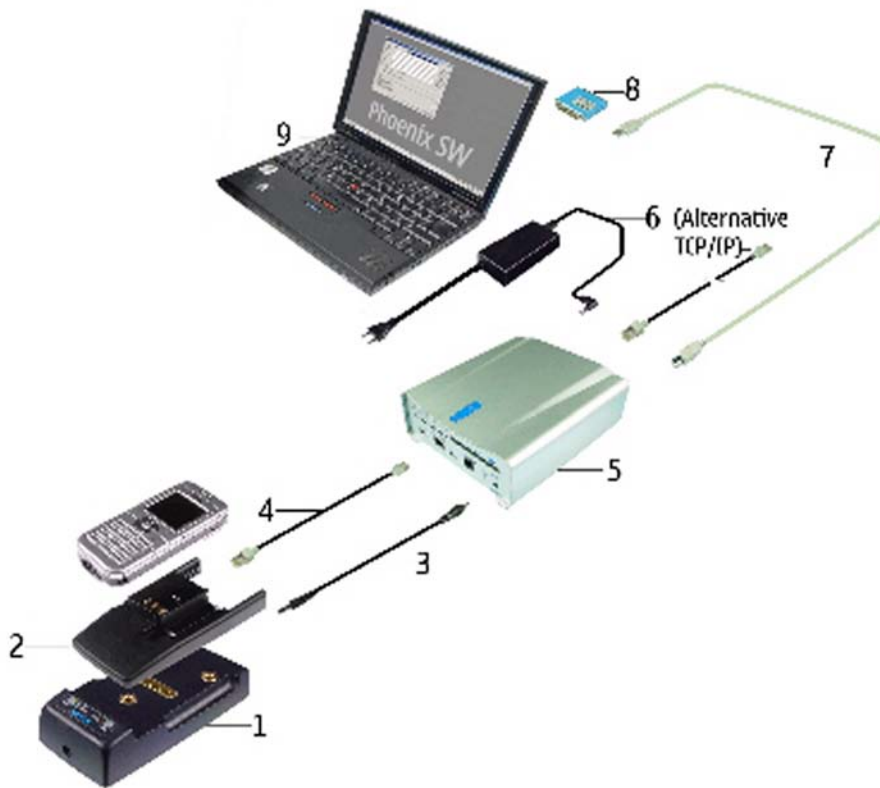

Figure 77 JBV-1 flash concept with FPS-10

Item	Description	Type
1	Docking station	JBV-1
2	Docking station adapter	DA-49
3	DC power cable	CA-41PS
4	Modular cable	XCS-4
5	Flash prommer box sales pack	FPS-10
6	Power supply, included in FPS-10 sales package	AFC-8
7	USB A to B cable	CA-31D
8	Software protection key	PKD-1
9	Service SW (PHOENIX)	

**JBV-1 flash concept**

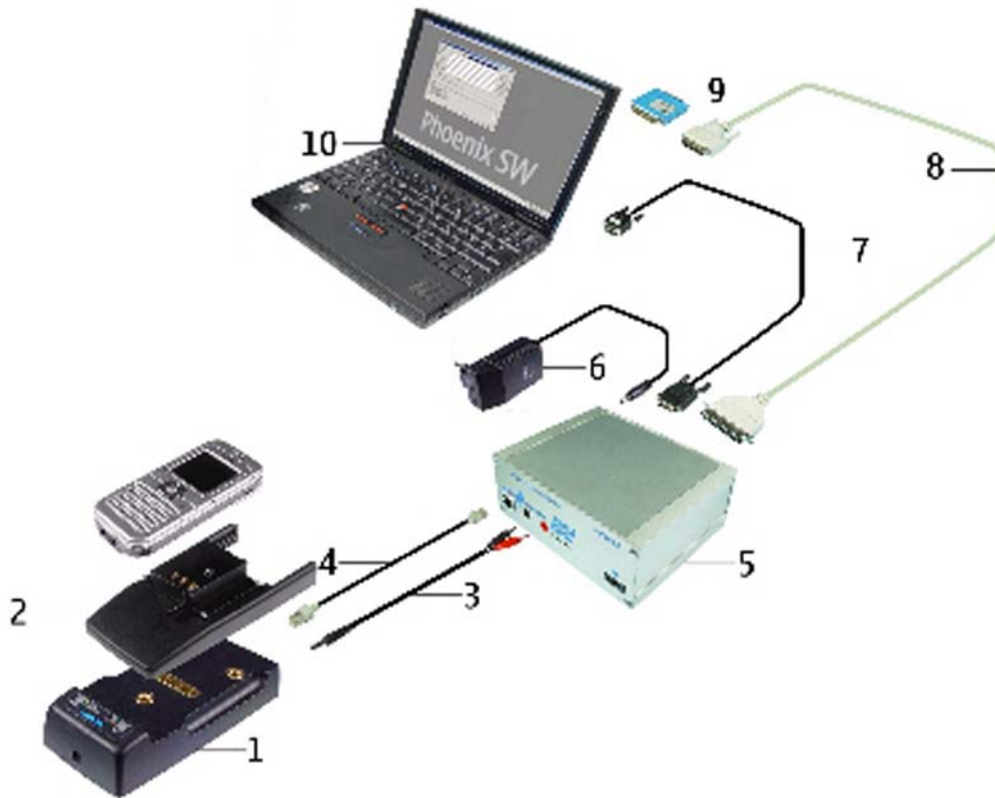

Figure 78 JBV-1 flash concept

Item	Description	Type
1	Docking station	JBV-1
2	Docking station adapter	DA-49
3	DC power cable	PCS-1
4	Modular cable	XCS-4
5	Flash prommer box sales pack	FPS-8
6	Power supply, included in FPS-8 sales package	AFC-8
7	RS-232 (D9 – D9) cable, included in FPS-8 sales package	AXS-4
8	Printer cable, included in FPS-8 sales package	
9	Software protection key	PKD-1
10	Service SW (PHOENIX)	

**Module jig (MJ-59) service concept**

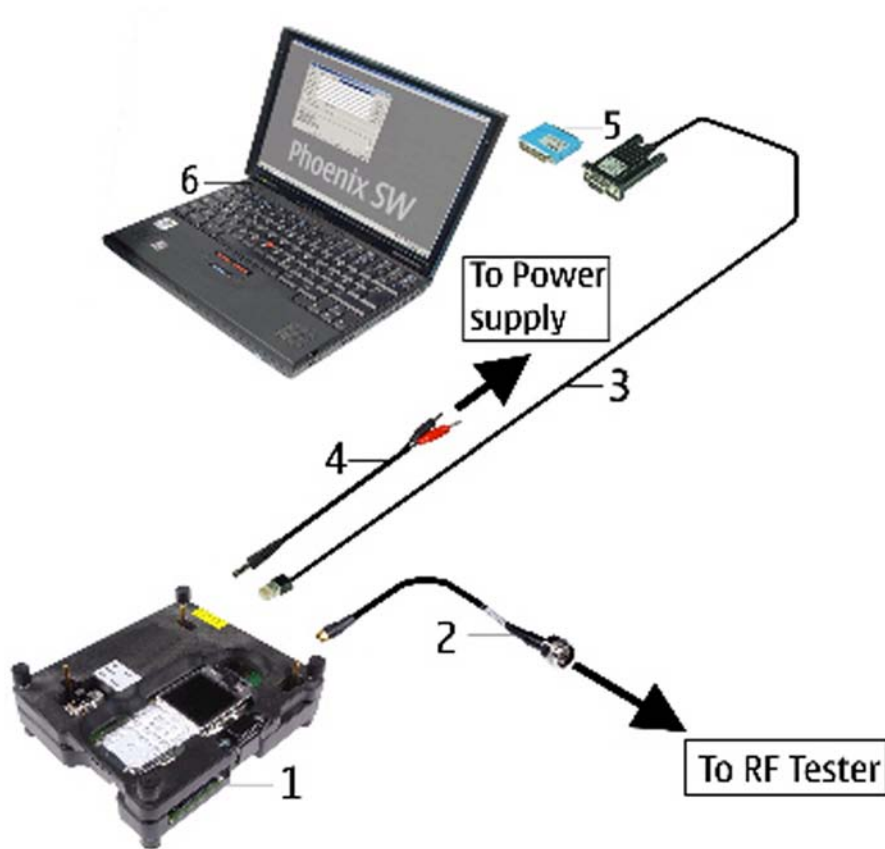

Figure 79 Module jig service concept

Item	Description	Type
1	Module jig	MJ-59
2	RF test cable	XCF-4
3	Service MBUS/FBUS cable	DAU-9S
4	DC power cable	PCS-1
5	Software protection key	PKD-1
6	PC with Service SW (PHOENIX)	



## **5 — Disassembly and reassembly instructions**

(This page left intentionally blank.)

## Table of Contents

Disassembly instructions.....	5-5
Reassembly instructions.....	5-9

(This page left intentionally blank.)

## ■ Disassembly instructions

### Steps

1. Tools needed for disassembly and reassembly.



2. Protect the window with a film.



3. Press the *release button* and remove the *B-cover*.



4. Use the STR-6 to unlock the *A-cover* on both sides.



5. Remove the *A-cover*. Always start on the top side of the device when reassembling the *A-cover*.



6. Remove the *keymat* and protect the inner side of the window with a film.



7. Unscrew the six *Torx Plus size 6 screws* in the shown order. For reassembly, use the reverse order and a *Torx Plus size 6 driver* with a torque setting of 24 Ncm.

**Note:** For reassembly, ALWAYS USE NEW SCREWS!

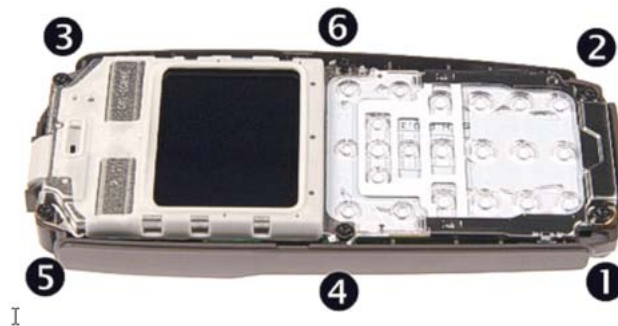

8. Lift the *LCD shielding* while carefully pressing on the *LCD module* with a clean cloth.



9. Remove the *LCD shielding*.



10. Remove the *acoustic channel*.

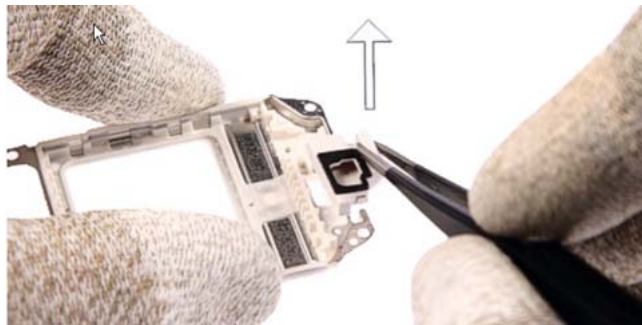

11. Protect the *LCD module* with a film.

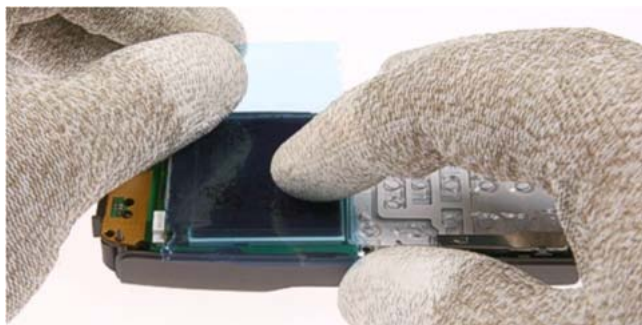

12. Take care of the surrounding components when opening the *LCD connector*.

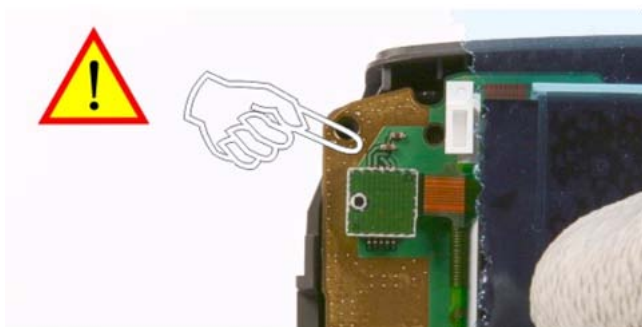



13. Use the SRT-6 to open the LCD connector in the shown order. Be extra careful with the *flex foil* of the *LCD module*.

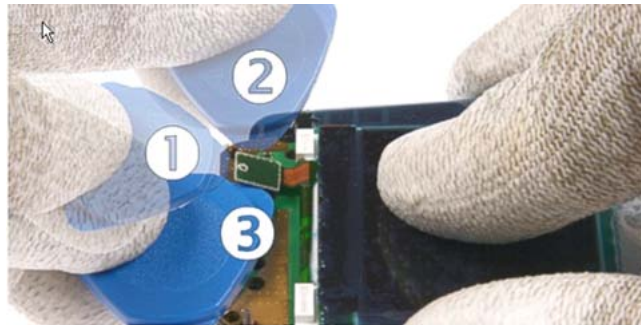

14. Remove the *LCD module*.



15. Remove the *light guide assembly*.



16. Lift the *engine module* a bit with the SRT-6 and remove it from the *D-cover assembly*.

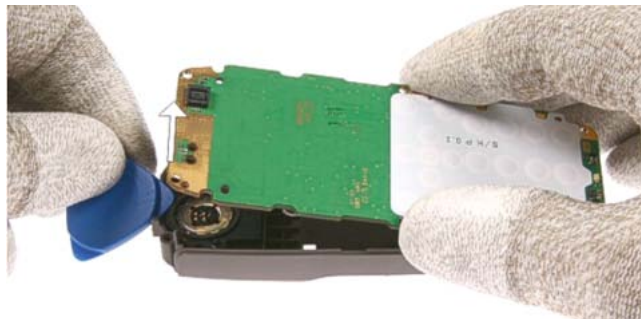



17. The *antenna IHF assembly* drops out when turning the *D-cover assembly*.



18. Press out the *Easy Flash connector* by using the DC-plug.

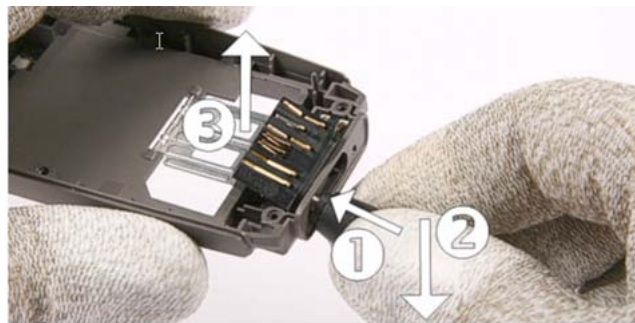

19. Remove the *microphone* with the slotted screwdriver.

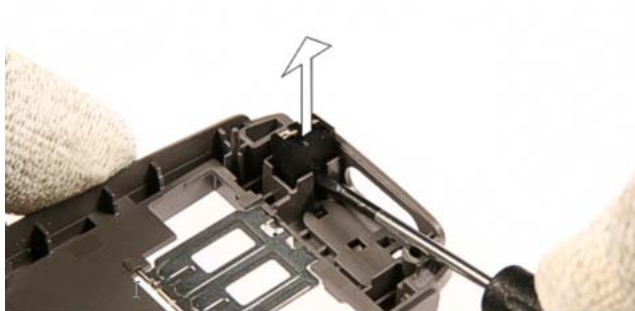

### ■ Reassembly instructions

For reassembly, follow the instructions for disassembly, but *in reversed order*.

**Note:** Pay extra attention to steps 7 and 5.

(This page left intentionally blank.)

## 6 — Baseband troubleshooting

(This page left intentionally blank.)

## Table of Contents

General baseband troubleshooting.....	6-5
Phone is dead.....	6-5
Flash programming do not work.....	6-6
Easy flash programming does not work.....	6-8
Power does not stay on or the phone is jammed.....	6-9
Display shows "Contact Service".....	6-10
The phone does not register to the networks, or the phone can not make a call.....	6-11
SIM related faults.....	6-12
Insert SIM card fault.....	6-12
SIM card rejected.....	6-13
User interface.....	6-14
Blank display.....	6-14
Display is corrupt.....	6-14
Dead keys.....	6-15
No backlight for display or keys.....	6-15
Audio troubleshooting.....	6-17
Audio troubleshooting using phoenix.....	6-17
Check microphone using "Hp microphone in Ext speaker out" loop.....	6-18
Check earpiece using "Ext microphone in Hp speaker out" loop.....	6-19
Check IHF & ringing tone function using "Buzzer".....	6-19
Check vibra function using "Vibra control".....	6-20
Earpiece fault.....	6-21
IHF/ringing tone fault.....	6-22
Headset earpiece fault.....	6-23
Microphone fault.....	6-24
Headset microphone fault.....	6-25

## List of Figures

Figure 80 Phone is dead troubleshooting.....	6-6
Figure 81 Flash programming fault.....	6-7
Figure 82 Easy flash programming fault.....	6-9
Figure 83 Power does not stay on or the phone is jammed.....	6-10
Figure 84 Troubleshooting when the "Contact Service" message is seen.....	6-11
Figure 85 No registering or call.....	6-12
Figure 86 Insert SIM card fault.....	6-13
Figure 87 Signal diagram.....	6-13
Figure 88 Signal diagram.....	6-14
Figure 89 Blank display.....	6-14
Figure 90 Display is corrupt.....	6-15
Figure 91 Dead keys.....	6-15
Figure 92 No backlight for display or keys.....	6-16
Figure 93 Phoenix audio test window.....	6-17
Figure 94 PWB audio test points.....	6-18
Figure 95 Test arrangement for microphone.....	6-19
Figure 96 Test arrangement for of earpiece.....	6-19
Figure 97 Checking IHF and ring tone by using "Buzzer".....	6-20
Figure 98 Checking vibra function by using vibra control.....	6-20
Figure 99 Earpiece fault flow chart.....	6-21
Figure 100 IHF/ringing tone fault flow chart.....	6-22

Figure 101 Headset earpiece fault flow chart.....6-23  
Figure 102 Microphone fault flow chart.....6-24  
Figure 103 Headset microphone fault flow chart.....6-25

## ■ General baseband troubleshooting

### Phone is dead

#### Context

This means that the phone does not use any current at all when the supply is connected and/or power key is pressed. It is assumed that the voltage supplied is 3.6VDC. The UEMCLite will prevent any functionality at battery/supply levels below 2.9VDC.

**Context**

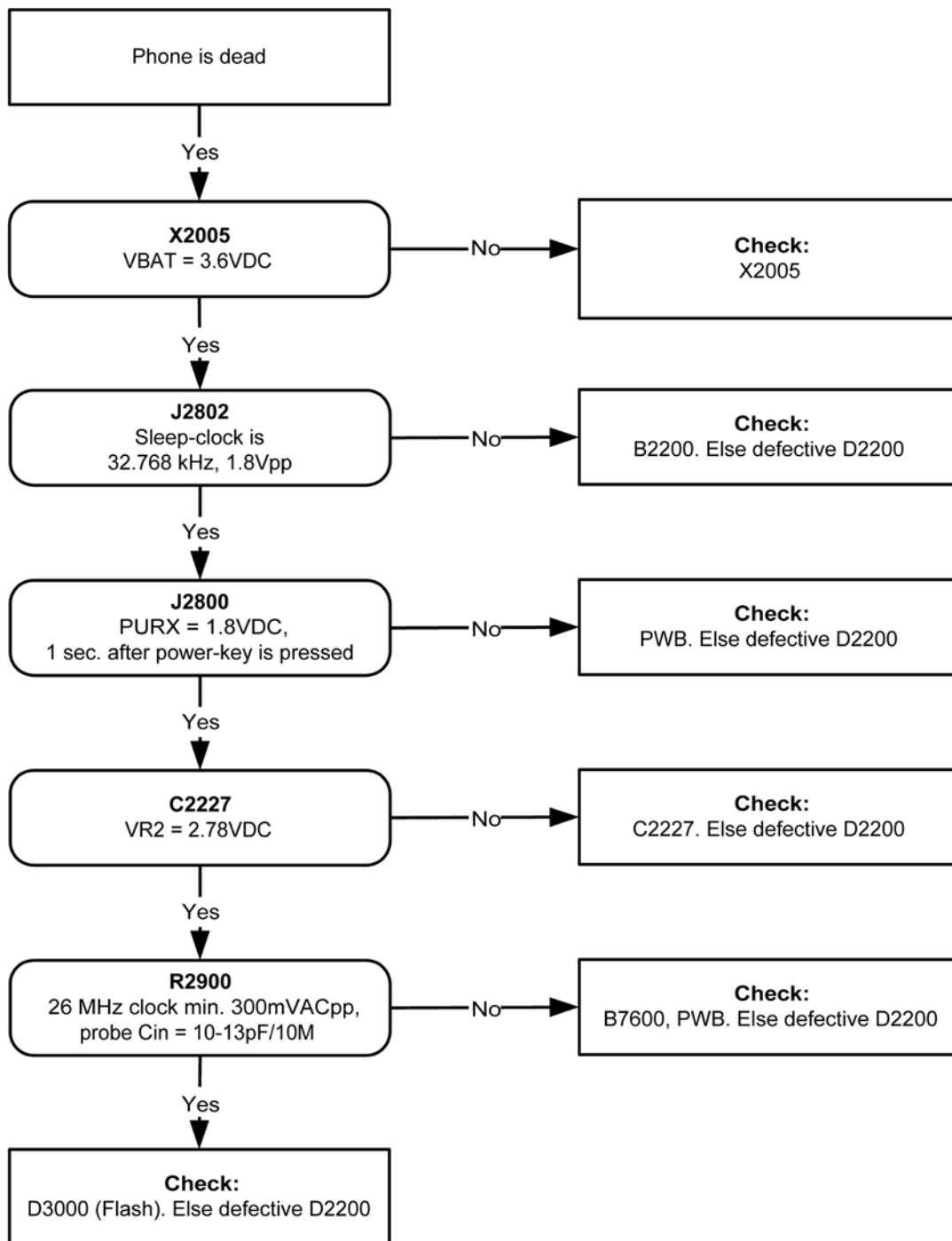

Figure 80 Phone is dead troubleshooting

**Flash programming do not work**

The flash programming can be done via the pads on the PWB (J2060).



In case of Flash failure in FLALI station, swap the phone and send it back to the care program for further analysis. Possible failures could be short-circuit of balls under  $\mu$ BGAs (JEMCLite, UPP4M, FLASH). Missing or misaligned components. In flash programming error cases the flash prommer can give some information about a fault. The fault information messages could be:

*Phone doesn't set FBUS\_TX line low*

Because of the use of  $\mu$ BGA components it is not possible to verify if there is a short circuit in control- and address lines of MCU (UPP4M) and memory (flash).

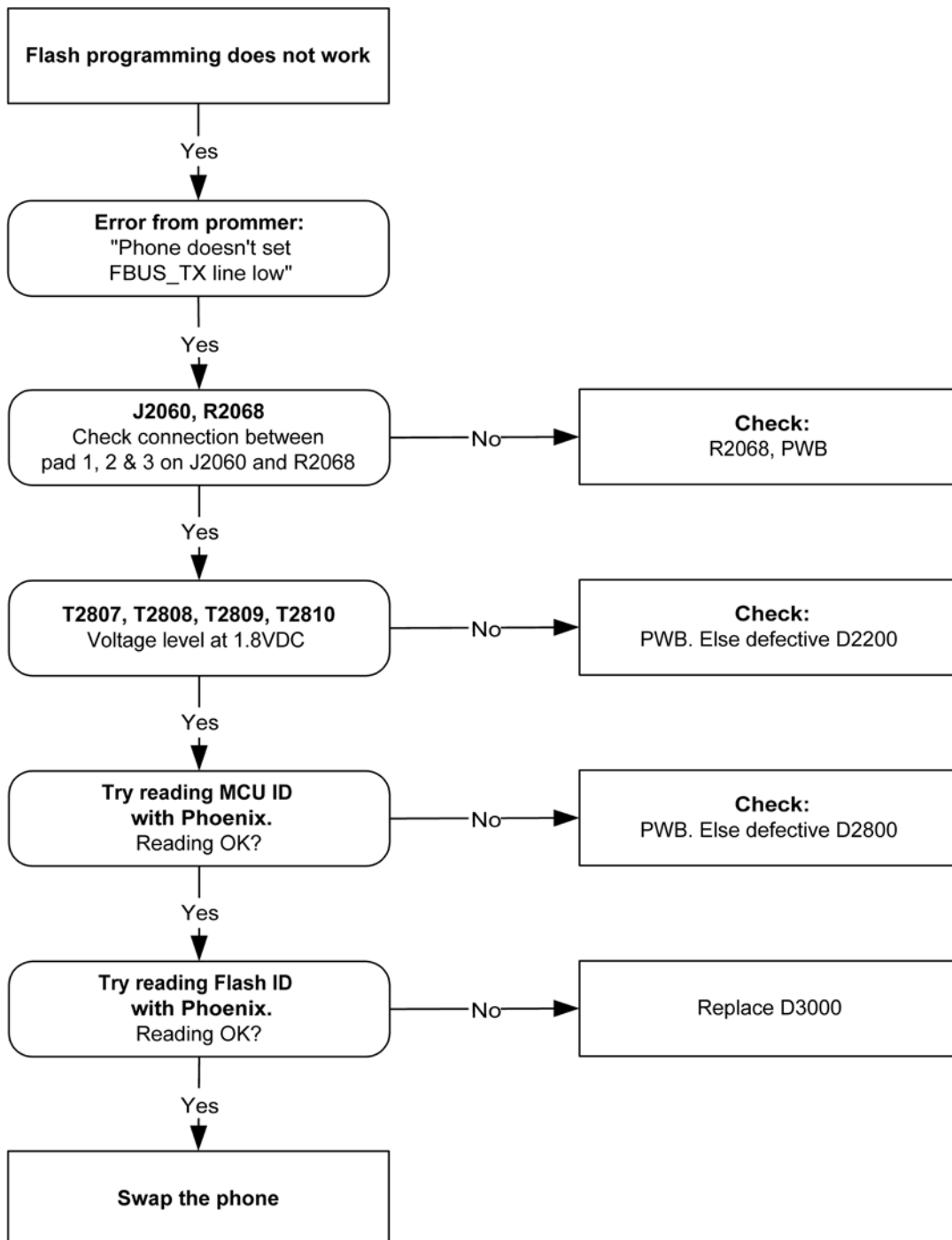

Figure 81 Flash programming fault

### **Easy flash programming does not work**

The flash programming can also be done via the easy flash connector.

In case of Flash failure in FLALI station, swap the phone and send it back to the care program for further analysis. Possible failures could be short-circuit of balls under  $\mu$ BGAs (UEMCLite, UPP4M, FLASH). Missing or misaligned components.

In flash programming error cases the flash prommer can give some information about a fault. The fault information messages could be:

- Phone does not set FBUS\_TX line low

Because of the use of uBGA components it is not possible to verify if there is a short circuit in control- and address lines of MCU (UPP4M) and memory (flash).

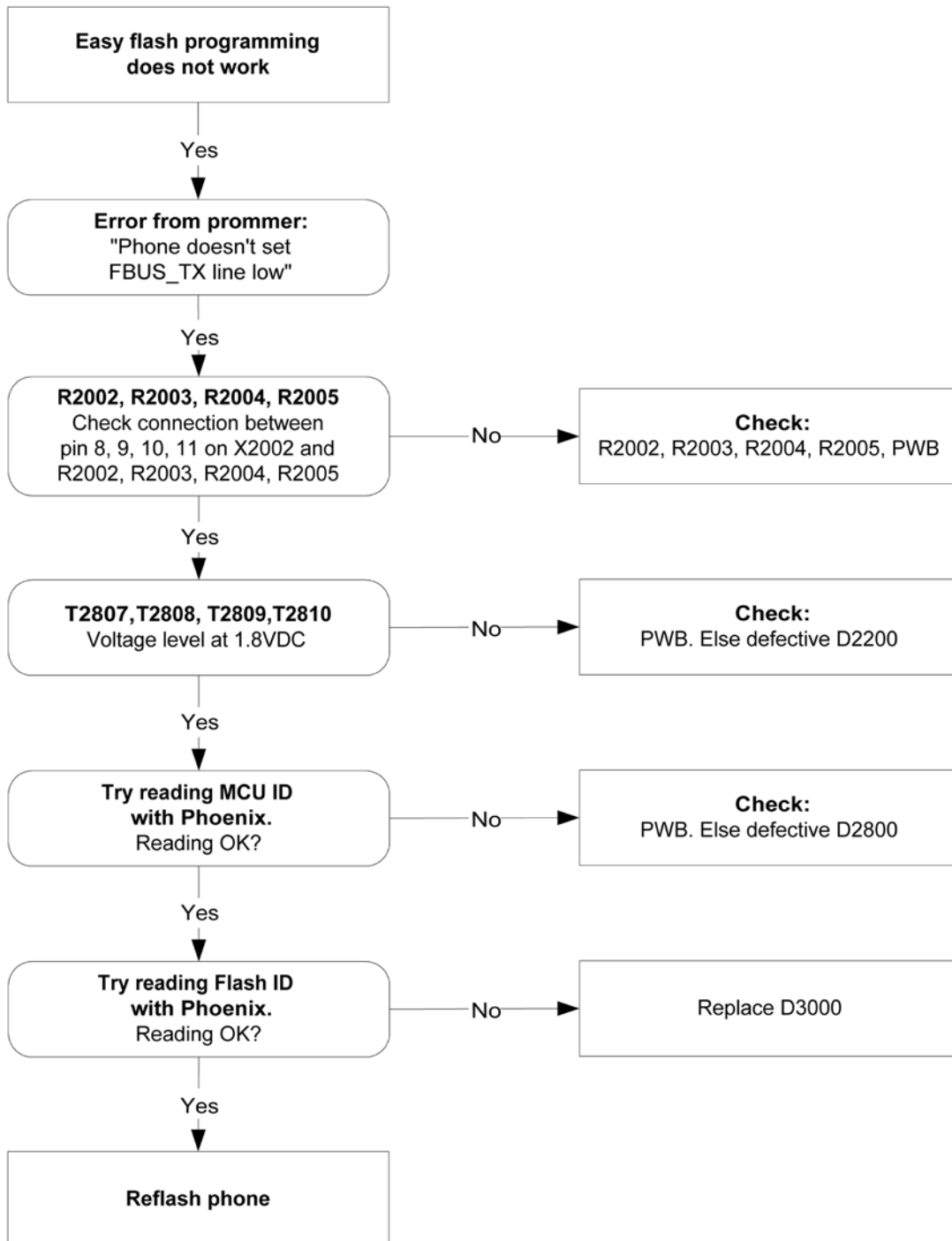

Figure 82 Easy flash programming fault

### Power does not stay on or the phone is jammed

If this kind of a failure is presenting itself immediately after FLALI, it is most likely caused by ASIC's missing contact with PWB.

If the MCU doesn't service the watchdog register within the UEMCLite, the operations watchdog will run out after approximately 32 seconds. Unfortunately, the service routine can not be measured.

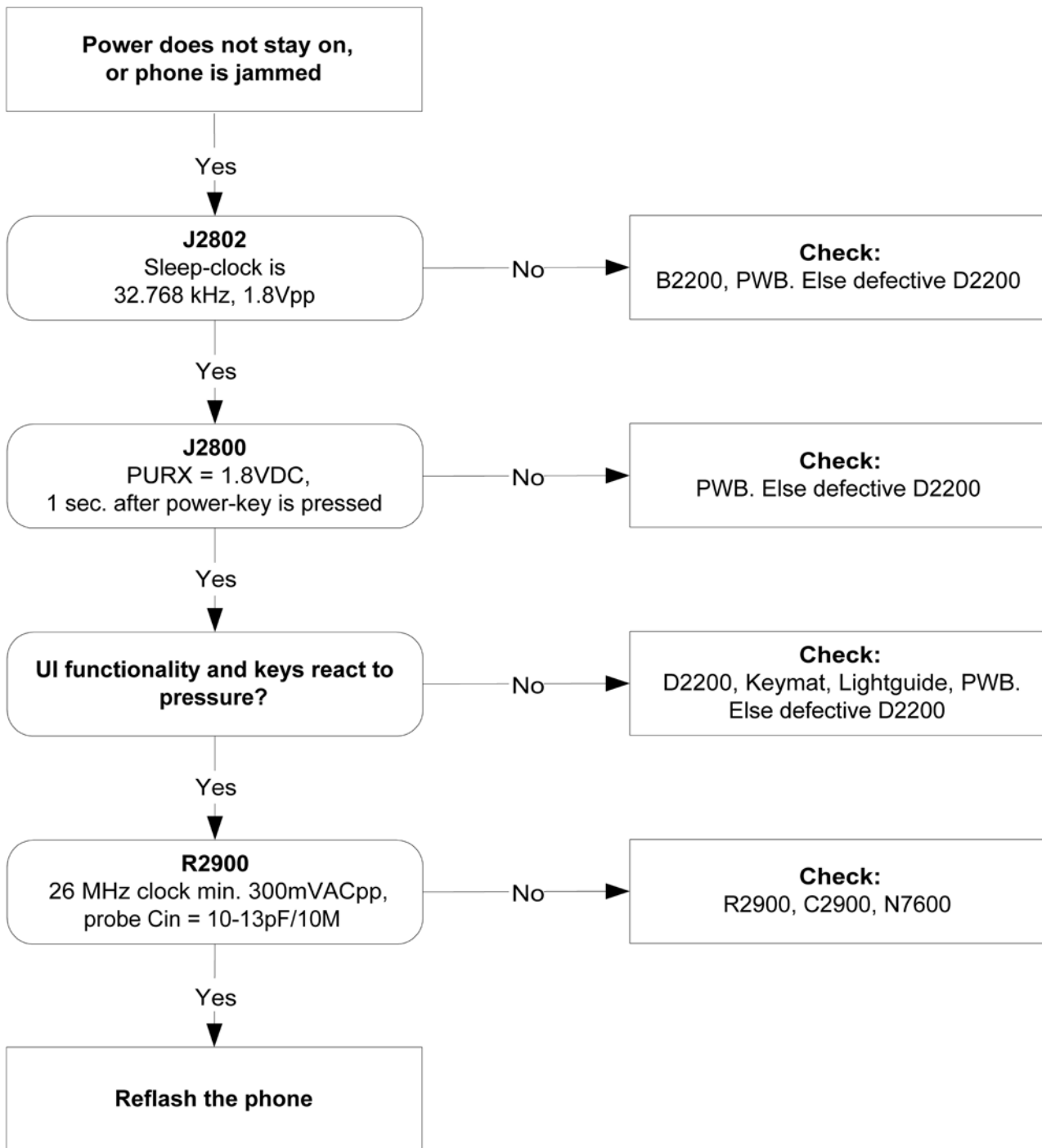

Figure 83 Power does not stay on or the phone is jammed

### Display shows "Contact Service"

This error can only happen at power up where several self-tests is run. If any of these test cases fails the display will show the message: "Contact Service".

It's individual test cases so the below lineup of error hunting's has no chronological order. Use common sense and experience to decide which test case to start error hunting at.

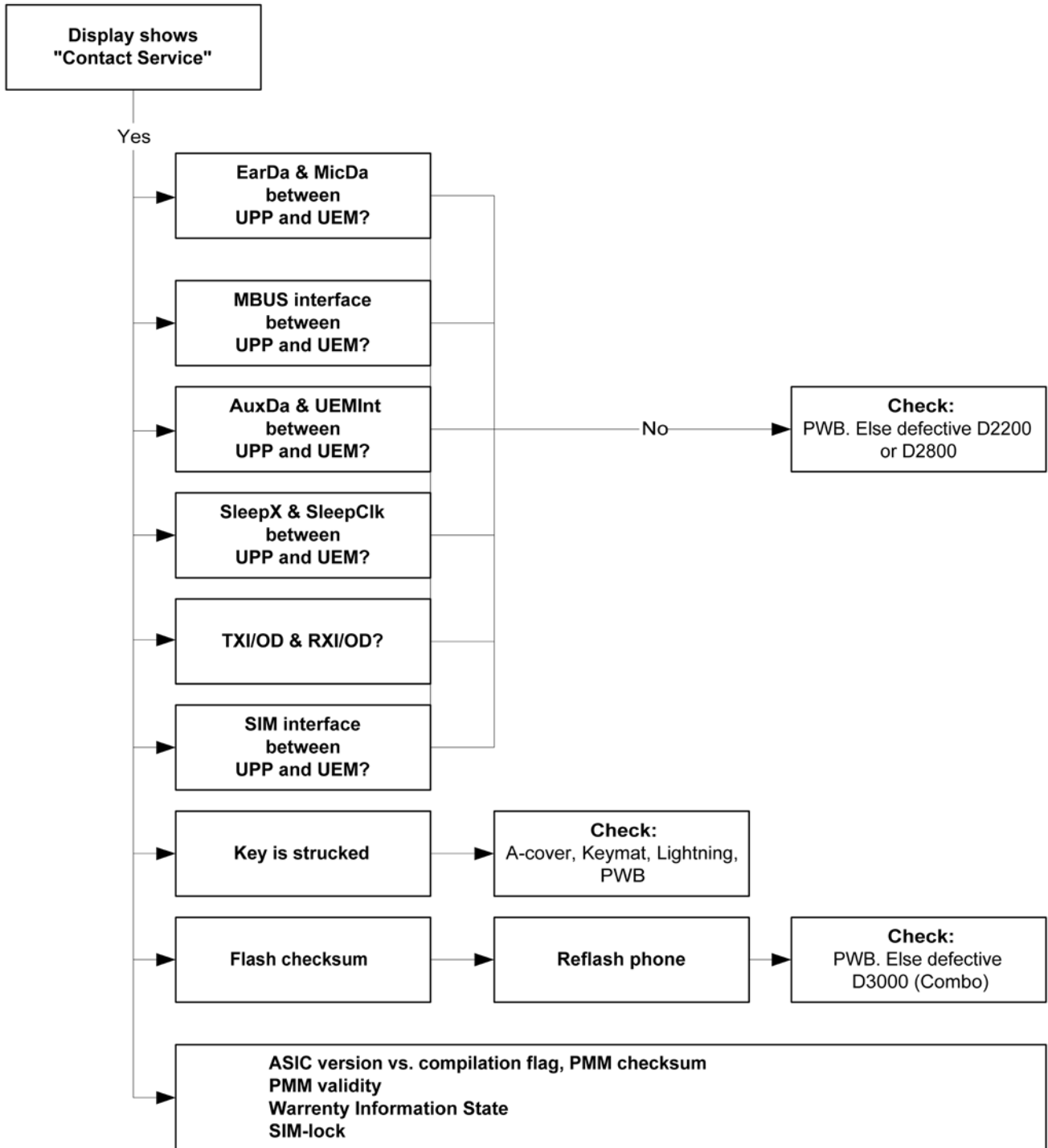

Figure 84 Troubleshooting when the "Contact Service" message is seen

**The phone does not register to the networks, or the phone can not make a call**

If the phone doesn't register to the network, the fault can be in either BB or RF. Only few signals can be tested since several signals is 'buried' in one or more of the inner layers of the PWB.

First of all check that SIM LOCK is not causing the error by using a Test-SIM card and connect the phone to a tester.

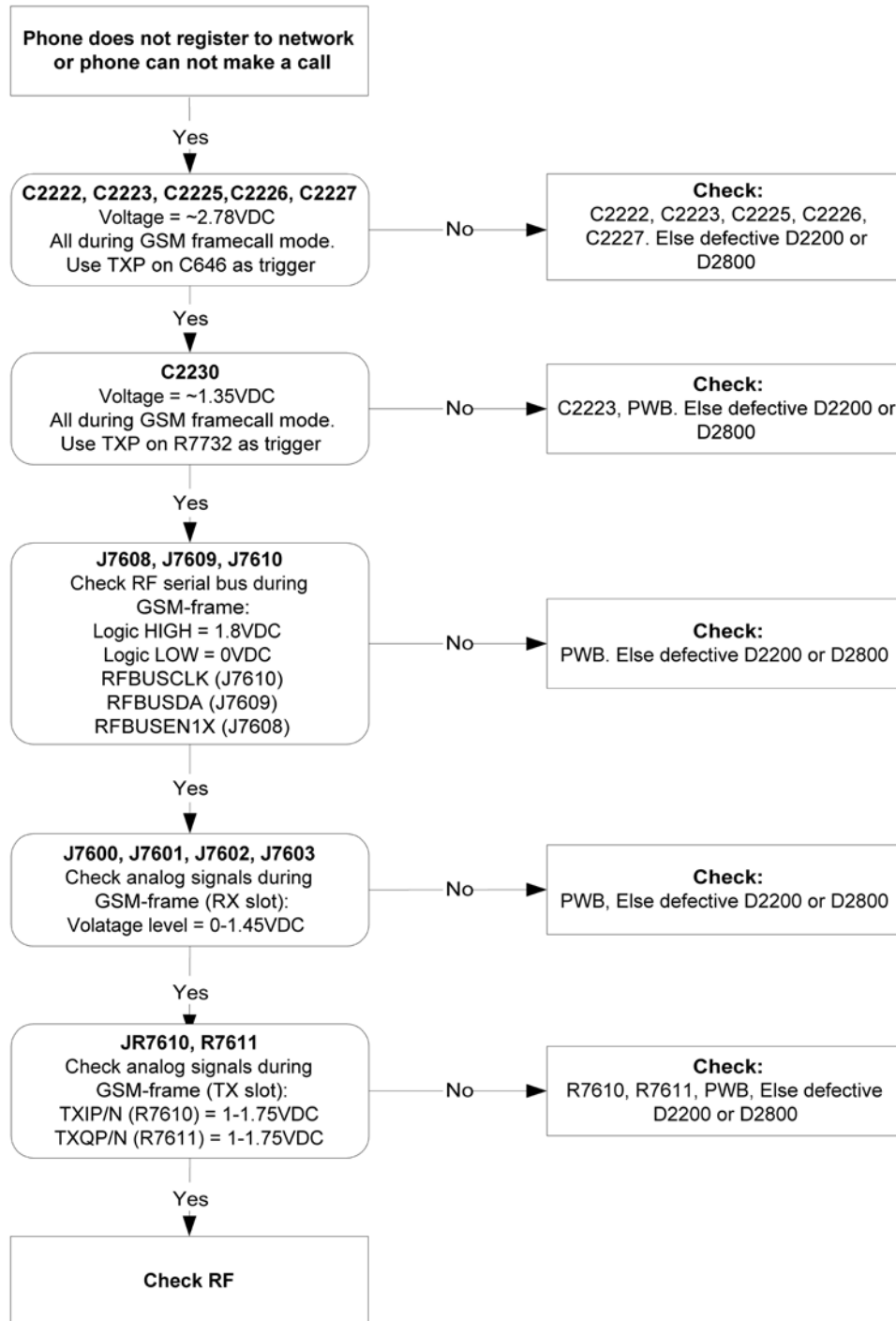

Figure 85 No registering or call

## ■ SIM related faults

### Insert SIM card fault

The hardware of the SIM interface from UEMCLite (D2200) to the SIM connector (X2700) can be tested without a SIM card. When the power is switched on the phone first check for a 1.8SIM card and then a 3V SIM card. The phone will try this four times, where after it will display "Insert SIM card".

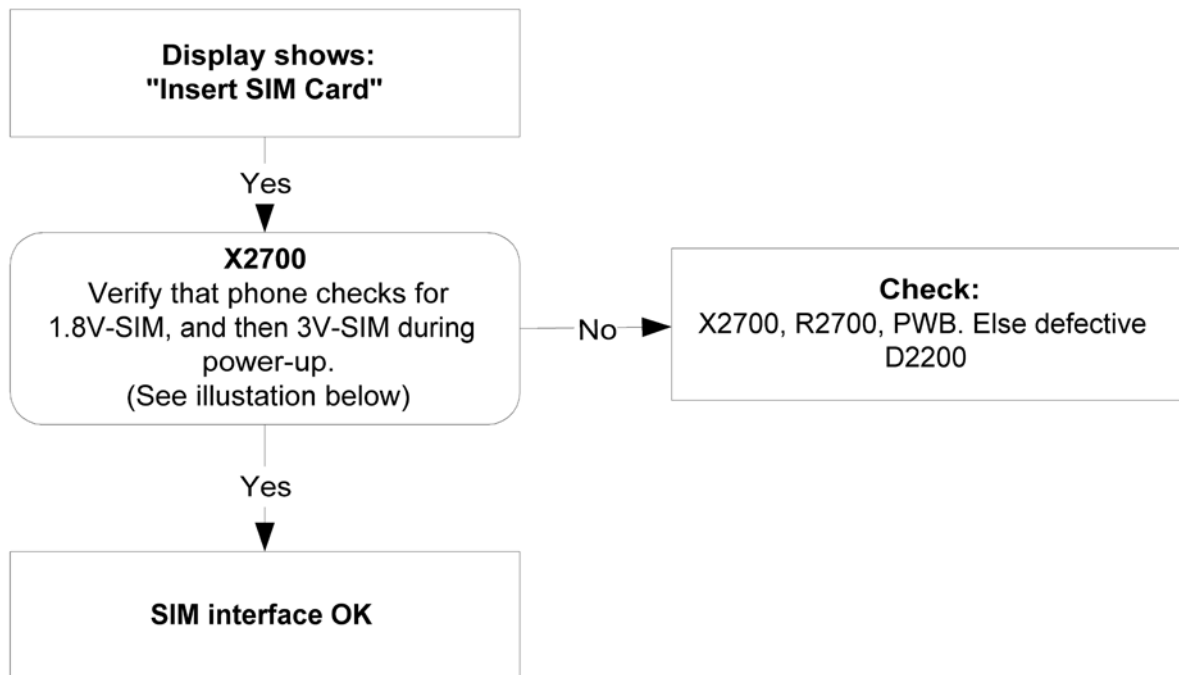

Figure 86 Insert SIM card fault

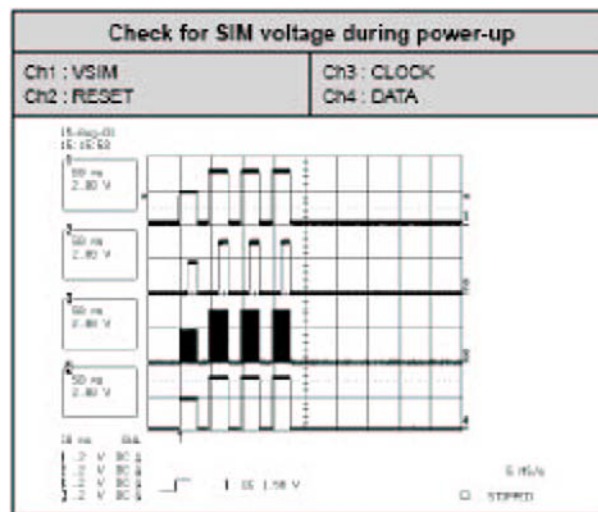

Figure 87 Signal diagram

### SIM card rejected

The error "SIM card rejected" means that the ATR message received from SIM card is corrupted, e.g. data signal levels are wrong. The first data is always ATR and it is sent from card to phone.

For reference a picture with normal SIM power-up is shown below.

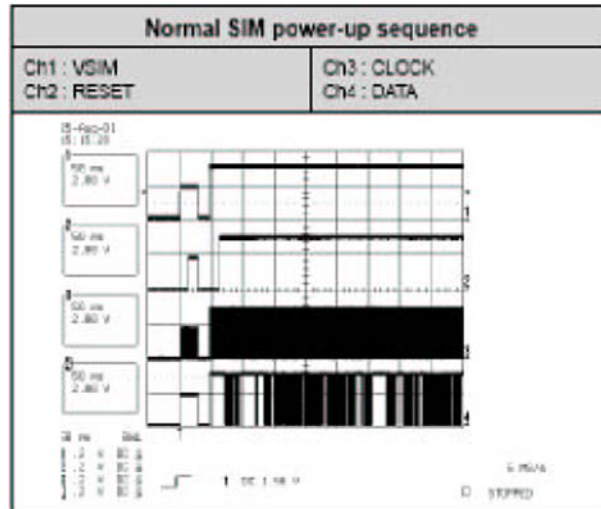

Figure 88 Signal diagram

■ **User interface**

**Blank display**

The display does not show any information at all.

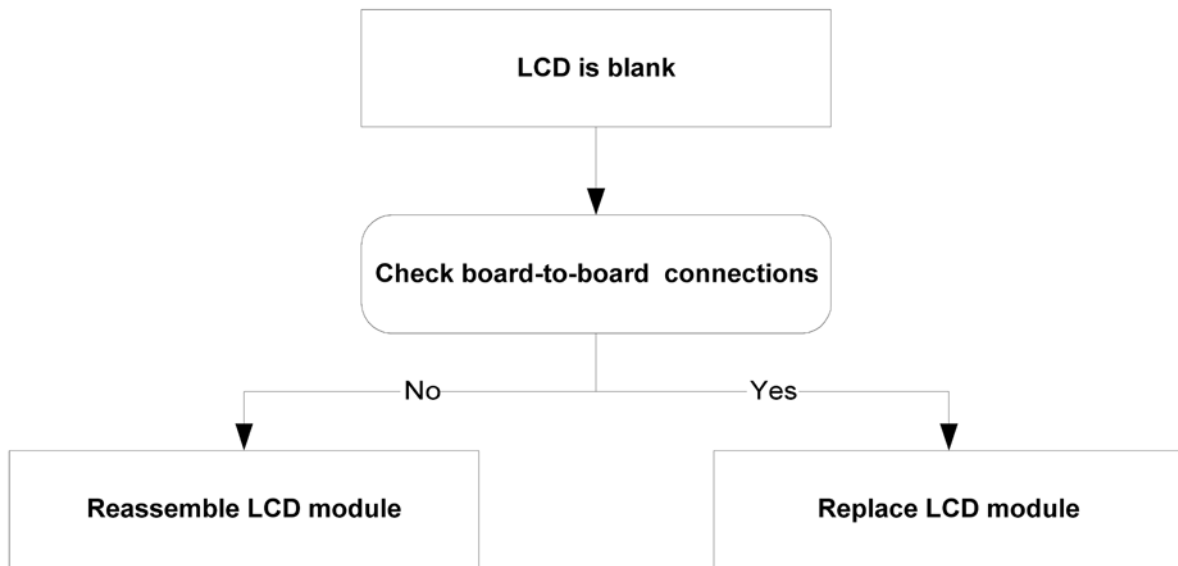

Figure 89 Blank display

**Display is corrupt**

The display contains missing or fading segments or color presentation is incorrect.



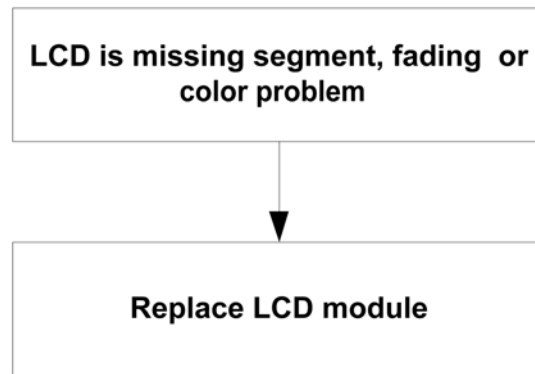

Figure 90 Display is corrupt

### Dead keys

Not a single key is responding.

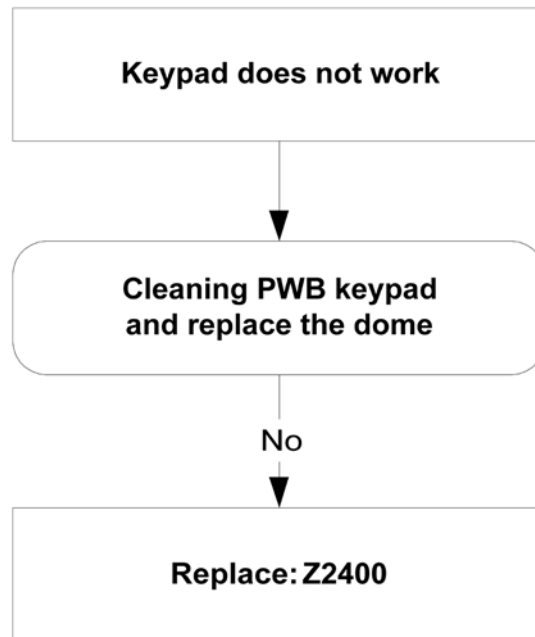

Figure 91 Dead keys

### No backlight for display or keys

There is no backlight on the display or on the keys.

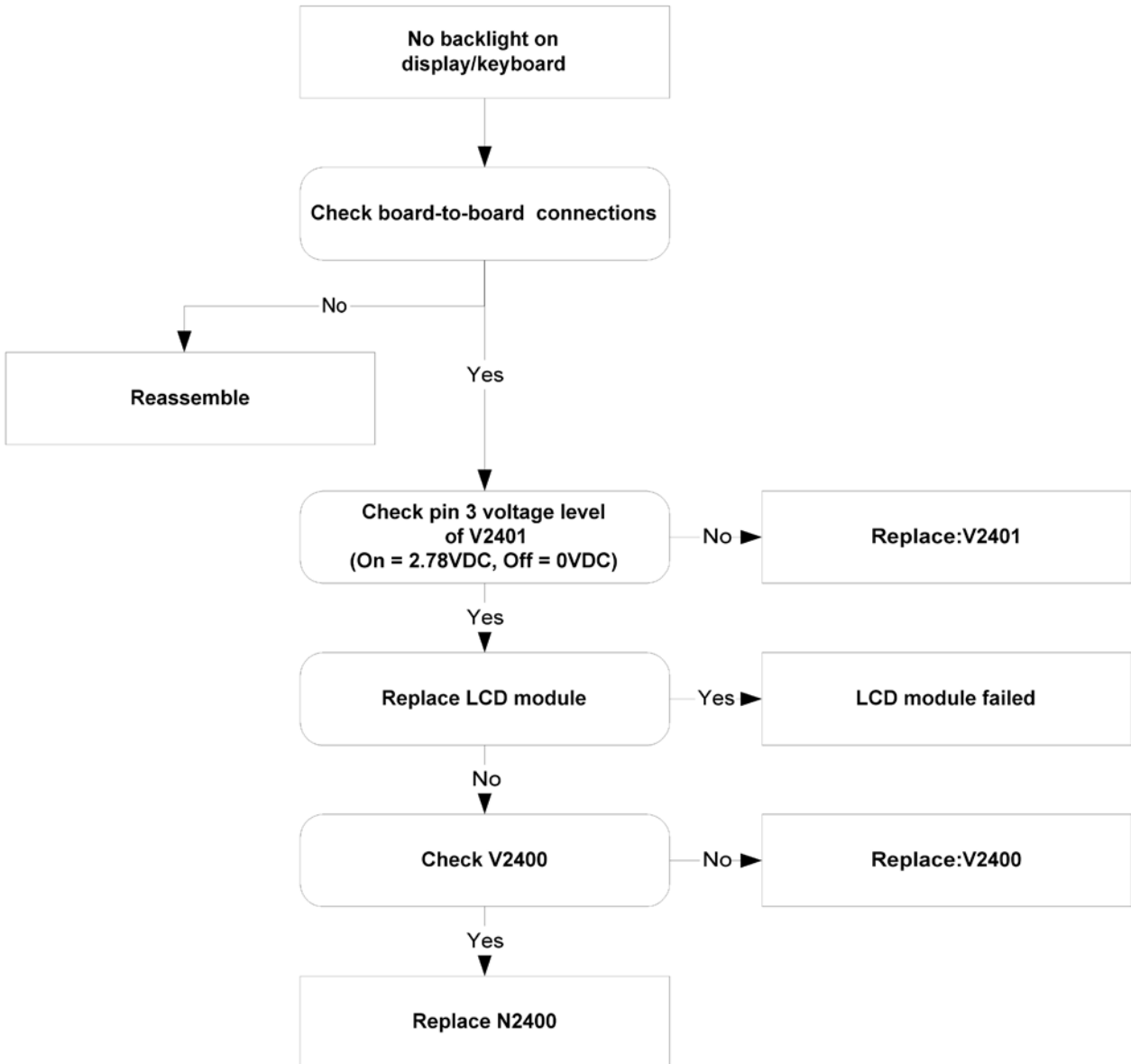

Figure 92 No backlight for display or keys

## ■ Audio troubleshooting

### Audio troubleshooting using phoenix

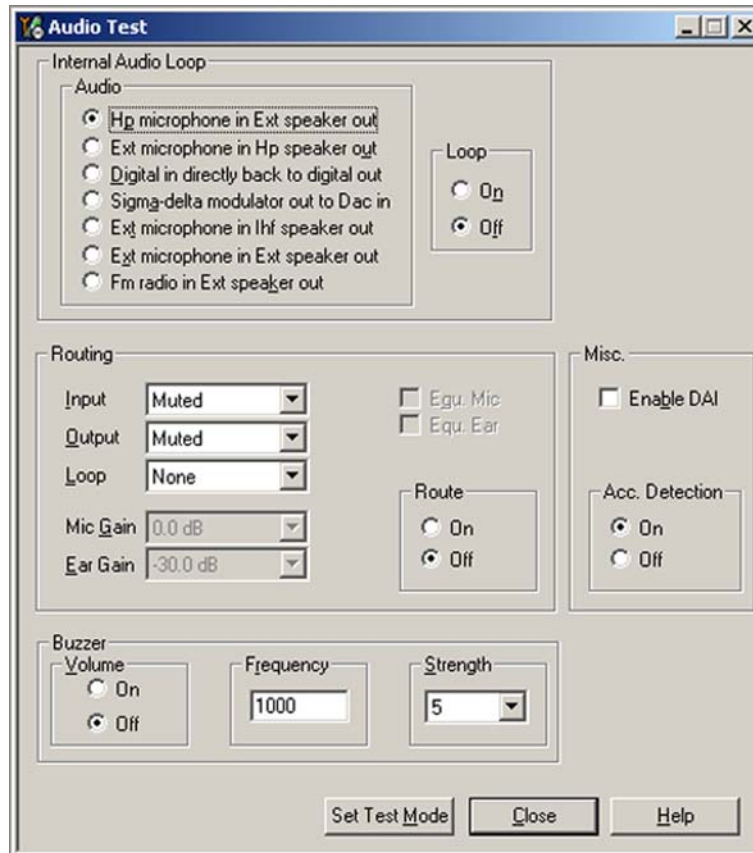

Figure 93 Phoenix audio test window

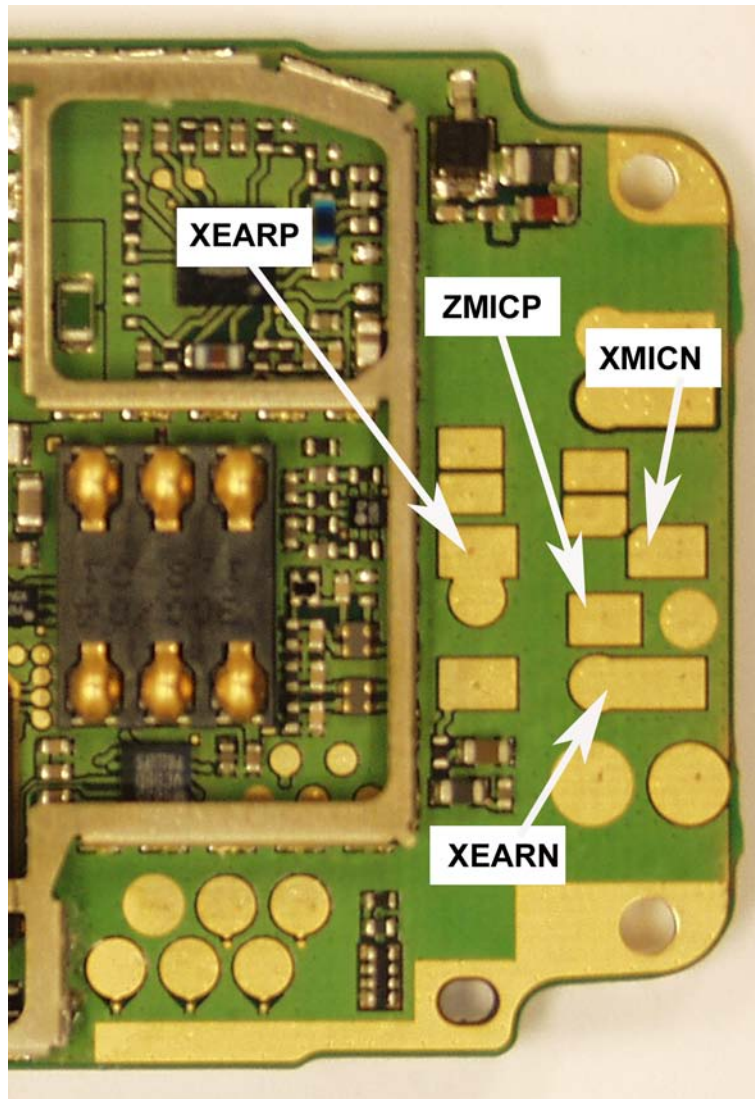

Figure 94 PWB audio test points

### Check microphone using "Hp microphone in Ext speaker out" loop

#### Steps

1. Connect phone with Phoenix.
2. Open "audio test" window from "Testing -> Audio test", as shown in *Figure Phoenix audio test window* above.
3. Select "Hp microphone in Ext speaker out"
4. Select "Loop" as "On"
5. Input sound at microphone port, for example 94 dB SPL 1 kHz.
6. Check if signal is detected at XEARP/N pads, shown in *Figure PWB audio test points* above.

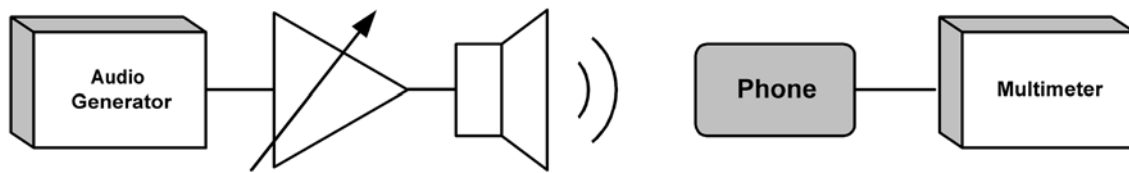

Figure 95 Test arrangement for microphone

### Check earpiece using "Ext microphone in Hp speaker out" loop

#### Steps

1. Connect phone with Phoenix.
2. Open "audio test" window from "Testing -> Audio test", as shown in *Figure Phoenix audio test window* above.
3. Select "Ext microphone in Hp speaker out"
4. Select "Loop" as "On"
5. Input signal to XMICP/N pads, as shown in *Figure PWB audio test points* above, for example 100 mVpp, 1 kHz.
6. Check if sound is heard in earpiece.

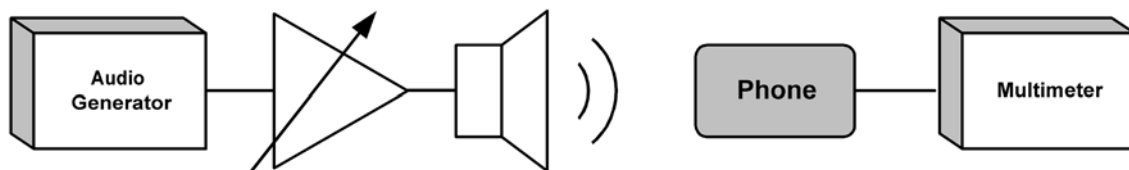

Figure 96 Test arrangement for of earpiece

### Check IHF & ringing tone function using "Buzzer"

#### Steps

1. Connect phone with Phoenix.
2. Open "audio test" window from "Testing -> Audio test", as shown in *Figure Phoenix audio test window* above.
3. In "Buzzer" area, select suitable signal to be played, for example 1 kHz, Strength 5"
4. Select "Volume" as "On"
5. Check if sound is heard in IHF.

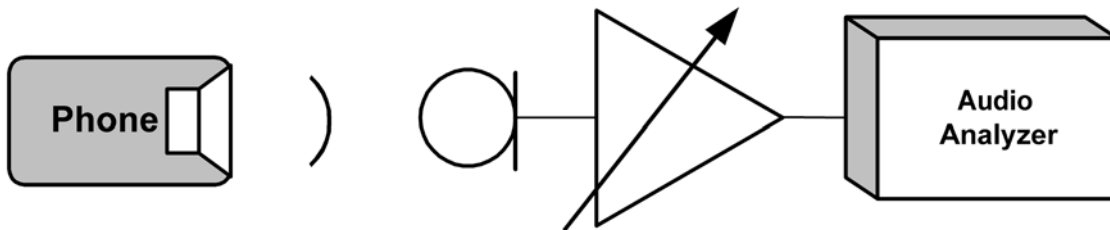

Figure 97 Checking IHF and ring tone by using "Buzzer"

### Check vibra function using "Vibra control"

#### Steps

1. Connect phone with Phoenix.
2. Open "Vibra control" window from "Testing -> Vibra control", as shown in the figure below.
3. Select suitable intensity value, for example 53 %.
4. Select "Vibra state" as "Enabled"
5. Click "Write".
6. Check if Vibra works.

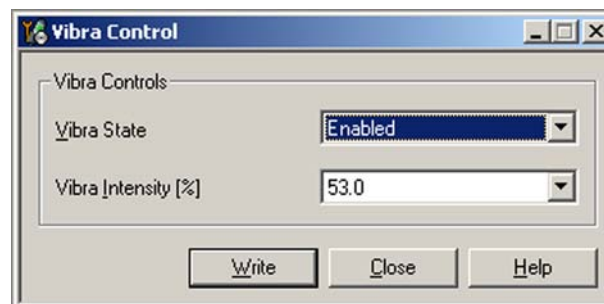

Figure 98 Checking vibra function by using vibra control

**Earpiece fault**

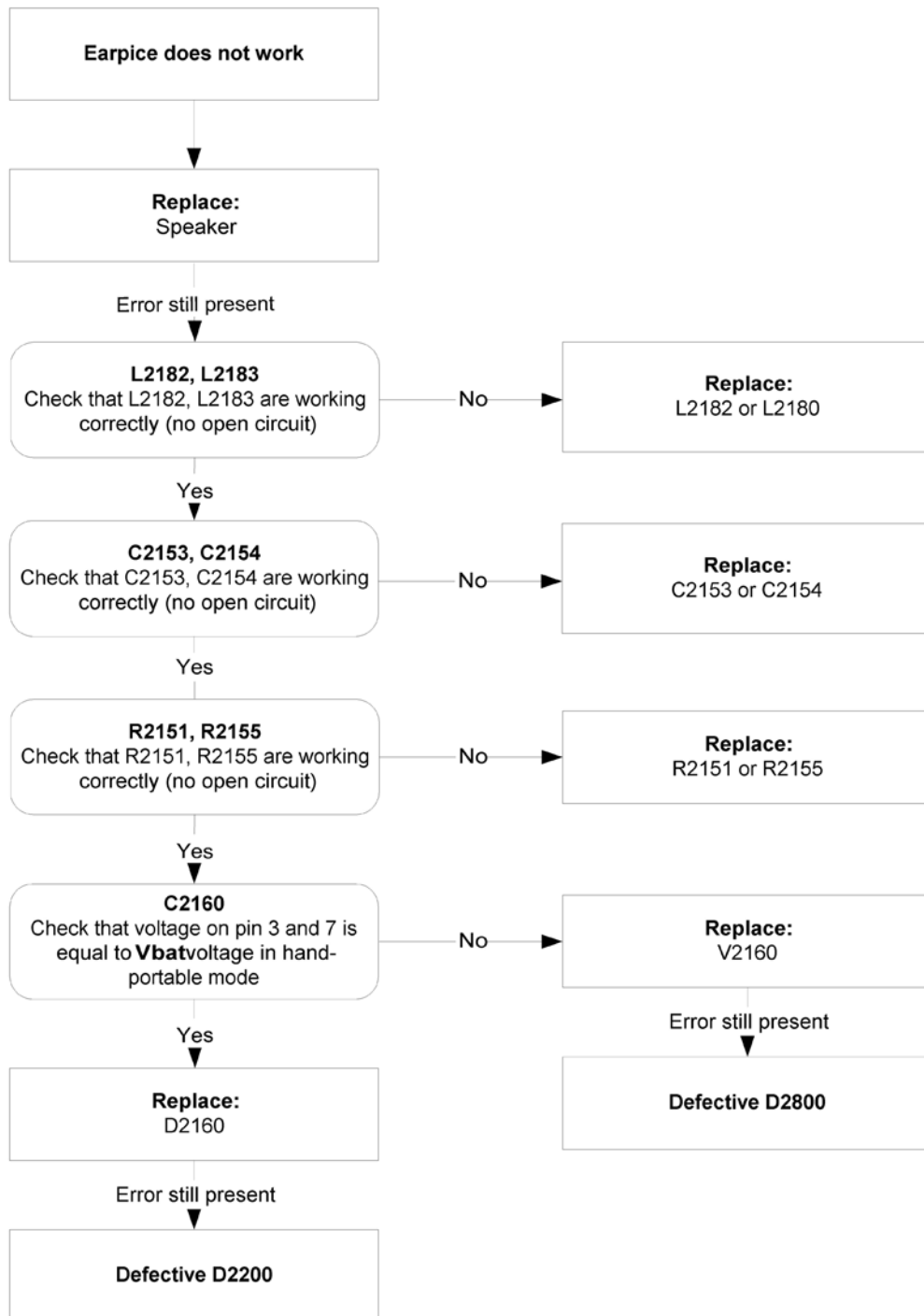

Figure 99 Earpiece fault flow chart

**IHF/ringing tone fault**

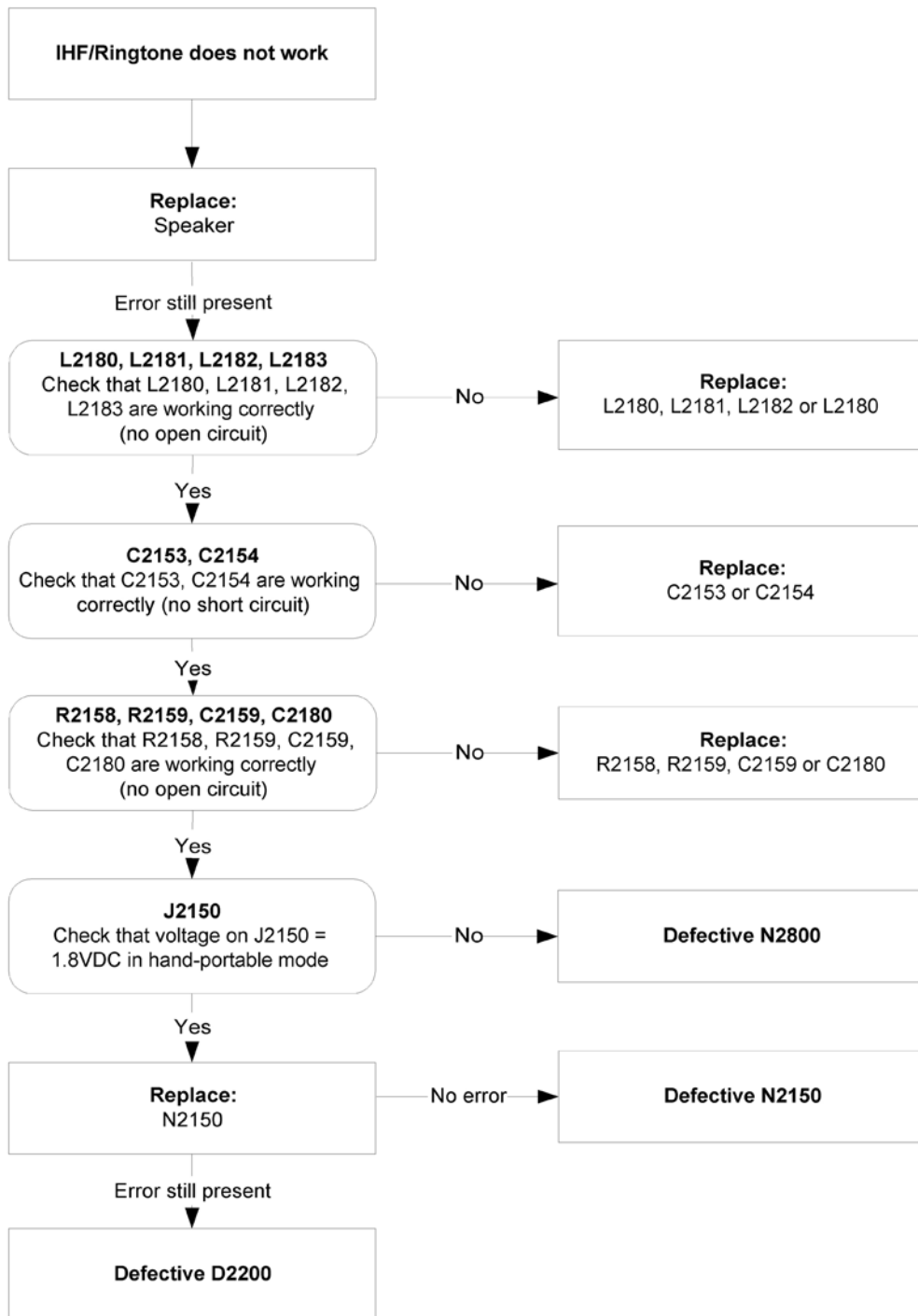

Figure 100 IHF/ringing tone fault flow chart



## Headset earpiece fault

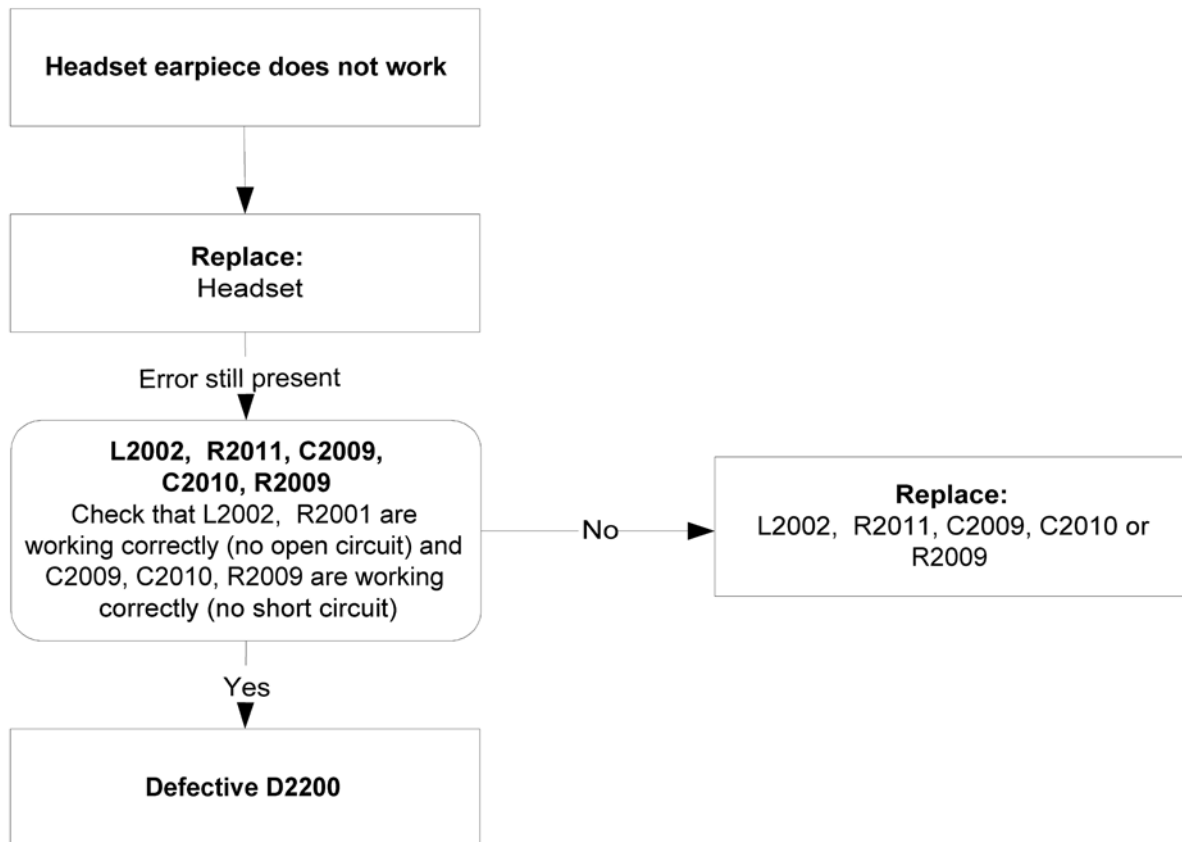

Figure 101 Headset earpiece fault flow chart

**Microphone fault**

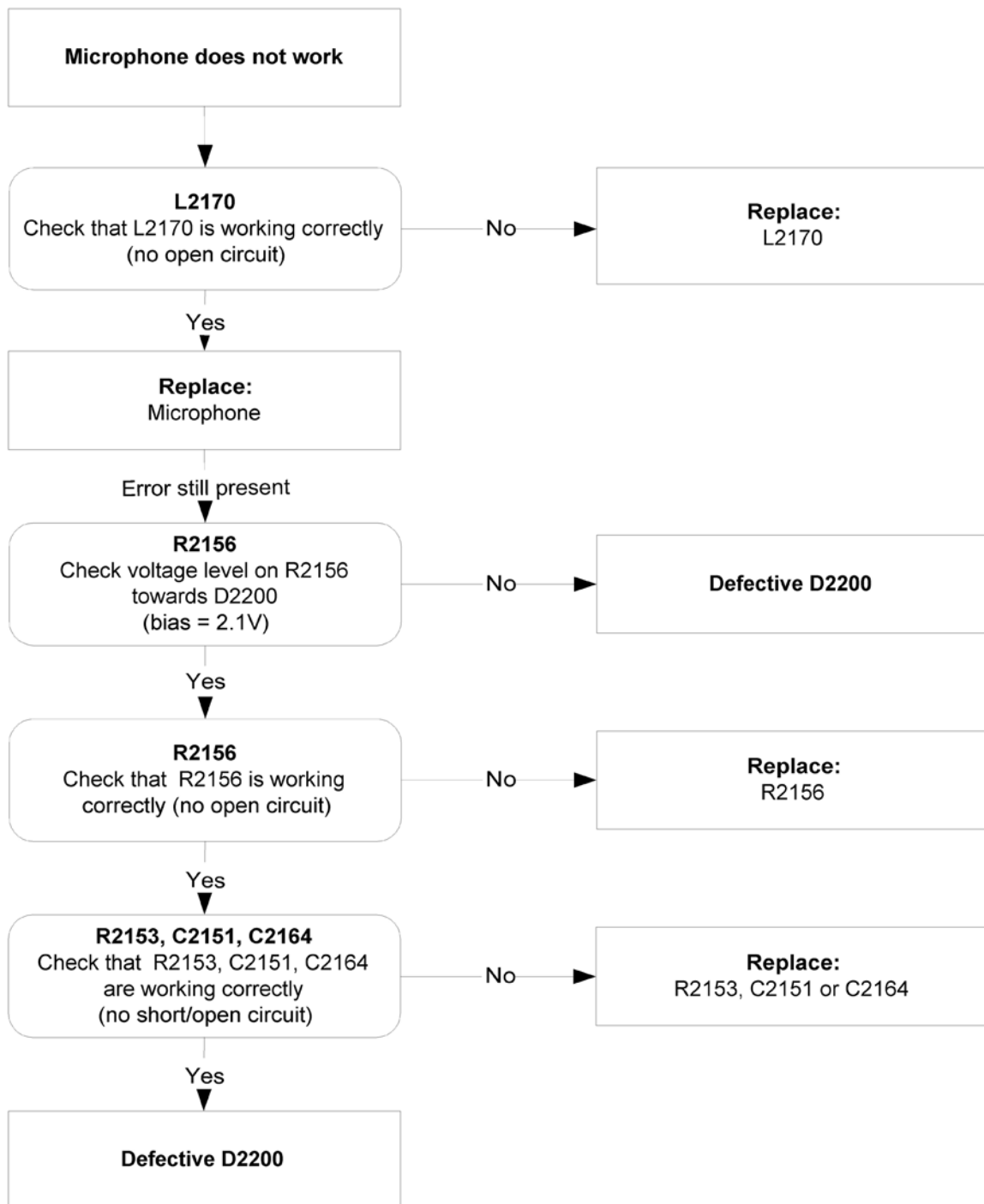

Figure 102 Microphone fault flow chart

## Headset microphone fault

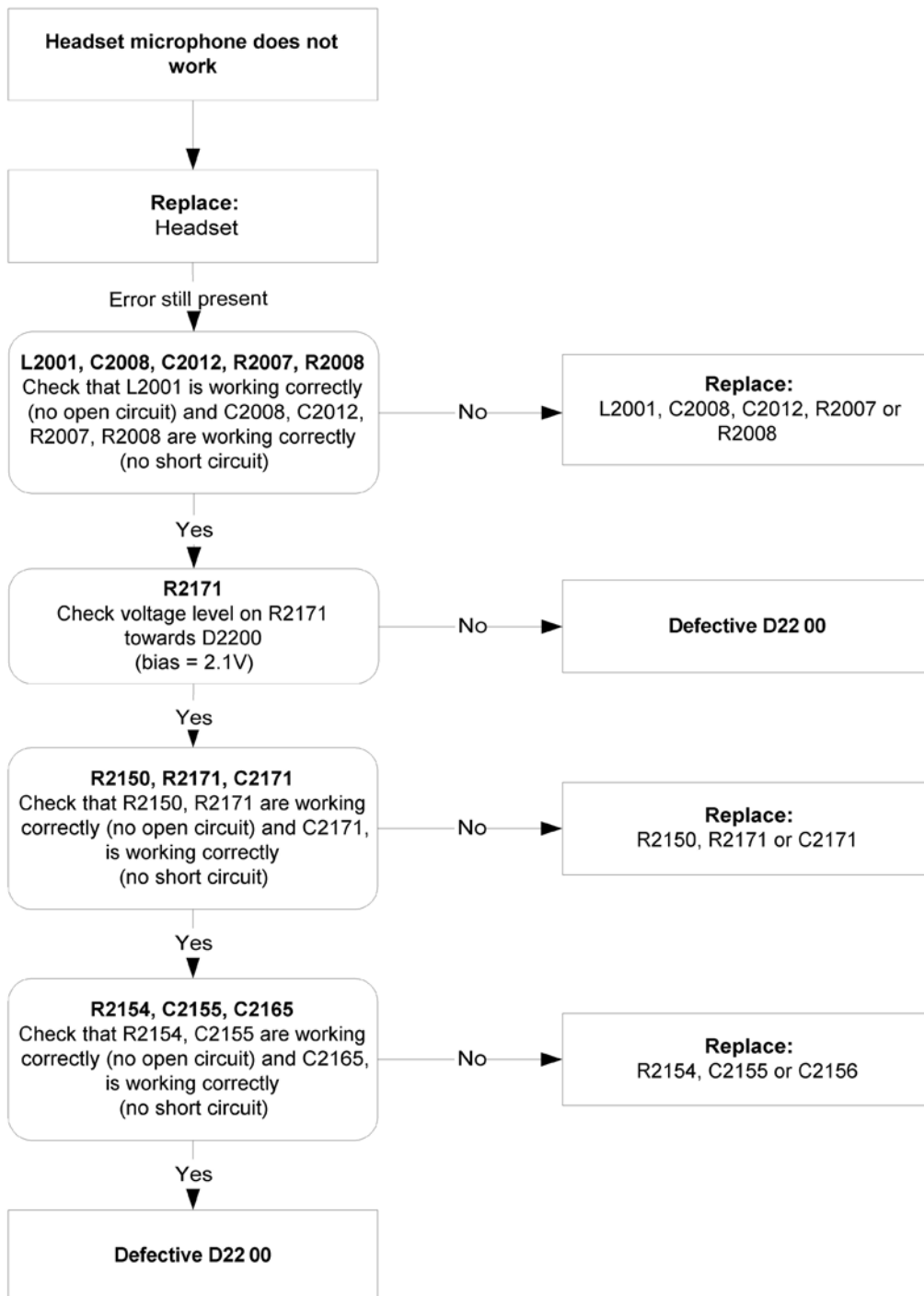

Figure 103 Headset microphone fault flow chart

(This page left intentionally blank.)

## 7 — RF troubleshooting

(This page left intentionally blank.)

## Table of Contents

General RF troubleshooting.....	7-5
General RF troubleshooting.....	7-5
RF key components.....	7-5
Auto tuning.....	7-6
Receiver.....	7-7
General instructions for GSM 900 RX troubleshooting.....	7-7
Troubleshooting diagram for GSM 900 receiver.....	7-9
General instructions for GSM 1800 RX troubleshooting.....	7-10
Troubleshooting diagram for GSM 1800 receiver.....	7-12
Measurement points in the receiver.....	7-13
Transmitter.....	7-14
General instructions for GSM 900 TX troubleshooting.....	7-14
Troubleshooting diagram for GSM 900 transmitter.....	7-16
GSM 900 TX output power.....	7-18
General instructions for GSM 1800 TX troubleshooting.....	7-21
Troubleshooting diagram for GSM 1800 transmitter.....	7-23
GSM 1800 TX output power.....	7-25
Synthesizer troubleshooting .....	7-28
Introduction.....	7-28

## List of Figures

Figure 104 RF key components on PWB.....	7-5
Figure 105 Supply points at UEM (D2200).....	7-6
Figure 106 Supply point at RF IC (N7600).....	7-6
Figure 107 Auto tuning concept with CMU200.....	7-7
Figure 108 Auto tuning concept with RX and TX tuning devices and splitter.....	7-7
Figure 109 GSM 900 RF controls window.....	7-8
Figure 110 GSM 900 Receiver troubleshooting.....	7-9
Figure 111 900 RX I/Q signal waveform.....	7-10
Figure 112 GSM 1800 RF controls window.....	7-11
Figure 113 GSM 1800 Receiver troubleshooting.....	7-12
Figure 114 1800 RX I/Q signal waveform.....	7-13
Figure 115 RX measurements point of the control voltages to FEM N7700.....	7-13
Figure 116 Measurement points at the RX SAW Filters – Z7600/Z7602.....	7-14
Figure 117 RX I/Q signals.....	7-14
Figure 118 GSM 900 RF controls window.....	7-15
Figure 119 GSM 900 transmitter troubleshooting.....	7-16
Figure 120 TX I/O signal.....	7-17
Figure 121 VC1, VC3 signals.....	7-17
Figure 122 TXP signal.....	7-18
Figure 123 TXC signals at PCL5.....	7-18
Figure 124 TX I/O signal.....	7-19
Figure 125 VC1, VC3 signals.....	7-19
Figure 126 TXP signal.....	7-20
Figure 127 TXC signals at PCL5.....	7-20
Figure 128 TXC signals at PCL19.....	7-21
Figure 129 GSM 1800 RF controls window.....	7-22
Figure 130 GSM 1800 transmitter troubleshooting.....	7-23
Figure 131 TX I/O signal.....	7-24

---

Figure 132 VC1, VC2, VC3 signals.....	7-24
Figure 133 TXP signal.....	7-25
Figure 134 TXC signals at PCL0.....	7-25
Figure 135 TX I/O signal.....	7-26
Figure 136 VC1, VC2, VC3 signals.....	7-26
Figure 137 TXP signal.....	7-27
Figure 138 TXC signals at PCL0.....	7-27
Figure 139 TXC signals at PCL15.....	7-28
Figure 140 PLL Troubleshooting diagram.....	7-29
Figure 141 VCX0 26 MHz waveform.....	7-30
Figure 142 Measurement point for VCX0.....	7-30



## ■ General RF troubleshooting

### General RF troubleshooting

#### Most RF semiconductors are static discharge sensitive

Two types of measurements are used in the following. It will be specified if the measurement type is "RF" or "LF".

- RF measurements are done with a Spectrum Analyzer and a high-frequency 500 ohm passive probe, for example HP54006A. (Note that when measuring with the 500 ohm probe the signal will be around 20 dB attenuated. The values in the following will have these 20 dB subtracted and represent the real value seen on the spectrum analyzer). Note that the testing have some losses which must be taken into consideration when calibrating the test system.
- LF (Low frequency) and DC measurements should be done with a 10:1 probe and an oscilloscope. The probe used in the following is 10 Mohm/8pF passive probe. If using another probe then bear in mind that the voltages displayed may be slightly different. Always make sure the measurement set-up is calibrated when measuring RF parameters on the antenna pad. Remember to include the loss in the module repair jig when realigning the phone.

So ESD protection must be applied during repair (ground straps and ESD soldering irons). RF IC N7600 and FEM are moisture sensitive so parts must be pre-baked prior to soldering. Apart from key-components described in this document there are a lot of discrete components (resistors, inductors and capacitors) for which troubleshooting is done by checking if soldering of the component is done properly and checking if the component is missing from PWB. Capacitors can be checked for short-circuiting and resistors for value by means of an ohmmeter, but be aware in-circuit measurements should be evaluated carefully. In the following both the name EGSM and GSM 850 will be used for the lower band and both PCN and GSM 1900 will be used for the upper band.

### RF key components

Figure 104 RF key components on PWB

N7600	RF IC
N7700	FEM (PA and antenna switch)
Z7602	EGSM 850/900 RX SAW filter
Z7600	DCS 1800/PCS1900 RX SAW filter
Z7603	EGSM 850/900 TX filter
Z7604	DCS 1800/PCS1900 TX filter
B7600	26 MHz crystal

Refer to the picture below for measuring points at the UEM (D2200).

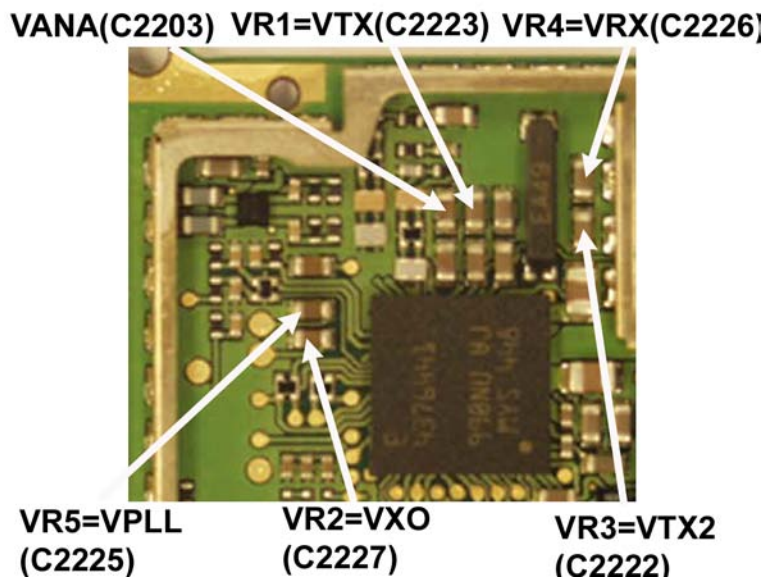

Figure 105 Supply points at UEM (D2200)

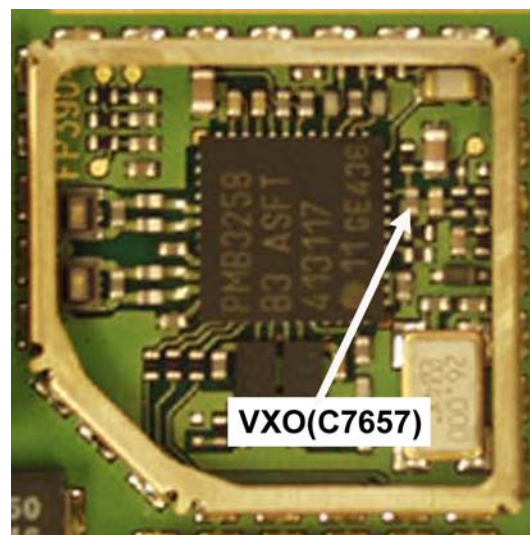

Figure 106 Supply point at RF IC (N7600)

## ■ Auto tuning

### Context

This phone can be tuned automatically. Autotune is designed to align the phone's RF part easier and faster. It performs calibrations, tunings and measurements of RX and TX. The results are displayed and logged in a result file, if initiated.

Hardware requirements for auto tuning:

- PC (Windows 2000/NT) with GPIB card
- Power supply
- Product specific module jig
- Cables: 3 (alt.1) RF cable, 1 GPIB cable and DAU-9S
- Signal analyser (TX), signal generator (RX) and RF-splitter *or* one device including all.

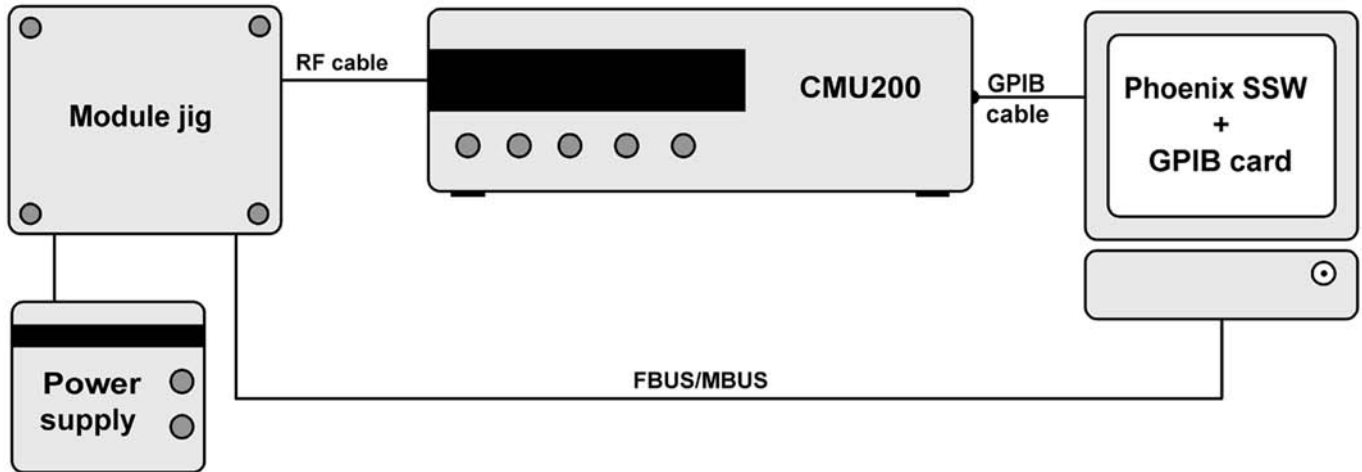

Figure 107 Auto tuning concept with CMU200

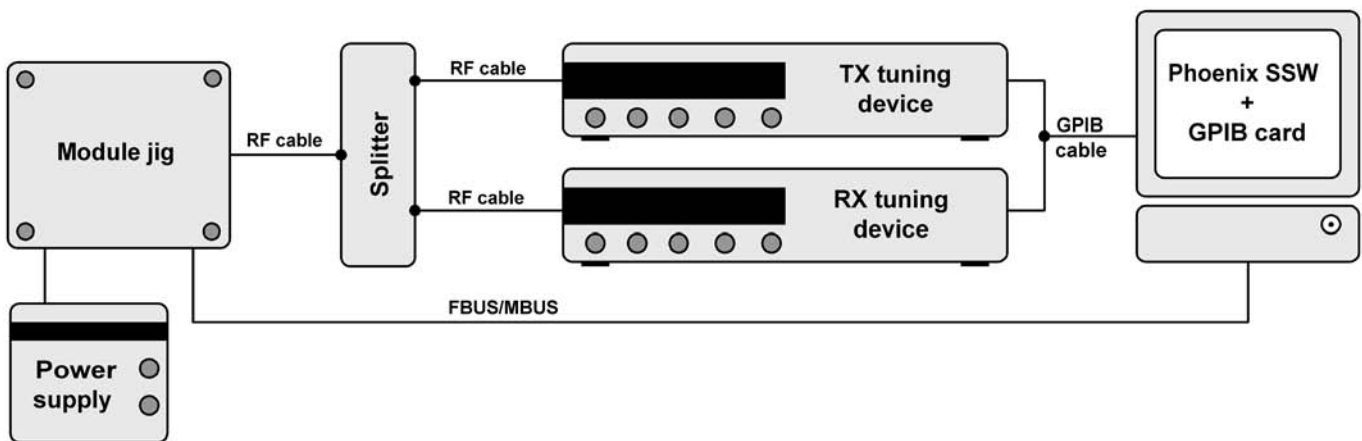

Figure 108 Auto tuning concept with RX and TX tuning devices and splitter

Copy the two phone specific ini-files, for example *rm\_13\_tunings.ini* and *autotune\_RM-13.ini*, to a phone specific folder, for example `|Phoenix|products|RM-13|`.

## Steps

1. Make sure the phone (in the jig) is connected to the equipment. Else, some menus will not be shown in Phoenix.
2. The first time you are using automatic tuning on this phone model, on this computer, you will have to *Set loss* for cables and jigs.
3. To go to autotune, select *Tuning (Alt-U) > Auto-Tune (Alt-A)* from the menu.
4. If you need more assistance, please refer to the *Phoenix Help*.

## ■ Receiver

### General instructions for GSM 900 RX troubleshooting

## Steps

1. Connect the phone to a PC with the module repair jig.
2. Start *Phoenix* and establish a connection to the phone with the data cable e.g. FBUS.
3. Select File and Scan product.

4. Wait a while for the PC to read the information from the phone.
5. Select Testing and RF Controls.
6. Set the parameters as follows:
  - i Active Unit: RX
  - ii Band: GSM 900
  - iii Operation Mode: Continuous mode
  - iv RX/TX Channel 37
  - v AGC: 8: FEG\_ON + DTOS\_ON+BB\_6=Vgain\_36
7. The setup should now look like this:

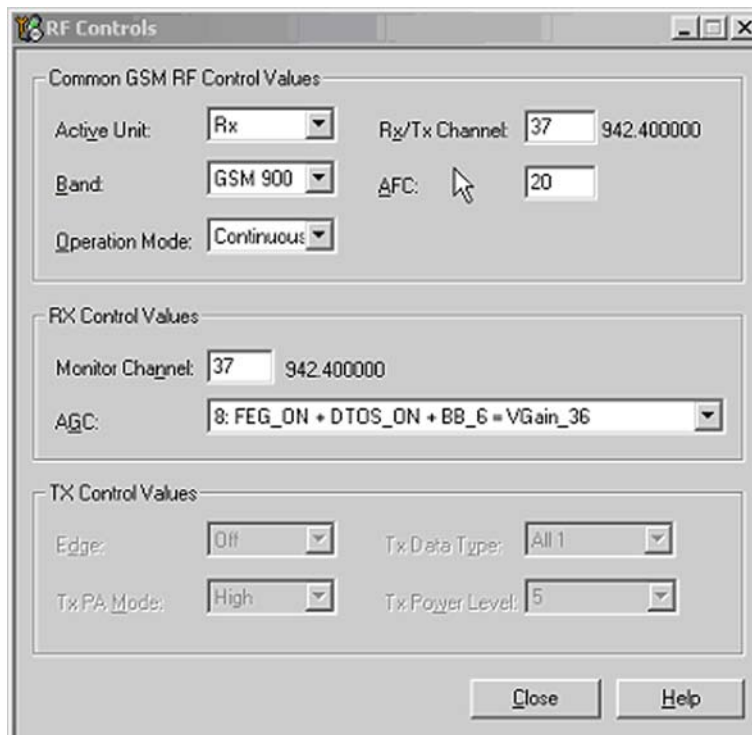

Figure 109 GSM 900 RF controls window

**Troubleshooting diagram for GSM 900 receiver**

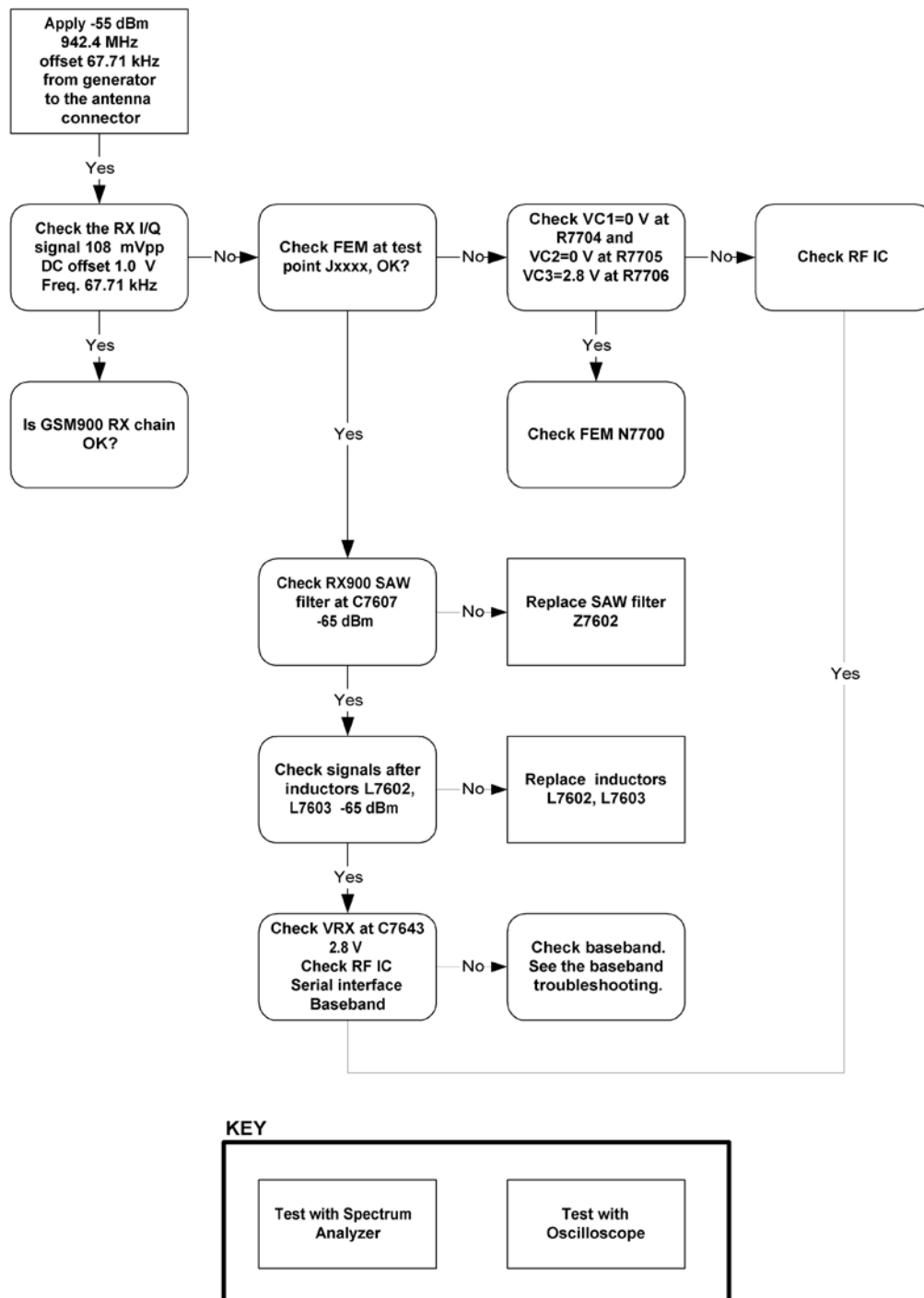

Figure 110 GSM 900 Receiver troubleshooting

By measuring with an oscilloscope at RXIP or RXQP on a working GSM900 receiver this picture should be seen. Signal amplitude 114mVp-p. DC offset 1.0V.

## Results

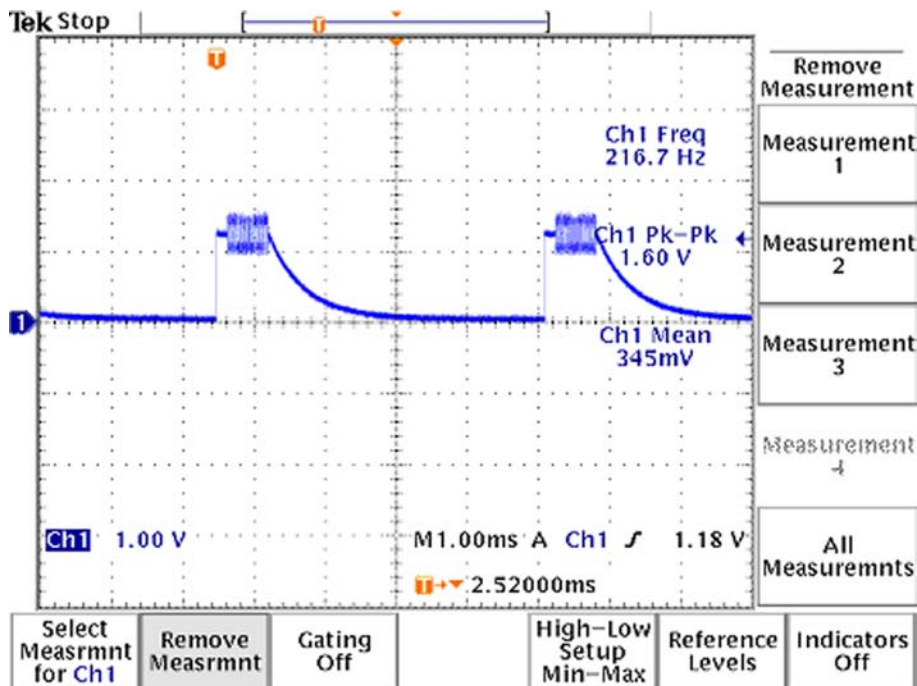

Figure 111 900 RX I/Q signal waveform

## General instructions for GSM 1800 RX troubleshooting

### Steps

1. Connect the phone to a PC with the module repair jig.
2. Start *Phoenix* and establish a connection to the phone with the data cable e.g. FBUS.
3. Select File and Scan product.
4. Wait a while for the PC to read the information from the phone.
5. Select Testing and RF Controls.
6. Set the parameters as follows:
  - i Active Unit: RX
  - ii Band: GSM 1800
  - iii Operation Mode: Continuous mode
  - iv RX/TX Channel 700
  - v AGC: 8: FEG\_ON + DTOS\_ON+BB\_6=Vgain\_36

7. The setup should now look like this:

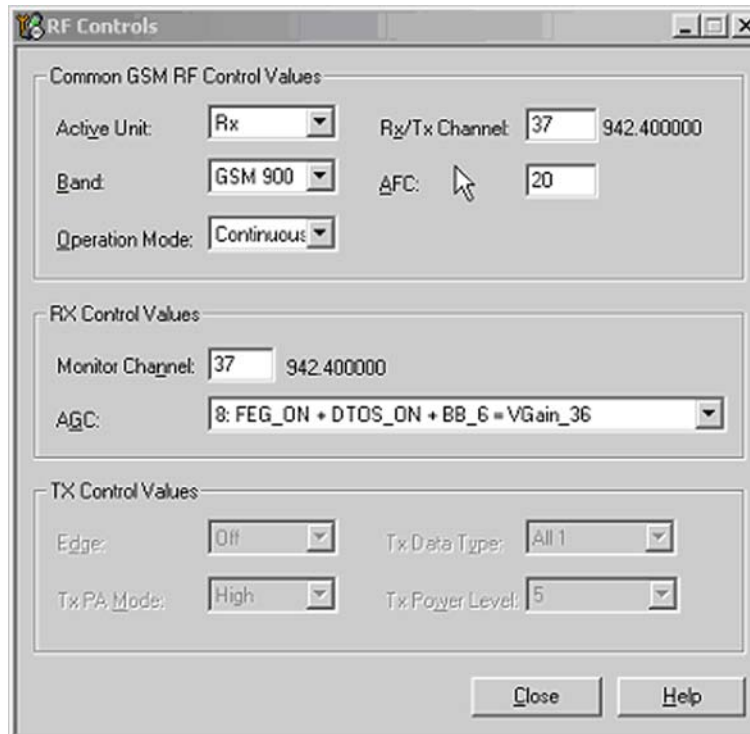

Figure 112 GSM 1800 RF controls window

**Troubleshooting diagram for GSM 1800 receiver**

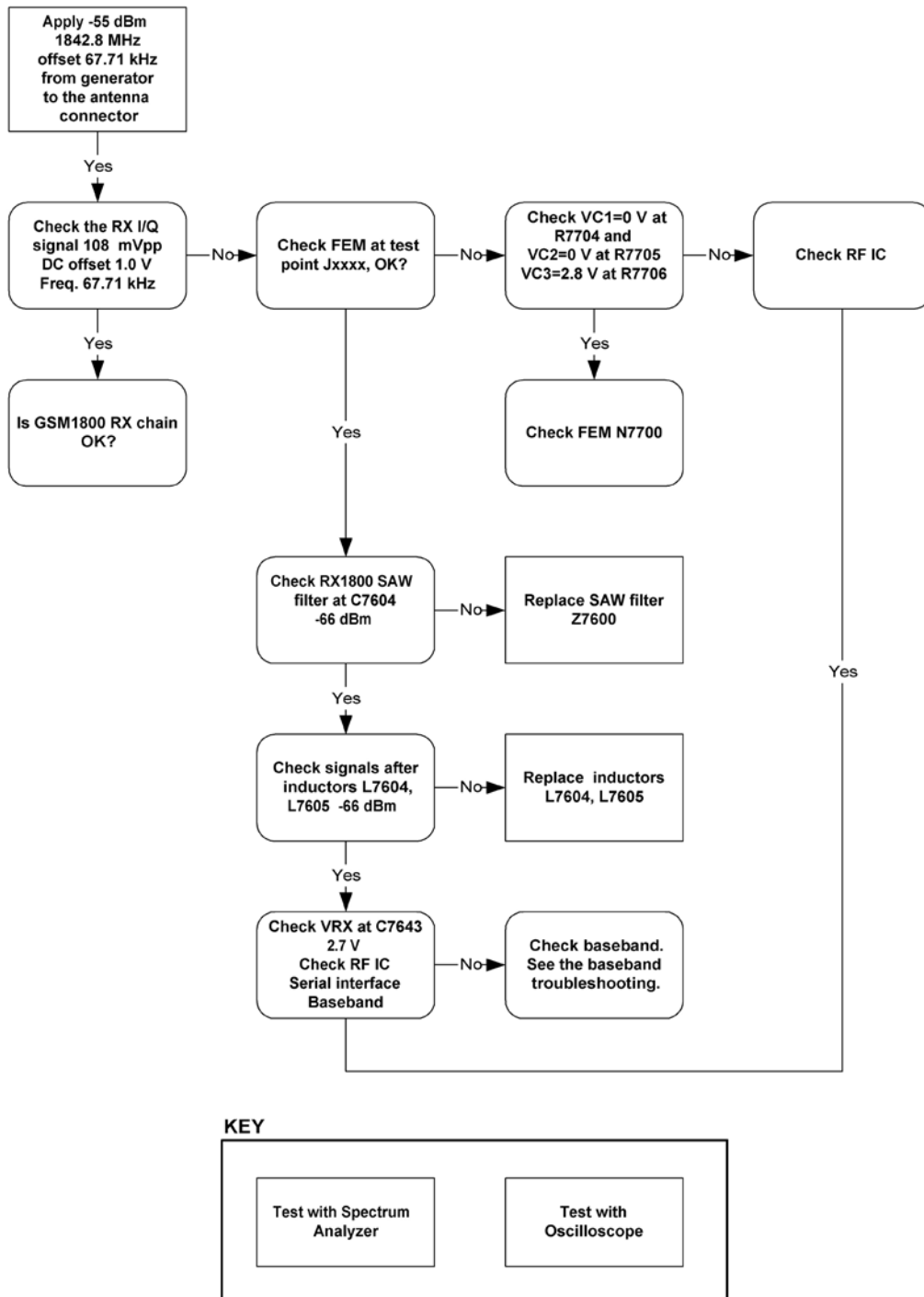

Figure 113 GSM 1800 Receiver troubleshooting

By measuring with an oscilloscope at RXIP or RXQP on a working GSM1800 receiver this picture should be seen. Signal amplitude 114mVp-p. DC offset 1.0V.



## Results

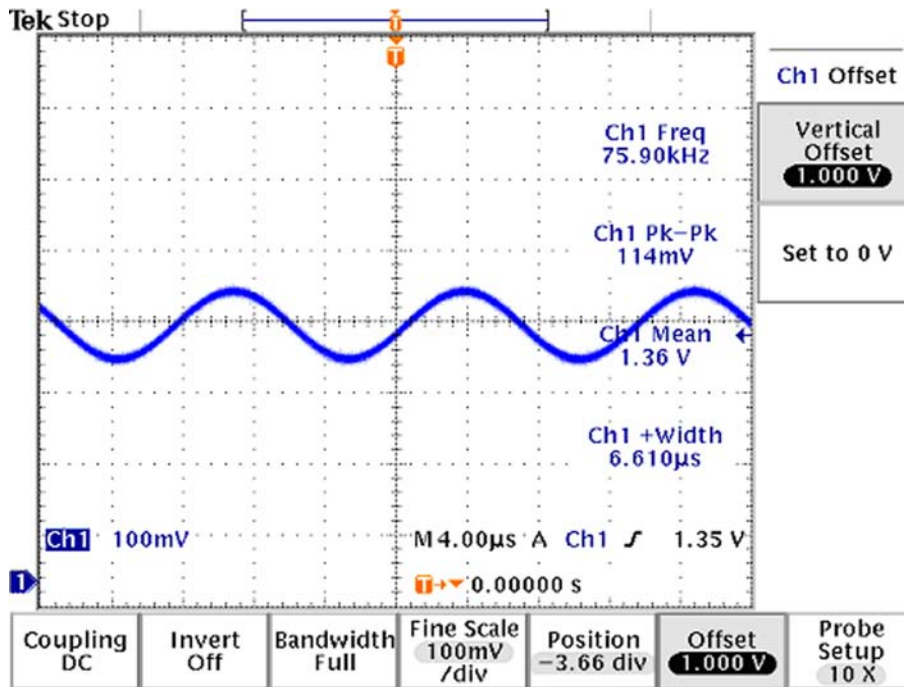

Figure 114 1800 RX I/Q signal waveform

## Measurement points in the receiver

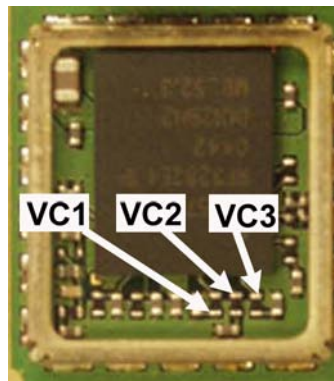

Figure 115 RX measurements point of the control voltages to FEM N7700

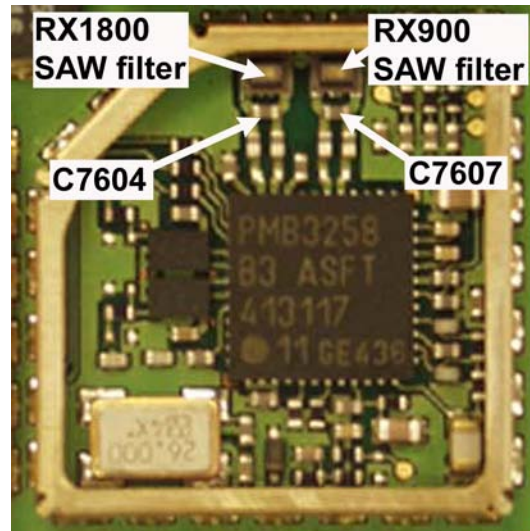

Figure 116 Measurement points at the RX SAW Filters – Z7600/Z7602

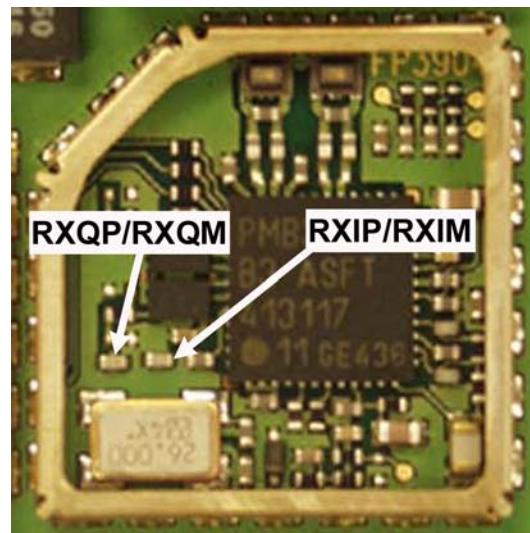

Figure 117 RX I/Q signals

## ■ Transmitter

### General instructions for GSM 900 TX troubleshooting

#### Steps

1. Apply a RF-cable to the RF-connector to allow the transmitted signal act as normal. RF-cable should be connected to an attenuator at least 10dB before connected to the measurement equipment, otherwise the PA may be damaged.
2. Start *Phoenix* and establish a connection to the phone with the data cable e.g. FBUS.
3. Select File and Scan product.
4. Wait a while for the PC to read the information from the phone.
5. Select Testing and RF Controls.
6. Set the parameters as follows:
  - i Band: GSM 900

- ii Active Unit: RX
  - iii TX Power Level: 5
  - iv TX Data Type: Random
7. The setup should now look like this:

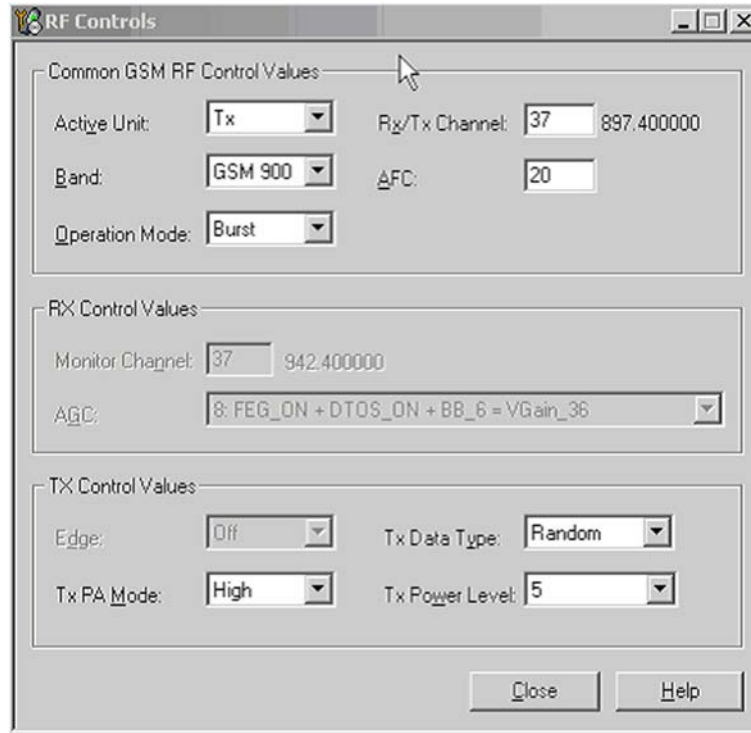

Figure 118 GSM 900 RF controls window

**Troubleshooting diagram for GSM 900 transmitter**

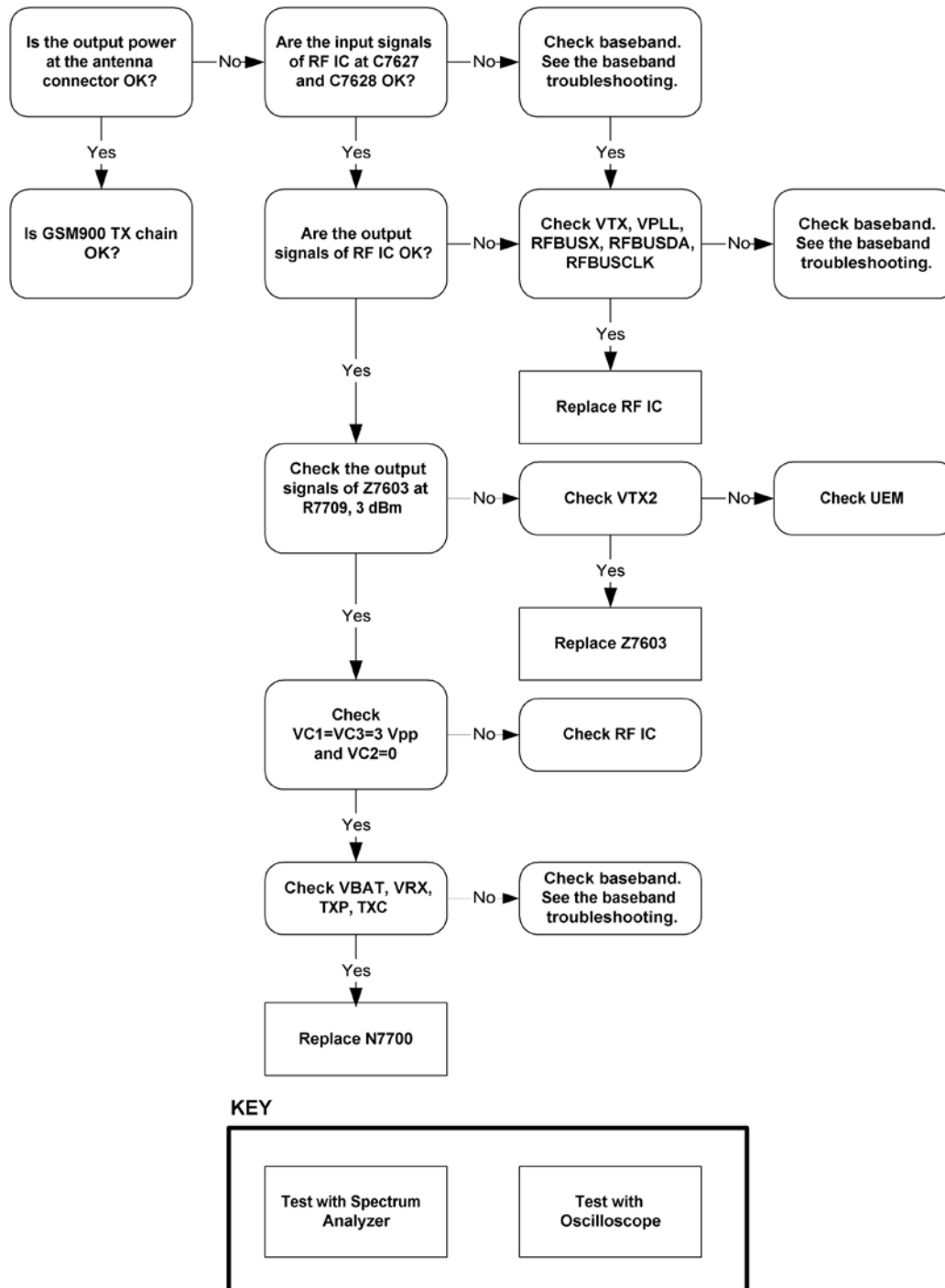

Figure 119 GSM 900 transmitter troubleshooting

Measure the output power of the phone; it should be about 32.5dBm. Remember the cable loss is about 0.3dB.

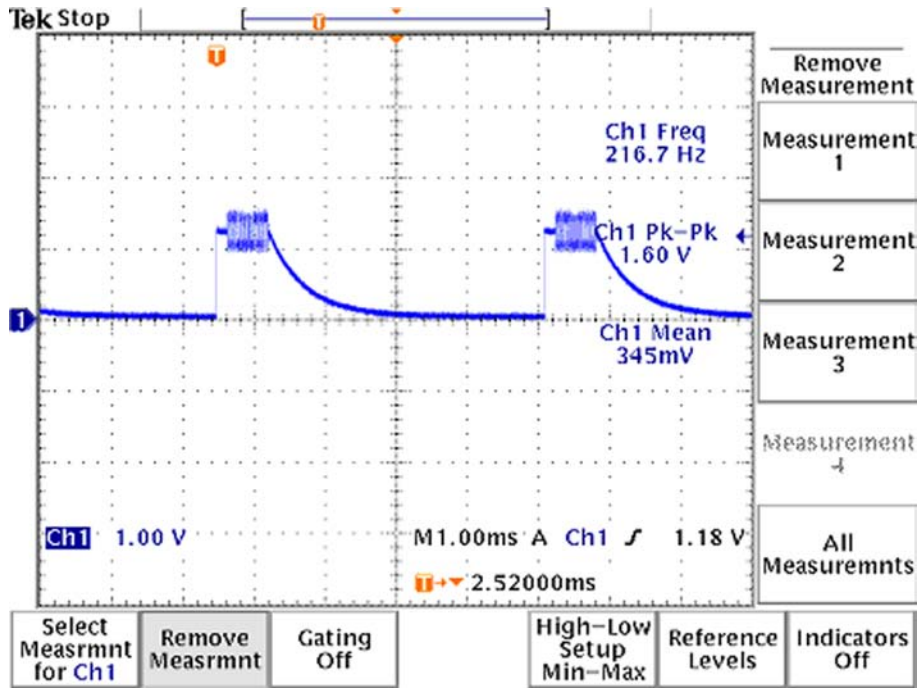

Figure 120 TX I/O signal

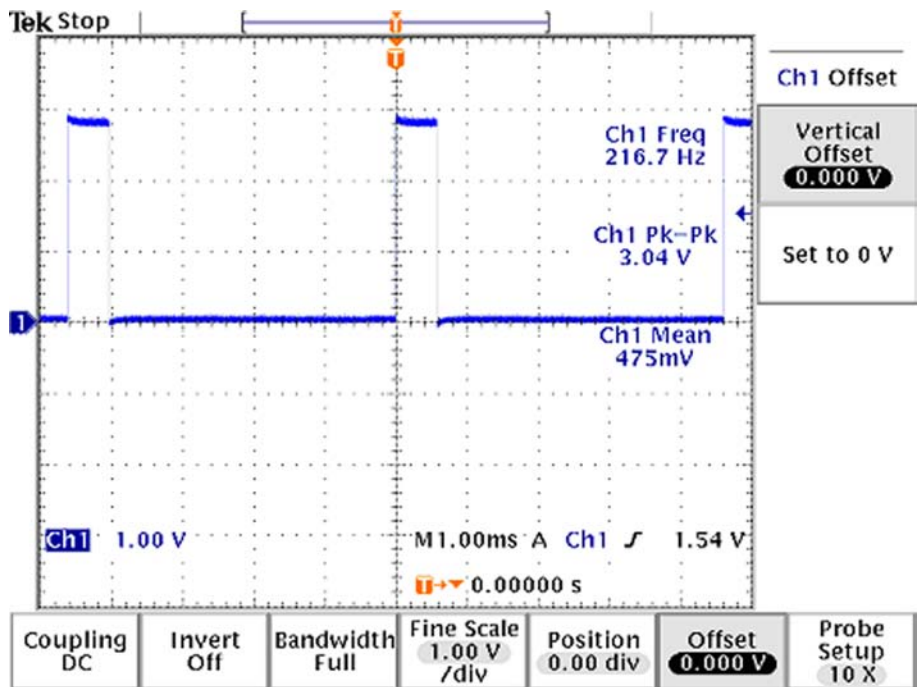

Figure 121 VC1, VC3 signals

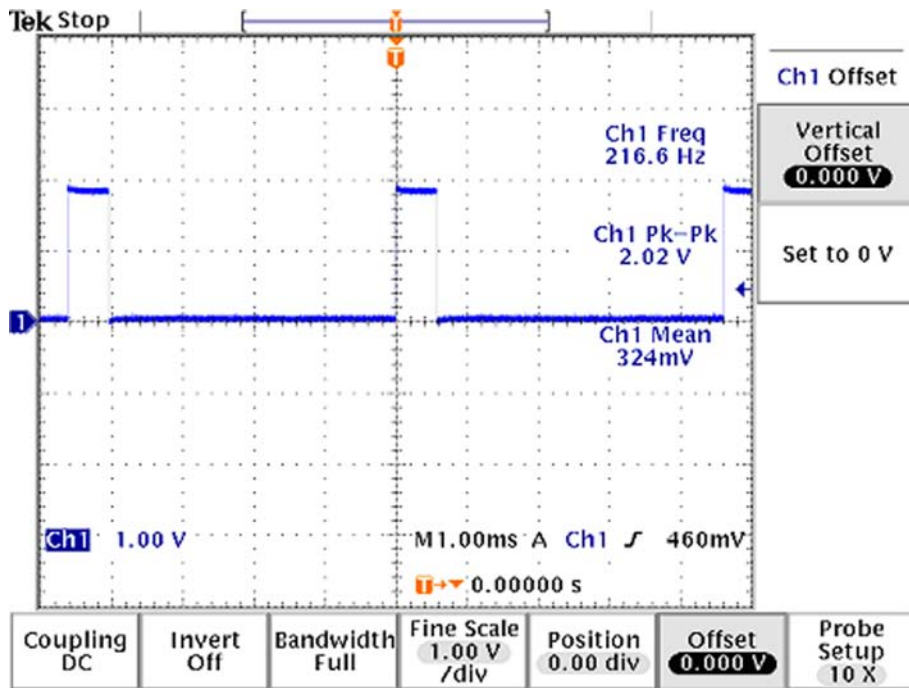

Figure 122 TXP signal

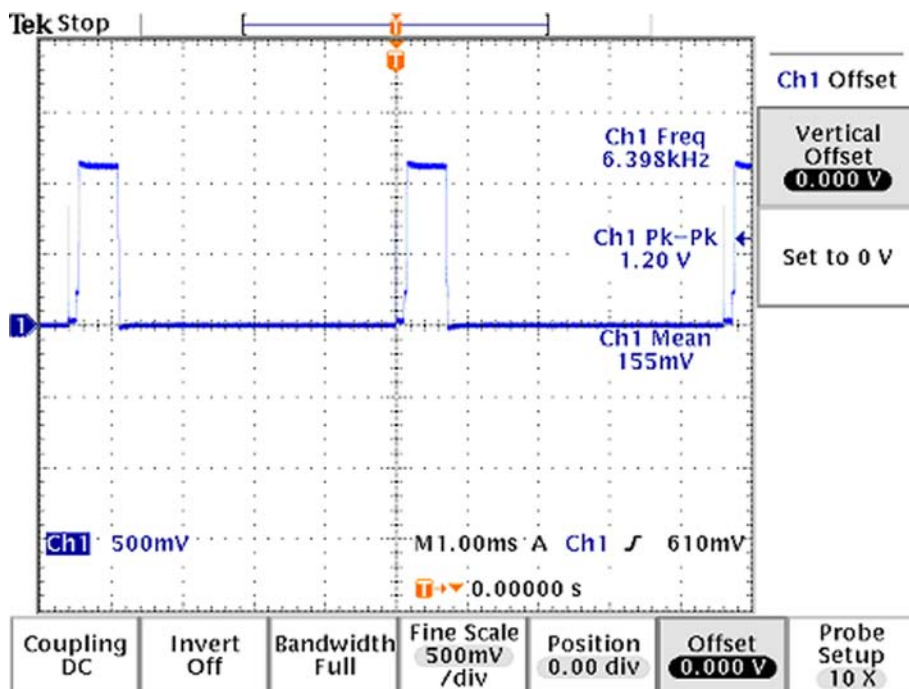

Figure 123 TXC signals at PCL5

### GSM 900 TX output power

Measure the output power of the phone; it should be about 32.5 dBm. Remember the cable loss is about 0.3 dB.



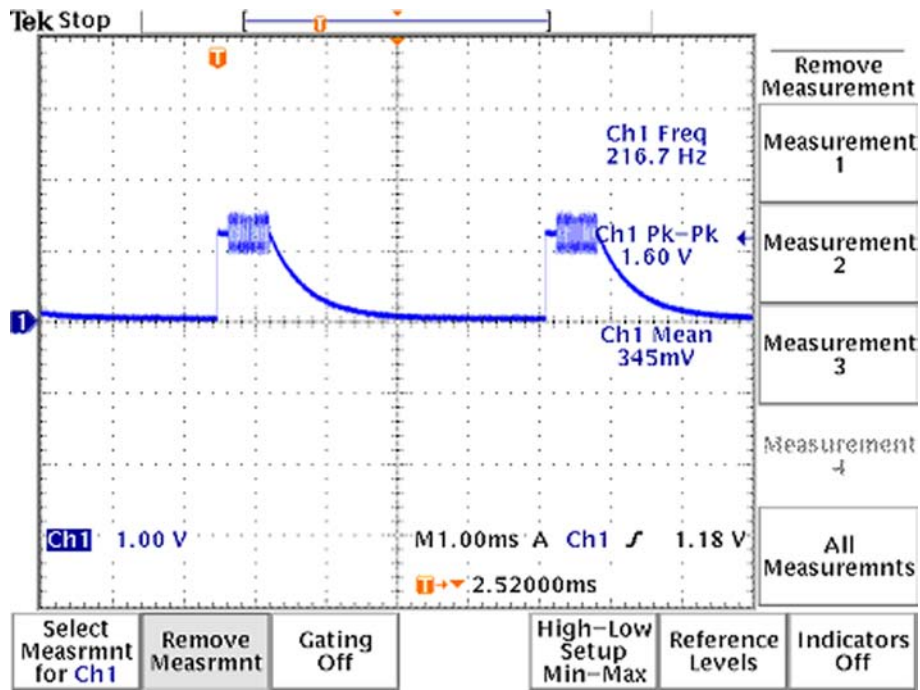

Figure 124 TX I/O signal

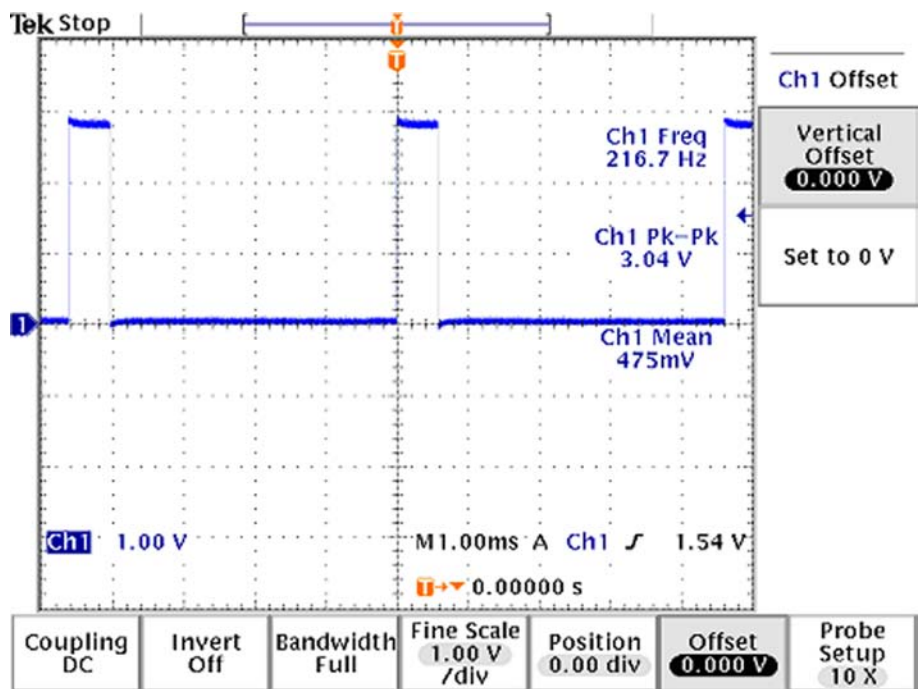

Figure 125 VC1, VC3 signals

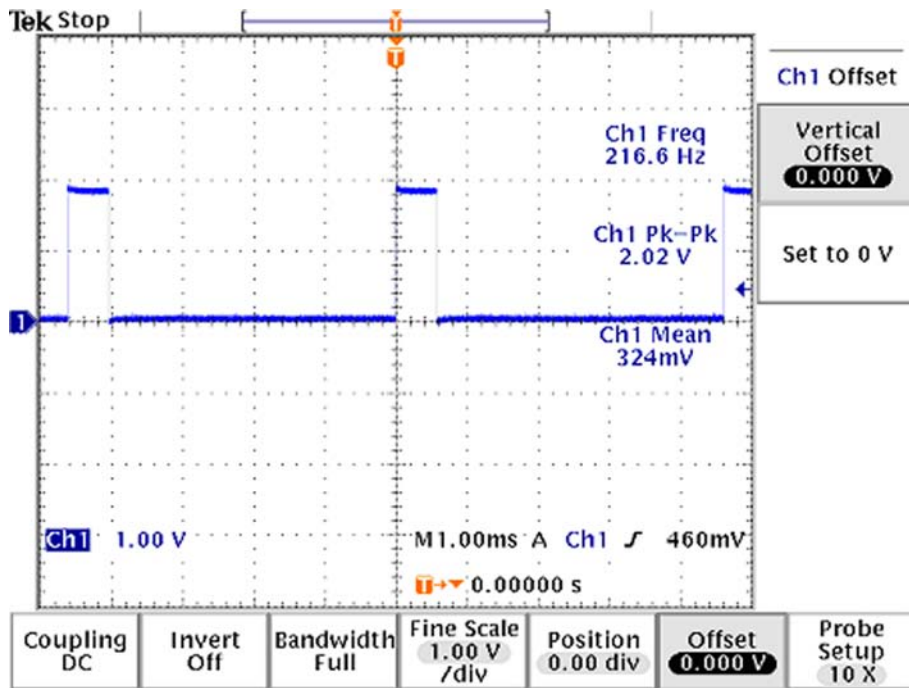

Figure 126 TXP signal

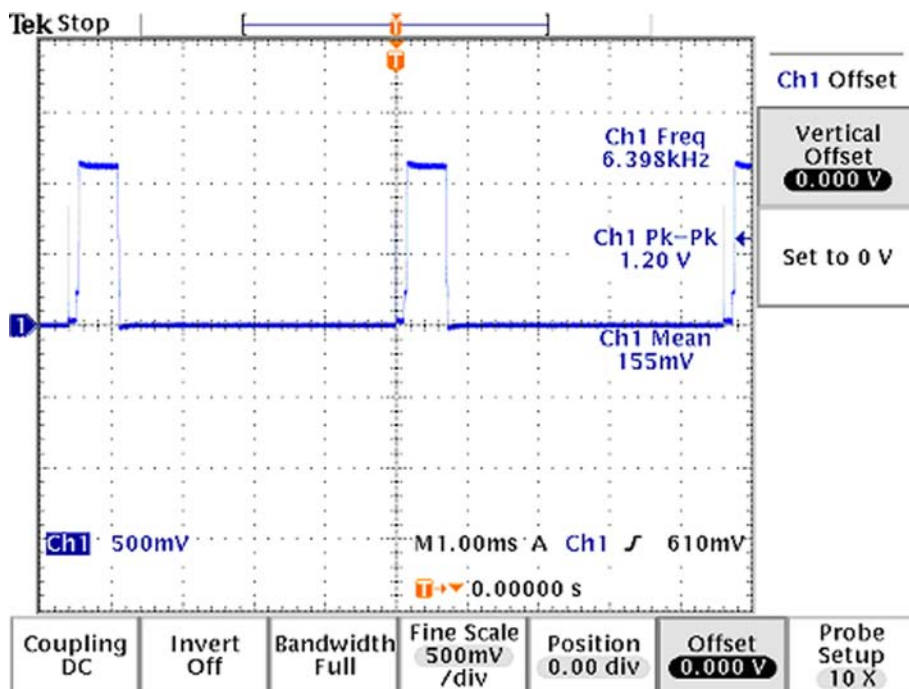

Figure 127 TXC signals at PCL5



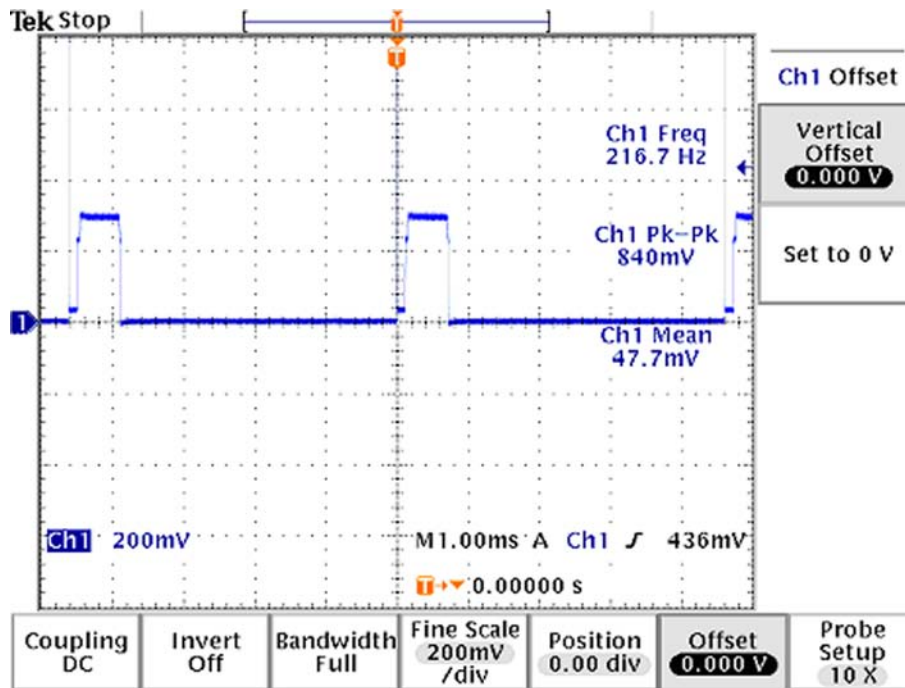

Figure 128 TXC signals at PCL19

## General instructions for GSM 1800 TX troubleshooting

### Steps

1. Apply a RF-cable to the RF-connector to allow the transmitted signal act as normal. RF-cable should be connected to an attenuator at least 10dB before connected to the measurement equipment, otherwise the PA may be damaged.
2. Start *Phoenix* and establish a connection to the phone with the data cable e.g. FBUS.
3. Select File and Scan product.
4. Wait a while for the PC to read the information from the phone.
5. Select Testing and RF Controls.
6. Set the parameters as follows:
  - i Band: GSM 1800
  - ii Active Unit: RX
  - iii TX Power Level: 5
  - iv TX Data Type: Random

7. The setup should now look like this:

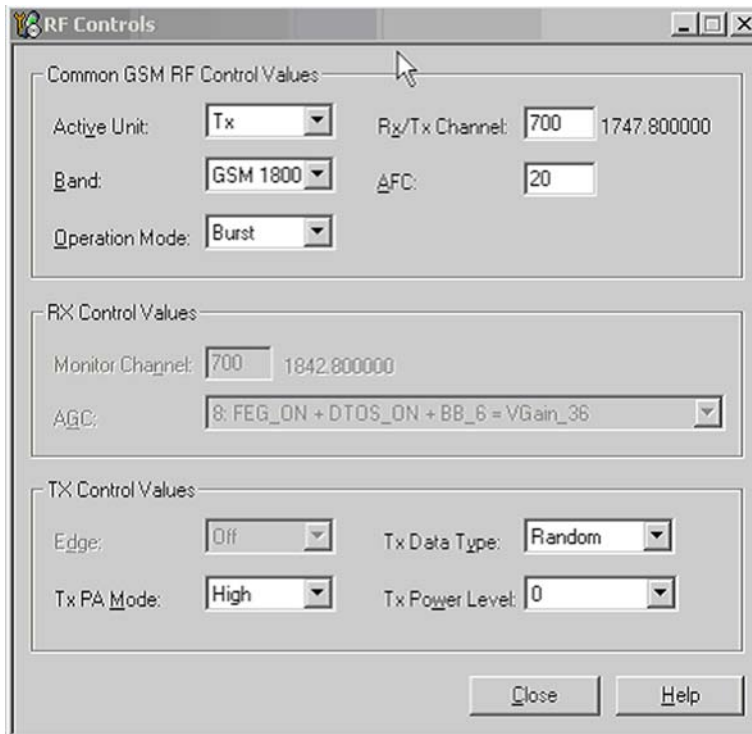

Figure 129 GSM 1800 RF controls window

**Troubleshooting diagram for GSM 1800 transmitter**

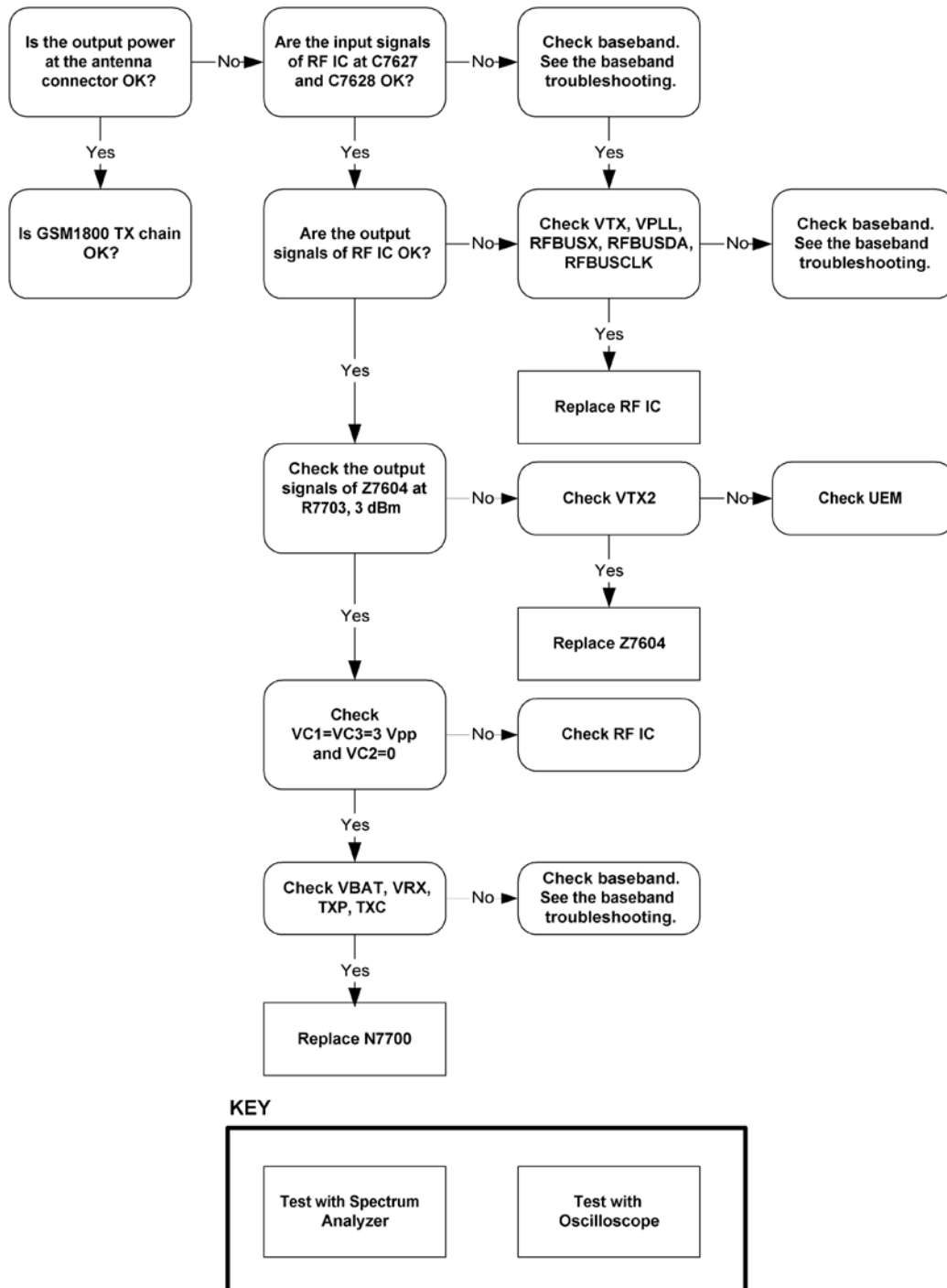

Figure 130 GSM 1800 transmitter troubleshooting

Measure the output power of the phone; it should be about 29.5dBm. Remember the cable loss is about 0.5dB.

**Results**

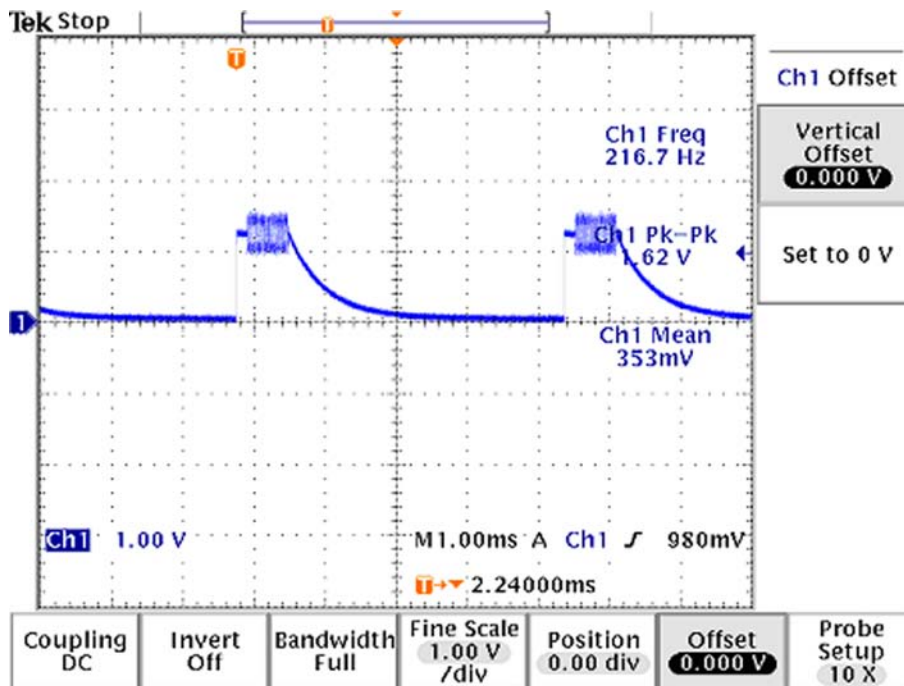

Figure 131 TX I/O signal

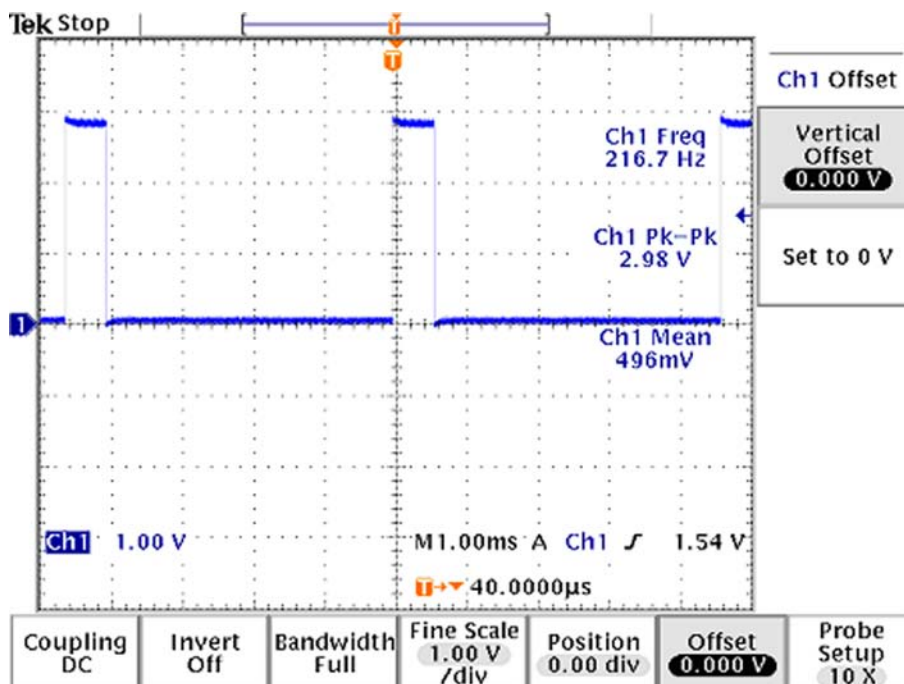

Figure 132 VC1, VC2, VC3 signals

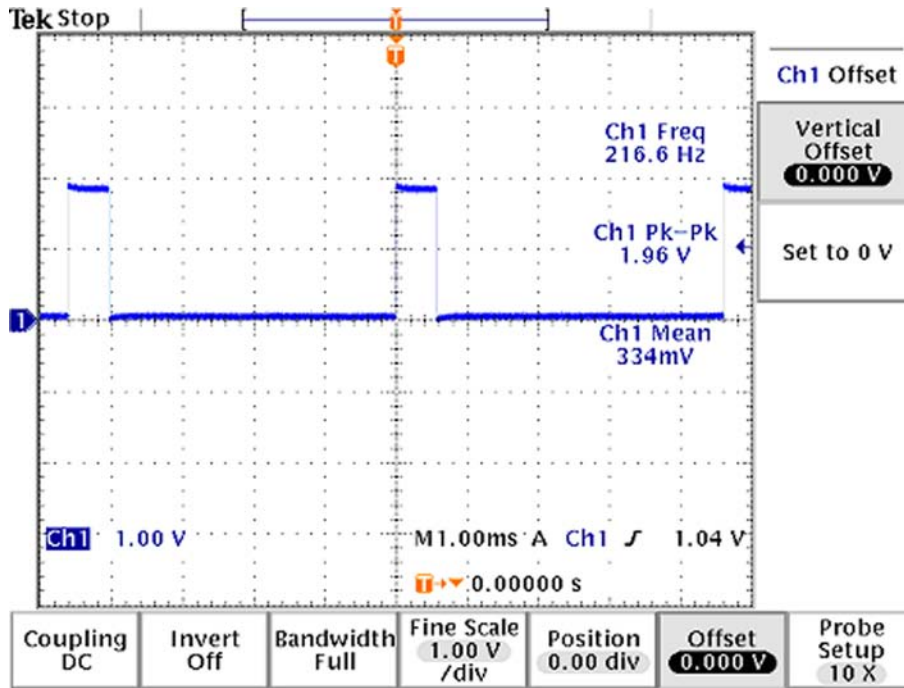

Figure 133 TXP signal

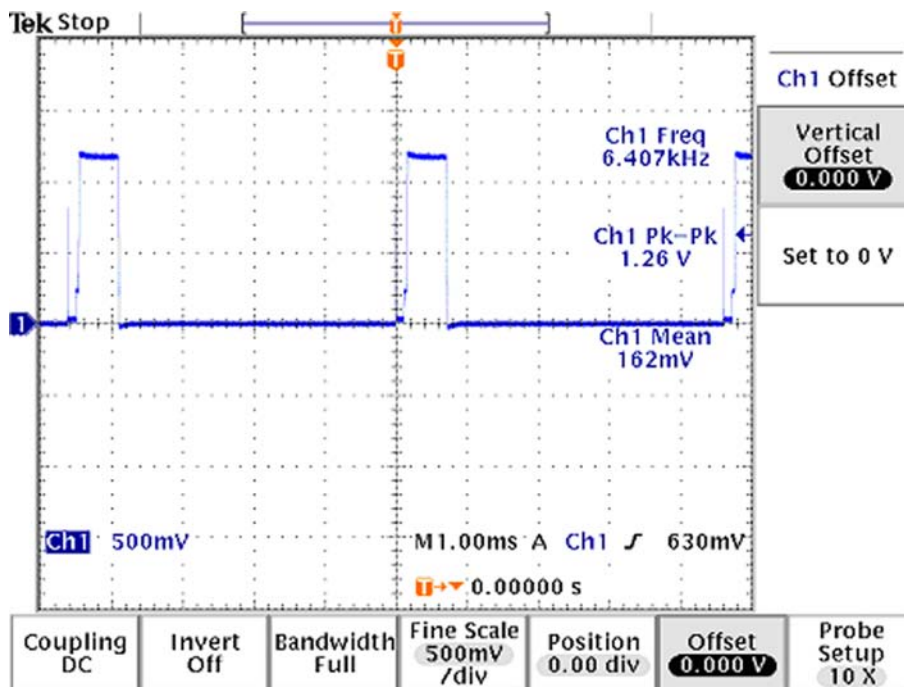

Figure 134 TXC signals at PCL0

### GSM 1800 TX output power

Measure the output power of the phone; it should be about 29.5 dBm. Remember the cable loss is about 0.5 dB.

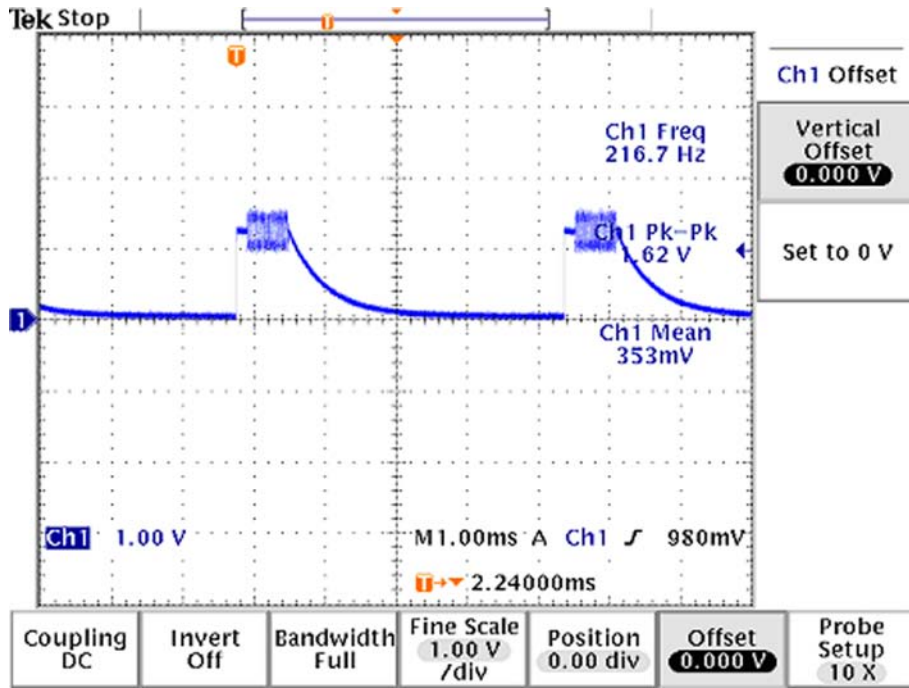

Figure 135 TX I/O signal

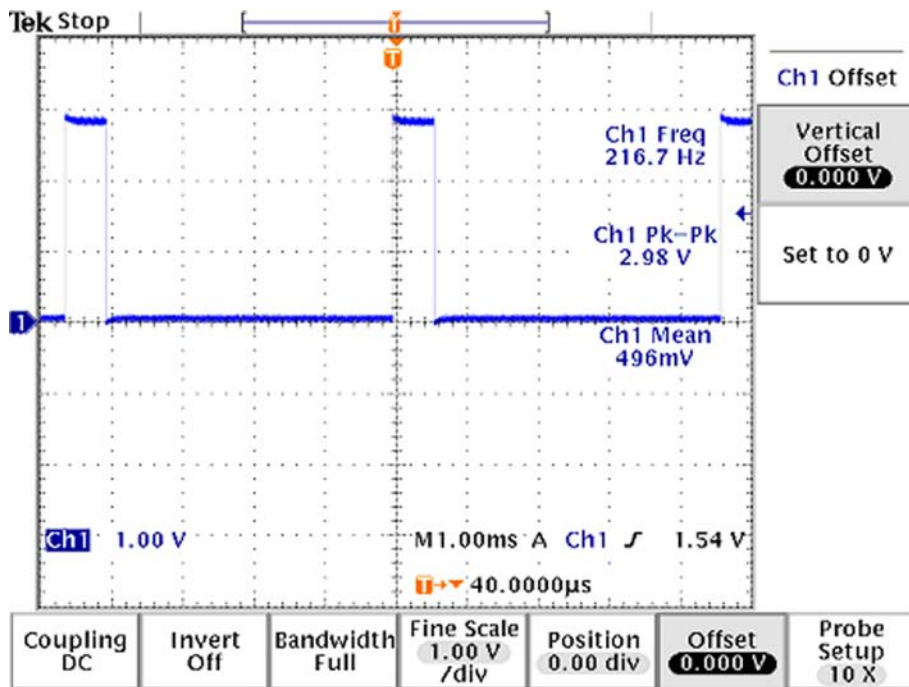

Figure 136 VC1, VC2, VC3 signals



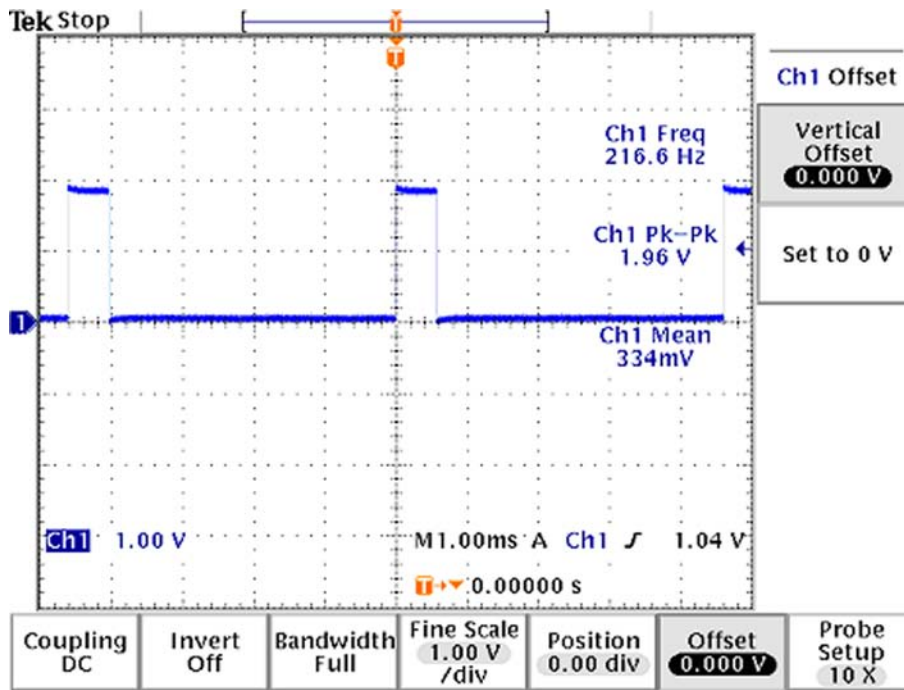

Figure 137 TXP signal

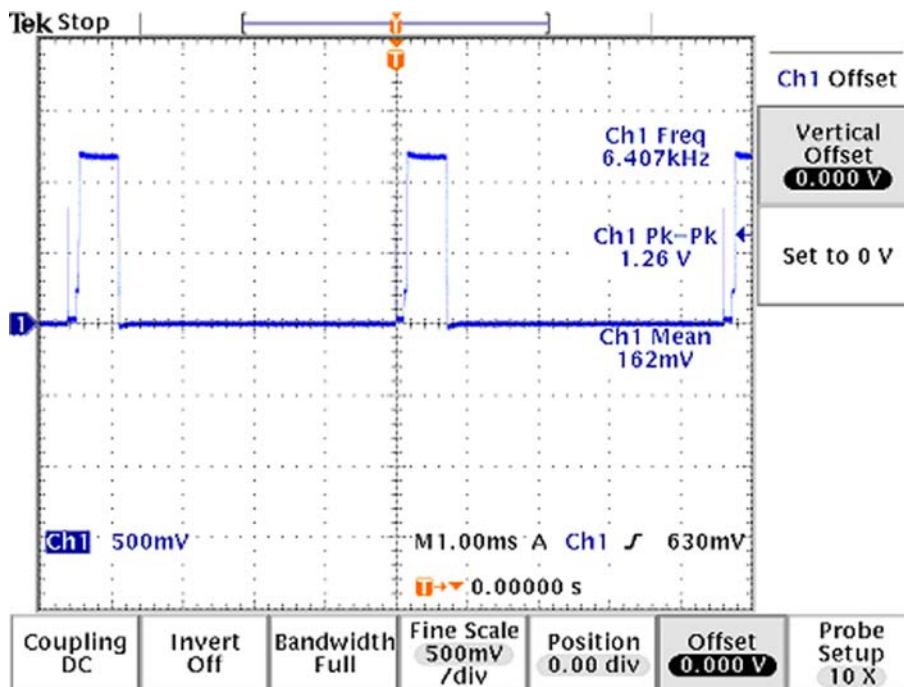

Figure 138 TXC signals at PCL0

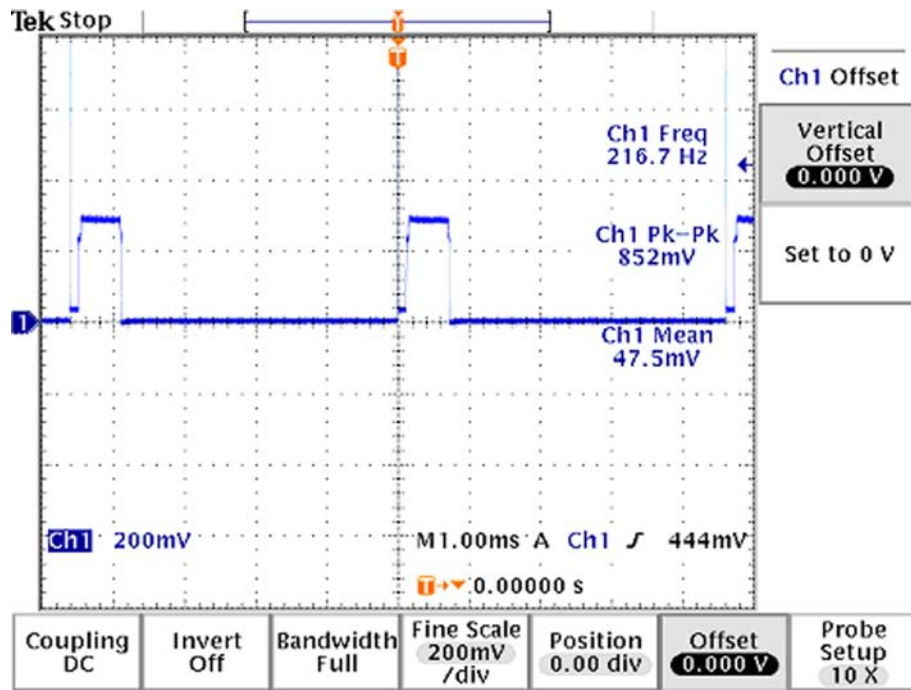

Figure 139 TXC signals at PCL15

## ■ Synthesizer troubleshooting

### Introduction

There is only one PLL synthesizer generating Local Oscillator frequencies for both RX and TX in both bands (PCN and EGSM). The VCO frequency is divided by 2 for PCN operation or by 4 for EGSM operation inside the RF IC.

The 26MHz oscillator is located near the RFIC (N7600). The coarse frequency for this oscillator is set by an external crystal (B7600). The reference oscillator is used as a reference frequency for the PLL synthesizer and as the system clock for the Baseband. The 26MHz signal is divided by 2 to achieve 13MHz inside the UPP IC (D2800).



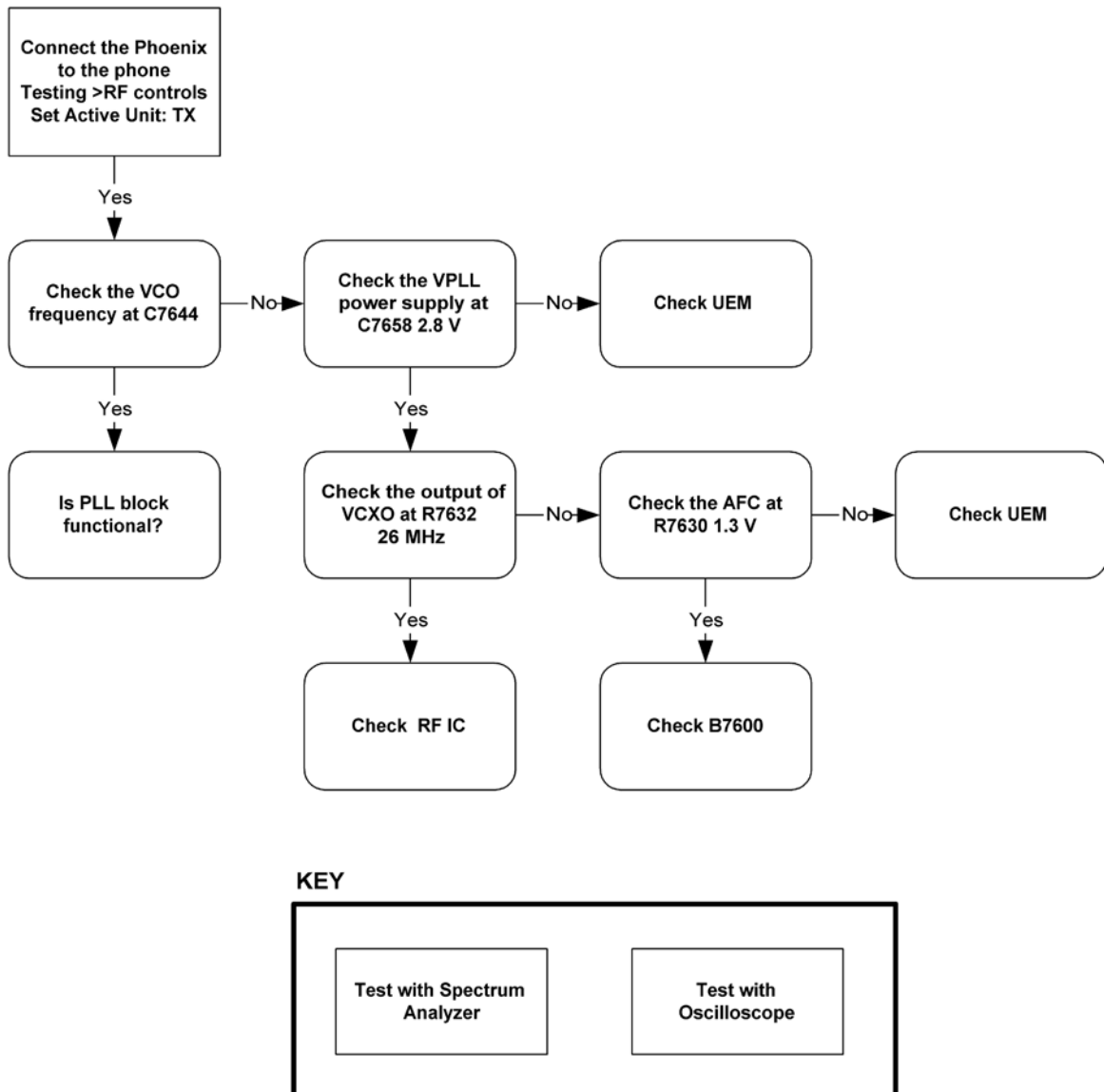

Figure 140 PLL Troubleshooting diagram

The 26MHz signal from the VCXO can be measured by probing R2900. The level at this point is approx. 770mVpp. Frequency of this oscillator is adjusted by changing the AFC-register inside the UEM IC. Example Signal Measured at VCXO output (R2900).

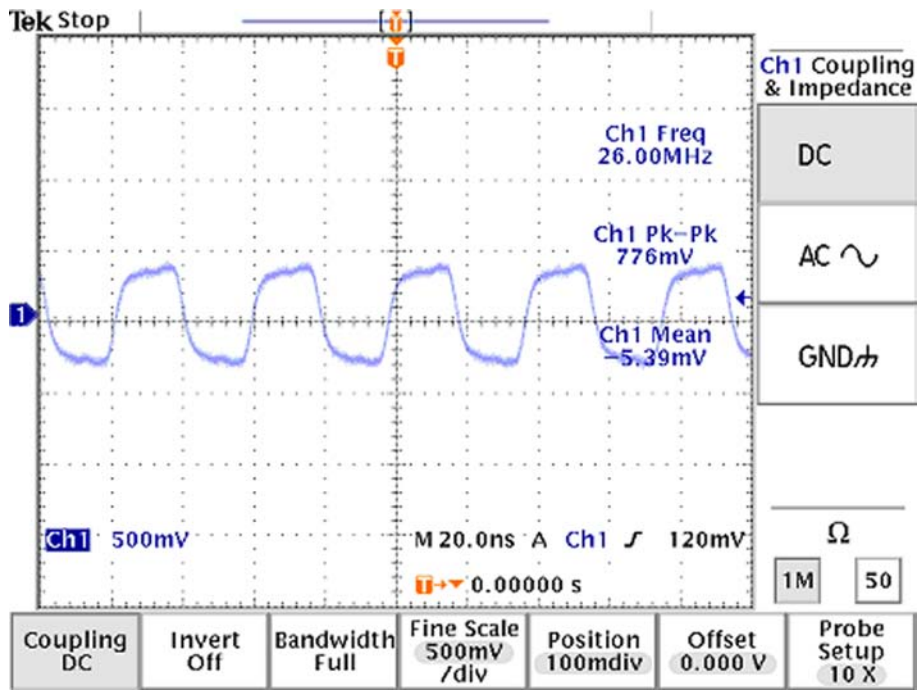

Figure 141 VCXO 26 MHz waveform

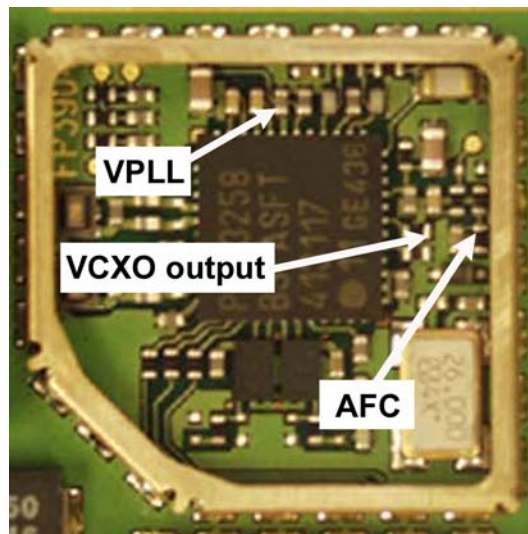

Figure 142 Measurement point for VCXO

## 8 — System module

(This page left intentionally blank.)

## Table of Contents

Block diagram.....	8-5
System module block diagram.....	8-5
Functional description.....	8-6
Baseband description.....	8-6
UPP.....	8-6
UEMCLite.....	8-6
External regulators.....	8-7
Energy management.....	8-7
Modes of operation.....	8-8
Voltage limits.....	8-9
Audio function description.....	8-9
External audio connector.....	8-11
External signals and connections.....	8-11
Interfaces.....	8-12
RF and baseband interfaces.....	8-12
Analogue Signals.....	8-15
LCD interface.....	8-16
Keyboard.....	8-16
SIM interface.....	8-17
External signals and connections.....	8-11
Battery connector.....	8-19
Battery.....	8-20
PWB outline.....	8-21
RF description.....	8-21
Frequency band, power and multi-slot class.....	8-21
Transmitter - general description.....	8-21
Transmitter - signal processing.....	8-22
VCXO and PLL.....	8-22

### List of Tables

Table 10 RF power supply.....	8-7
Table 11 Baseband power supply.....	8-7
Table 12 Voltage limits.....	8-9
Table 13 Connector for External Audio Accessories.....	8-11
Table 14 System connector.....	8-11
Table 15 AC and DC Characteristics of BB4.0 LiteV2 RF-Base band Digital Signals.....	8-12
Table 16 AC and DC Characteristics of RF-Base band Analogue Signals.....	8-15
Table 17 The electrical parameters.....	8-18
Table 18 System connector.....	8-11
Table 19 Battery IF.....	8-19
Table 20 Frequency bands and TX power class.....	8-21
Table 21 Multi-slot class.....	8-21

### List of Figures

Figure 143 Module block diagram.....	8-5
Figure 144 Power connection diagram.....	8-8
Figure 145 SIM filtering.....	8-8
Figure 146 Audio block diagram.....	8-10

Figure 147 4-pole jack plug for audio accessory.....8-11  
Figure 148 Keyboard schematics.....8-17  
Figure 149 Keyboard layout in UI side.....8-17  
Figure 150 BL-5C battery connection order.....8-20  
Figure 151 BL-5C battery block.....8-20  
Figure 152 PWB top side component placement.....8-21

■ **Block diagram**

**System module block diagram**

The main board consists of a radio frequency part and a baseband part. The User Interface parts are situated at the UI side, which is on the opposite side of the engine board. The 1MF is the system module of the mobile device.

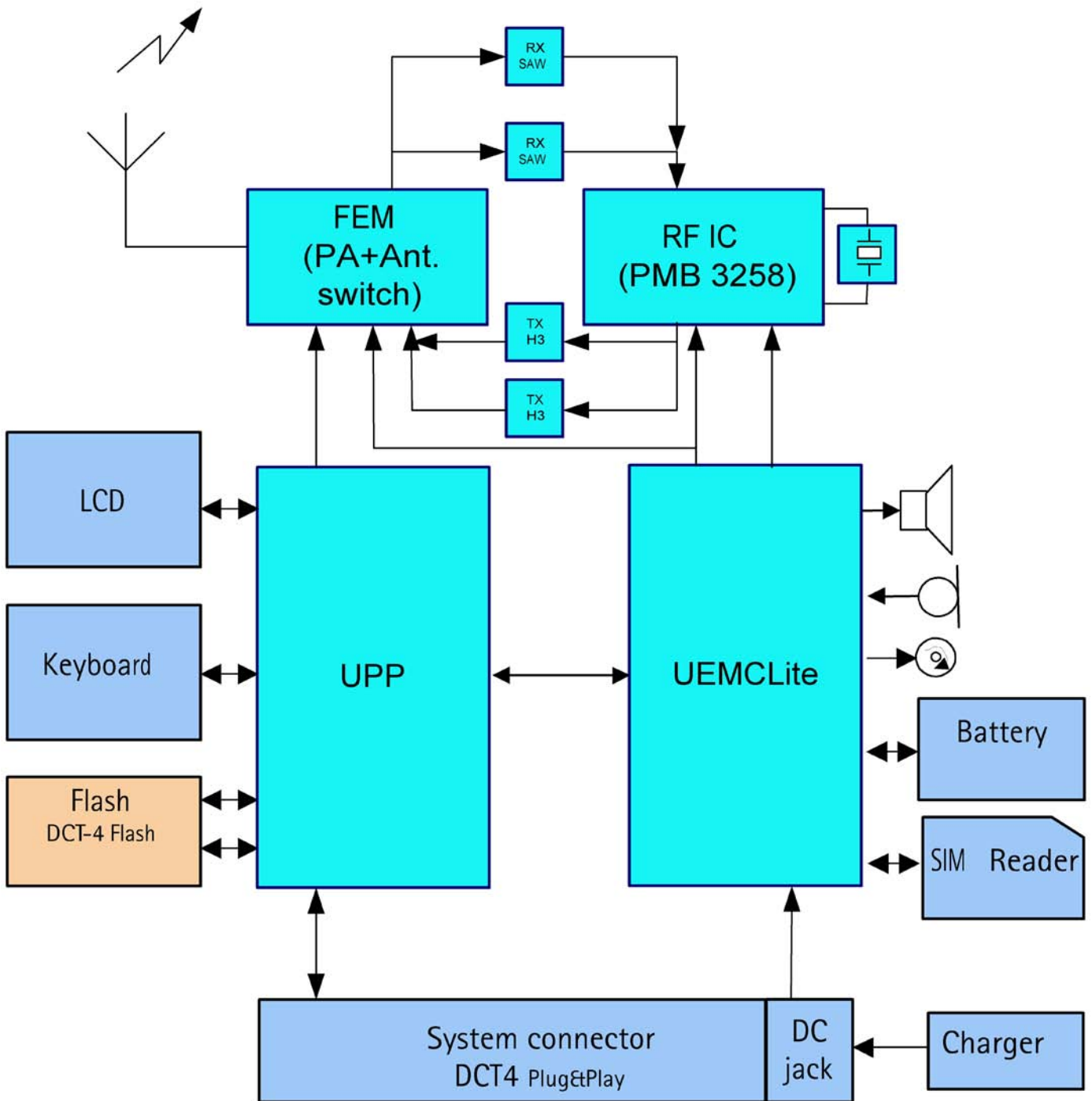

Figure 143 Module block diagram

## Functional description

The BB core is based on UPP4M CPU. UPP4M takes care of all the signal processing and operation controlling tasks of the mobile device. For power management, there is one main ASIC for controlling, charging and supplying power UEMCLite plus a discrete power supply. The UEMCLite generates the main reset for the system. Memories comprise 128 Mbit flash and 16 Mbit PsRAM. Memory devices are stacked on top of each other in a single Combo package.

The UEMCLite also handles the interface to the RF and audio sections. This ASIC provides A/D and D/A conversion of the in-phase and quadrature receive and transmit signal paths and also A/D and D/A conversions of received and transmitted audio signals. Data transmission between UEMCLite and RF and the UPP4M is implemented using different serial connections (CBUS, DBUS and RFBUS). UPP4M ASIC handles digital speech processing.

A real time clock function is integrated into UEMCLite, which utilizes the same 32 kHz-clock source as the sleep clock. The SLCK/RTC runs all time when the phone battery is connected. It is running also when the phone is switched off. In UEMCLite there is no back up battery/capacitor connection.

There are two audio transducers in the product; 13 mm speaker and a microphone. The speaker is used to generate audios for earpiece, IHF and ringing tones. A separate audio amplifier drives the speaker. There is only one microphone for both HS and IHF modes.

The display is a CSTN type color display with 65536 colors and 128 x 128 pixels with backlighting. The UI module features a function key mat with a 4-way navigation key with a center selection key.

## ■ Baseband description

### UPP

UPP (Universal Phone Processor) is the digital ASIC of the DCT4 generation base band. In LiteV2 BB the UPP4M\_v3/ UPP4Mv4 and UPP2Mv2 are supported types. UPP4Mv3 includes 4.5 Mbit internal RAM, ARM7TDMI rev4 16/32-bit RISC MCU core, TI Lead3 16-bit DSP phase2+ core with DMA controller, ROM for MCU boot code and all digital control logic. UPP general purpose IO (GENIO) can be used for predefined HW purpose or but they can also be controlled with SW for product specific features.

### Memory

This mobile uses two kinds of memories, Flash and Synchronous RAM (SRAM). These memories have are sharing the same bus interface to UPP4M. SDRAM is used as the working memory. Interface is 16 bit wide data and 14 bit address. Memory clocking speed is 52 MHz. The SRAM size is 16 Mbits.

SRAM I/O is 1.8 V and core 1.8 V supplied by UEMCLite regulator VIO. All memory contents are lost if the supply voltage is switched off.

Multiplexed flash memory interface is used to store the MCU program code and user data. The memory interface is a burst type FLASH with multiplexed address/data bus, running at 52 MHz.

Configuration of flash memory is a 128 Mbit NOR flash memory. Flash I/O and core voltage are 1.8 V supplied by UEMCLite's VIO.

### UEMCLite

Power management in the RM-74/75 follows the DCT4 Core design, having anyhow less regulators than traditional architecture. The UEMCLite, that is a low cost energy management ASIC with completely new design contains for BB use two 2.78V LDO regulators, 1.8V linear regulator, programmable 1.0 - 1.5 V linear regulator and 1.8/3.0 V LDO regulator. For RF use UEMCLite has five 2.78 V LDOs. In addition, the UEMCLite contains audio codec, A/D converters, RF converters, many drivers, etc.

Below is a list of the supply voltages.



**Table 10 RF power supply**

	Vmin/V	Vtyp/V	Vmax/V	ItypmA	I <sub>max</sub> mA	Notes
VR1	2.7	2.78	2.86	65	75	VTX (Supply voltage for PMB3258 LO and RX parts
VR2	2.7	2.78	2.78	2.4	3.0	VX0 (VCX0 supply voltage)
VR3	2.7	2.78	2.86	41	47	VTX2 (Supply voltage for PMB3258 modulator output stage)
VR4	2.7	2.78	2.86	43	48	VRX (Supply for RFIC RX and TX parts)
VR5	2.7	2.78	2.86	29	35	VPLL (Supply for VCO, PLL and digital parts)
VBATTRF	3.1	3.6	4.7	1.5	3.5	Supply voltage for the front-end module (V <sub>batt</sub> , max=6.0 V)

The table below shows the typical current consumption in different operation modes.

**Table 11 Baseband power supply**

Signal, Nom Volt., Max Current	Min-Max Voltage (V)	I <sub>qmax</sub>	PSSR(dB)*	Notes
VANA, 2,78V, 80mA	2.7-2.86	200	50, 40	Disabled in sleep mode
VBB1 2,78V, sleep 2mA, norm. 50mA	2.7-2.86	15 sleep, 200	40, -	Sleep mode possibility
VSIM, 1.8/3.0, 25mA	1.745- 1.8552.910- 3.090	30 sleep, 80	40, -	Sleep mode possibility, programmable
VIO, 1.8V	1.72 - 1.88	15 sleep, 100	45, -	Sleep mode possibility
VCORE,1.055/1.25/ 1.35/1.5V	1.0 - 1.111.188 - 1.3131.285 -1.4151.425 -1.575	20 sleep, 200	40, -	Sleep, programmable, Initial voltage 1.35V from reset

### External regulators

White LED Driver solution is implemented with DC/DC converter. The driver circuit is controlled by UEM output pin DLIGHT, which add external pull up using a digital transistor and one resistor. The schematics also combined the UEMIO (5) to control DC/DC enable as another optional using two jumper.

### Energy management

#### Filter components

The master of EM control is UEMCLite and with SW it has the main control of the system voltages and operating modes. The power distribution diagram is presented in the illustration below.

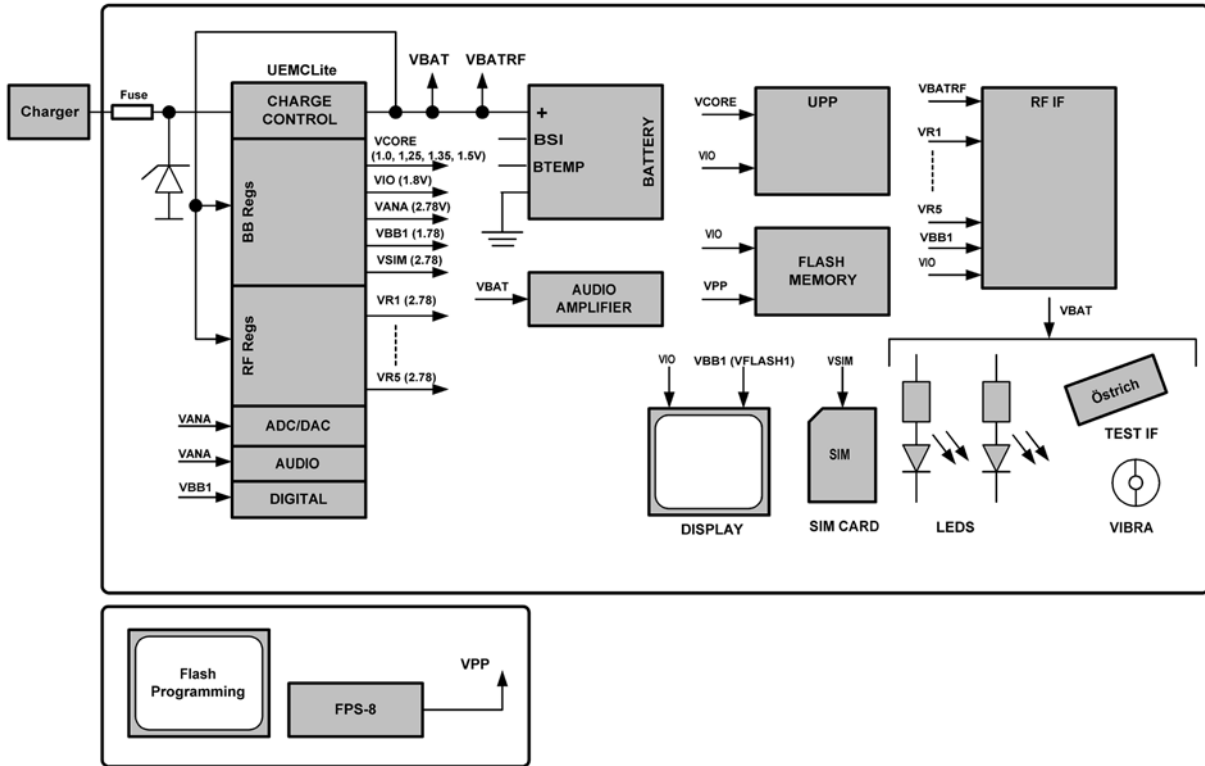

Figure 144 Power connection diagram

All connectors going to the “outside world” have filter components, ESD protection and EMC reduction. The Digital/Data lines on SIM have special dedicated filter ASIP. The below figure show the SIM filtering.

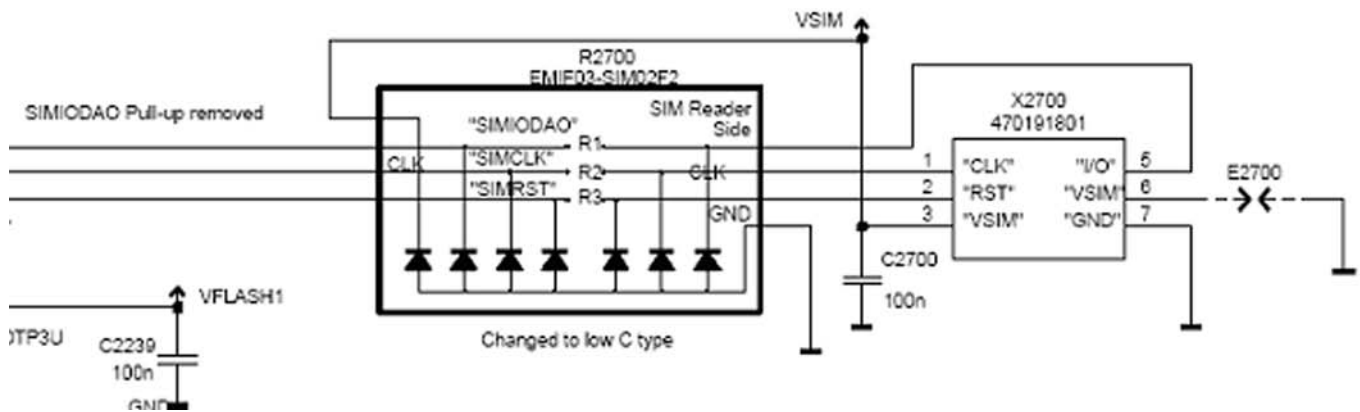

Figure 145 SIM filtering

The Audio circuit: Earpiece, IHF, internal microphone and external speaker are filtered with discrete components (common mode reduction coils, Varistors, caps and resistors), whereas the external microphone uses differential mode mic. ASIP

The 16 UEMECLite BB & RF regulators are specified to have a decoupling cap of 1  $\mu\text{F} \pm 20\%$ .

## Modes of operation

BB4.0 LiteV2 base band has five different functional modes, which are defined in UEMCLite specification:

- **No supply:** In NO\_SUPPLY mode, the phone has no supply voltage. This mode is due to disconnection of main battery or low battery voltage level in battery. Phone is exiting from NO\_SUPPLY mode when sufficient battery voltage level is detected. Battery voltage can rise either by connecting a new battery with VBAT > VMSTR+ or by connecting charger and charging the battery above VMSTR+.
- **Acting Dead:** If the phone is off when the charger is connected, the phone is powered on but enters a state called "Acting Dead". To the user, the phone acts as if it was switched off. A battery charging alert is given and/or a battery charging indication on the display is shown to acknowledge the user that the battery is being charged.
- **Active:** In the Active mode the phone is in normal operation, scanning for channels, listening to a base station, transmitting and processing information. There are several sub-states in the active mode depending on if the phone is in burst reception, burst transmission, if DSP is working etc. One of the sub-states of the active mode is FM radio on state. In that case, Audio Amplifier and FM radio are powered on. FM radio circuitry is controlled by the MCU and 32kHz-reference clock is generated in the UPP. BBLite supports also the MIC3 audio path enabling also in the sleep mode allowing for example the FM radio listening during sleep mode. This requires that the FM radio work with 32kHz sleep clock frequency.

In Active mode the RF regulators are controlled by SW writing into UEMCLite's registers wanted settings: VR regulators can be disabled, enabled or forced into low quiescent current mode. VR2 is always enabled in Active mode for system clock chain supply

- **Sleep:** In sleep mode VCTCX0 is shut down and 32 kHz sleep clock oscillator is used as reference clock for the base band.
- **Charging:** Charging can be performed in any operating mode. The battery type / size is indicated by a resistor inside the battery pack. The resistor value corresponds to a specific battery capacity. This capacity value is related to the battery technology as different capacity values are achieved by using different battery technology. The battery voltage, temperature, size and current are measured by the UEMCLite and controlled by the charging software running in the UPP. The charging control circuitry (CHACON) inside the UEMCLite controls the charging current delivered from the charger to the battery. The battery voltage rise is limited by turning the UEMCLite switch off when the battery voltage has reached 4.2 V. Charging current is monitored by measuring the voltage drop across a 220 mW resistor. The PWM output doesn't exist any more from UEMCLite to the bottom connector

## Voltage limits

**Table 12 Voltage limits**

Parameter	Description	Value/V
Vmstr+	Master reset threshold (rising)	2.1 ±0.1
Vmstr-	Master reset threshold (falling)	1.9 ±0.1
Vcoff+	Hardware cutoff (rising)	3.1 ±0.1
Vcoff-	Hardware cutoff (falling)	2.8 ±0.1
SW shutdown	SW cutoff limit (> regulator drop-out limit) MIN!	3.2 V

## Audio function description

### Audio

The basic audio structure and communication between HW-audio modules and the audio ASIC's is illustrated in the block diagram below.

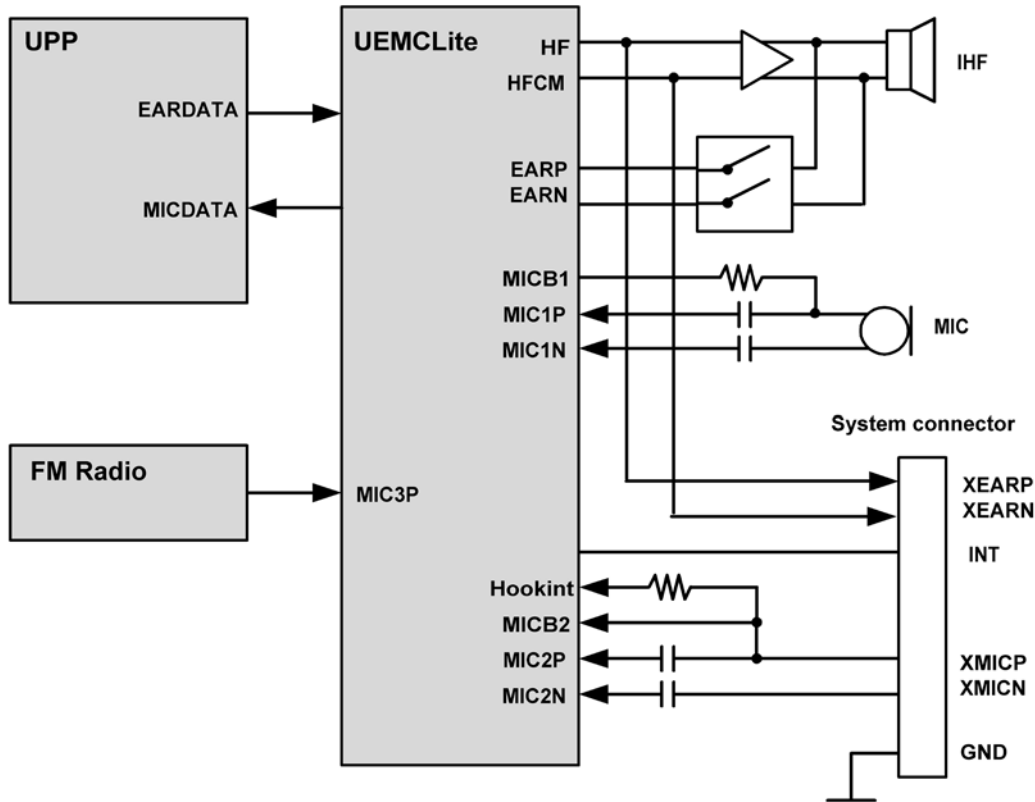

Figure 146 Audio block diagram

UEMCLite supports three microphone inputs and two earphone outputs. The microphone signals from different sources are connected to separate inputs at the UEMCLite ASIC. The inputs and outputs are all differential.

Three inputs (MIC1, MIC2, MIC3) and two outputs (EAR, HF/HFCM) are used. MIC1P/MIC1N input is used for the internal microphone, using single-ended biasing circuitry. EARP/EARN output from UEMCLite is used for hand-portable mode.

Uplink external audio (headset as well as car kit) is connected to MIC2P/MIC2N, while downlink audio is provided via the HF/HFCM output from UEMCLite. The car kit only can be used with external microphone connected.

MIC3 (positive input) connects to single ended outputs from the FM radio. The other input MIC3N is AC-coupled to GND.

The audio control is taken care of by UEMCLite, which contains the MCU and audio codec. Input and output selection, and gain control is performed inside UEMCLite. DTMF-tones and other audio tones are generated and encoded by UPP and transmitted to UEMCLite for decoding.

An external amplifier (D-class) is connected to provide sufficient power for an 8 W load. The inputs are wired to the headset connections HF and HFCM from UEMCLite.

EARP/N output is used for hand-portable speech, connected with PA output through switches.

Under normal conditions HF and HFCM is used for downlink audio to the headset/car kit. During headset/car kit usage the audio amplifier is disabled by means of the shutdown pin. Keeping the shutdown pin "low" also during sleep, secures a minimum amount of standby current to be consumed.

SMD vibra has a diameter is about 4.0-mm. Vibra is driven by PWM signal, generating vibration by rotating an un-balanced mass (counter weight) with radius of R=2.3-mm. The vibration signal is used as a silent alert call and also as a noticeable shock in gaming.

### External audio connector

The system connector, containing a 4-pole Jack plug, gains the access to the external audio interface. The Jack plug, which is integrated in the system connector, contains a mechanical switch, which is used to detect the connection of the accessories. The configuration for the 4-pole Jack-plug is shown in the following figure.

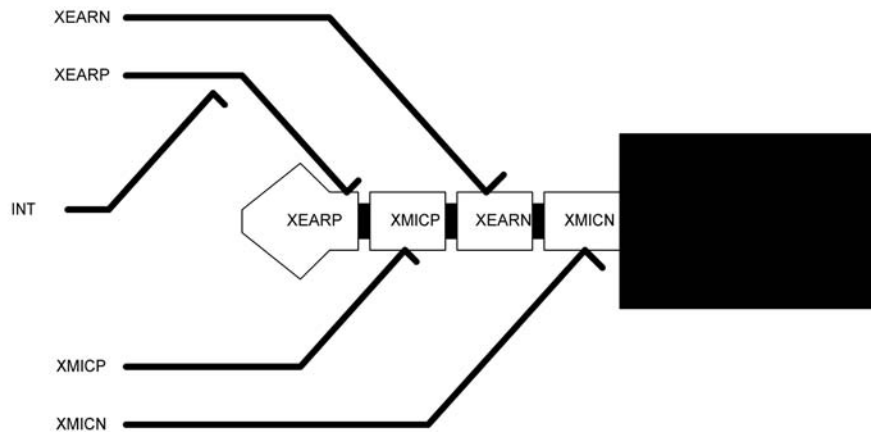

Figure 147 4-pole jack plug for audio accessory

**Table 13 Connector for External Audio Accessories**

Line symbol	Function
XMICP	External microphone signal input
XMICN	External microphone signal input
XEARP	External earphone signal output
XEARN	External earphone signal output
INT	Accessory detection
GND	Ground (Only used by PPH-1)

### External signals and connections

**Table 14 System connector**

Signal	From	To	Min	Nom	Max	Condi-tion	Note
XMICP	HS/HF Mic	UEMC Lite		2/60mV diff		Analog audio in	Headset Mic bias and audio signal 2mV nominal. HF Mic signal 60mV nominal. Differential symmetric input.
						DC bias 2V2kohm	Accessory detection by bias loading
XMICN				2/60mV diff		Ana in / 1k to GND	Hook interrupt by heavy bias loading

Signal	From	To	Min	Nom	Max	Condition	Note
XEARP	HS/HF	UEMC Lite		100 mV diff		Ana in	Quasi-differential DC-coupled earpiece/HF amplifier signal to accessory. DC biased to 0.8V
XEARN	EAR/Amp.						
INT HEADINT	Switch	UEMC Lite		0/2.7V		Dig in	HS interrupt from bottom connector switch when plug inserted.
VCHARIN	Charger	UEMC Lite		11.1Vp eak	16.9 Vpeak	Standard	Vch from Charger Connector, max 20V
					7.9 VRMS		
					1.0 Apeak		
			7.0 VRMS	8.4 VRMS	9.2 VRMS	Fast charger	
		850 mA					
GND					GND		GND from/to Charger connector

## ■ Interfaces

### RF and baseband interfaces

**Table 15 AC and DC Characteristics of BB4.0 LiteV2 RF-Base band Digital Signals**

Signal name	From	To	Para-meter	Input characteristics				Function
				Min	Typ	Max	Unit	
TXP1	UPP	RF-IC	1	1.38		1.88	V	Depends of the RF design
RFGGenOut 3	GenI05		0	0		0.4	V	
			Load Resistance	10			kW	
			Load Capacitance			20	pF	
			Timing Accuracy			¼	symbol	

Signal name	From	To	Para-meter	Input characteristics				Function
				Min	Typ	Max	Unit	
TXP2	UPP (GenIO6)	RF-IC	1	1.38		1.88	V	Depends of the RF design
			0	0		0.4	V	
			Load Resistance	10			kW	
			Load Capacitance			20	pF	
			Timing Accuracy			¼	symbol	
RFBusEn1X	UPP	RF-IC	1	1.38		1.88	V	RFIC Chip SelX
			0	0		0.4	V	
			Internal PU Current			50	uA	
			Load resistance	10			kW	
			Load capacitance			20	pF	
RFBusDa	UPP / RF-IC	RF- IC/ UPP	1	1.38		1.88	V	Bi-directional RF Control serial bus data,
			0	0		0.4	V	
			Load resistance	10			kW	
			Load capacitance			20	pF	
			Data frequency			13	MHz	
RFBusClk	UPP	RF IC	1	1.38		1.88	V	RF Control serial bus bit clock
			0	0		0.4	V	
			Load resistance	10			kW	
			Load capacitance			20	pF	
			Data frequency			13	MHz	

Signal name	From	To	Para-meter	Input characteristics				Function
				Min	Typ	Max	Unit	
GENIO3	UEMCLite	RF IC	1		2.78		V	RF Control *
			0				V	Depends of the RF design
			Load resistance				kW	
			Output current			4	mA	
GENIO4	UEMCLite	RF IC	1		2.78		V	Audio clock input in UEMCLiteV3 and Littiv2
			0				V	
			Load resistance				kW	
			Output current			4	mA	
GENIO5	UEMCLite	RF IC	1		2.78		V	RF Control *
			0				V	Depends of the RF design
			Load resistance				kW	
			Output current			4	mA	



## Analogue Signals

**Table 16 AC and DC Characteristics of RF-Base band Analogue Signals**

Signal name	From	To	Parameter	Min	Typ	Max	Unit	Function
RFCLK	VCTCXO	UPP	Frequency		13/26		MHz	System Clk from RF to BB,
			Signal amplitude	0.2	0.8	1.32	Vpp	13/26 MHz Depending on RF chipset
			Input Impedance	10			kW	UPP minimum recommended amplitude is 0.3Vpp.
			Input Capacitance			10	pF	
			Harmonic Content			-8	dBc	
			Clear signal window (no glitch)	200			mVpp	
			Duty Cycle	40		60	%	
RFCLKGnd	VCTCXO	UPP	DC Level		0		V	System Clock slicer Ref GND, not separated from pwb GND layer
RXIP, RXIN, RXQP, RXQN	RF-IC	UEMCLite	Voltage swing (static)		1.4	1.45	Vpp	Differential positive / negative in-phase and quadrature Rx Signals.
			DC level	1.3	1.35	1.4	V	
			I/Q amplitude mismatch			0.2	dB	
			I/Q phase mismatch	-0.5		0.5	deg	
TXIP, TXIN, TXQP, TXQN	UEMCLite	RF-IC	Differential voltage swing (static)	2.25		2.45	Vpp	Differential positive / negative in-phase and quadrature Tx Signals
								In High-Z when RX is receiving.
			DC level	1.17	1.20	1.23	V	
			Source Impedance			200	W	

Signal name	From	To	Parameter	Min	Typ	Max	Unit	Function
AFC	UEMCLite	VCTCX0	Voltage Min	0.0		0.1	V	Automatic Frequency Control signal for VCTCX0 Programmable
	(AFCOUT)		Max	2.4		2.55		
			Resolution	11			bits	
			Load resistance	1			kW	
			and capacitance			100	nF	
			Source Impedance			200	W	
			Output impedance	10			MW	Path powered down
TxC	UEMCLite	RF-IC	Voltage Min			0.1	V	Transmitter power level and ramping control, Ref UEMCLite RF converter specification
	(AUXOUT)		Max	2.4				
			Source Impedance			200	W	
			Resolution	10			bits	
VCXOTEMP	RF-IC	UEMCLite	Input voltage range	0		2.7	V	
			Input resistance	900		6000	Ohm	
			Resolution	10			bits	
PATEMP	RF-IC	UEMCLite	Voltage at -20oC		1.57		V	Usage depends of the RF design

### LCD interface

The figure below illustrates the structure of LCD module. LCD module includes UV tape, Driver IC, Prism sheet, LGP, Flex Assy, label Tape, Adhesive Tape, Protection film, LCD glass, Rim Tape, Diffuser, Reflector and Holder Frame.

LCD panel includes upper and lower polarizers, LCD transfective glass, single chip COG driver with 132x132x116bit RAM, 10-pin board-to-board connector and FPC with discrete components.

### Keyboard

A 5 X 5 matrix keyboard consists of 21keys, one 10-channel integrated passive filter arrays with downstream ESD protection of >8KV connect the matrix keyboard to UPP.

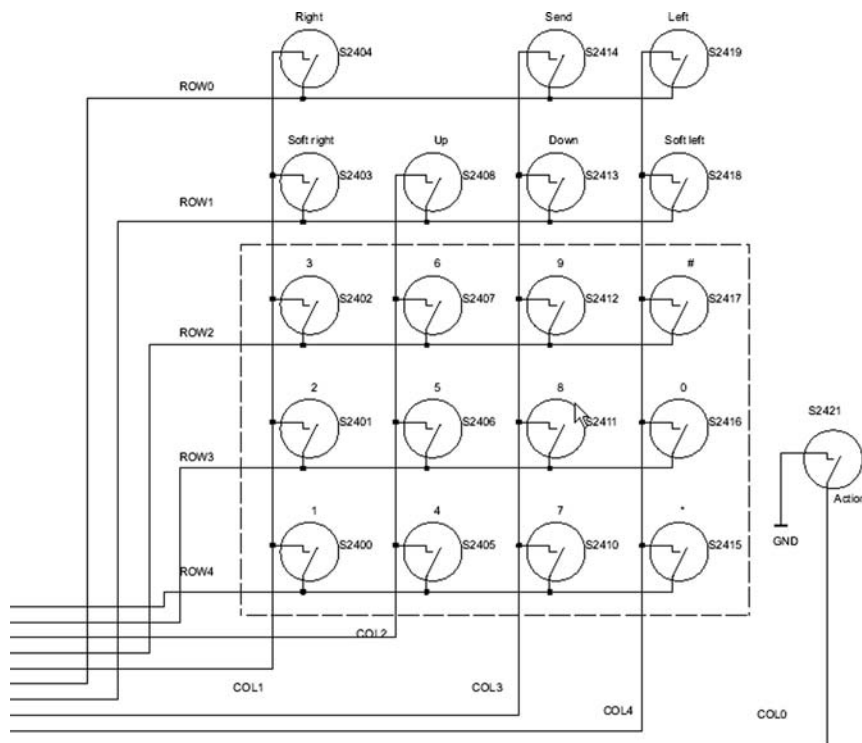

Figure 148 Keyboard schematics

The layout is shown in Keyboard layout in UI side.

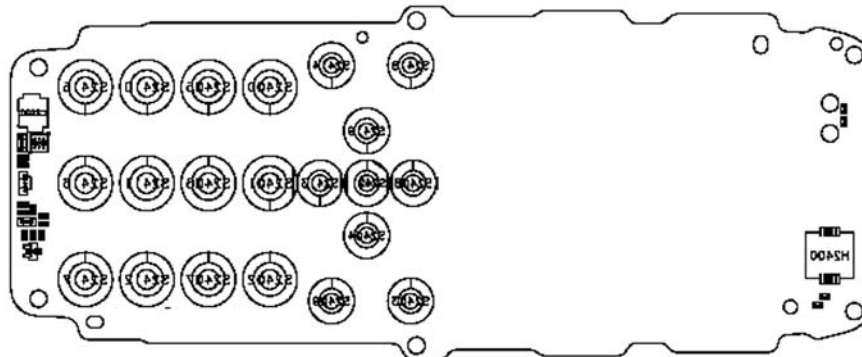

Figure 149 Keyboard layout in UI side

### SIM interface

The SIM interface is programmed to support 3V and 1.8V SIMs. SIM supply voltage is selected by with register in the UEMCLite. It is only allowed to change the SIM supply voltage when the SIM IF is powered down. The SIM power up/down sequence is generated in the UEMCLite.

The SIM interface is powered up when the SIMCardDet signal indicates "card in". This signal is derived from the BSI signal.

SIM interface is implemented in two ASICs, UPP and UEMCLite. The SIM interface is the electrical interface between the Subscriber Identity Module Card (SIM Card) and mobile phone (via UEMCLite device).

**Table 17 The electrical parameters**

Pin	Name	Parameter	Min	Typ	Max	Unit	Notes
1	VSIM	1.8V SIM Card	1.6	1.8	1.9	V	Supply voltage
		3V SIM Card	2.8	3.0	3.2	V	
2	SIMRST	1.8V SIM Card	0.9xVSIM		VSIM	V	SIM reset (output)
			0		0.15xVSIM		
		3V SIM Card	0.9xVSIM		VSIM	V	
			0		0.15xVSIM		
3	SIMCLK	Frequency		3.25		MHz	SIM clock. UPP4Mv3 and UPP4mv4 support 3GPP Release 5, SIMCLK/8 data rate. UPP2Mv2 supports SIMCLK/16 data rate.
		Trise/Tfall			50	ns	
		1.8V Voh	0.9xVSIM		VSIM	V	
		1.8V Vol	0				
		3V Voh	0.9xVSIM		VSIM	V	
		3V Vol	0				
4	DATA	1.8V Voh	0.9xVSIM		VSIM	V	SIM data (output)
		1.8V Vol	0		0.15xVSIM		
		3V Voh	0.9xVSIM		VSIM		
		3V Vol	0		0.15xVSIM		
		1.8V Vih	0.7xVSIM		VSIM	V	SIM data (input)
		1.8V Vil	0		0.15xVSIM		Trise/Tfall max 1us
		3V Vil	0.7xVSIM		VSIM		
		3V Vil	0		0.15xVSIM		
5	NC					Not connected	
6	GND	GND	0		0	V	Ground

VSIM specified in regulator section in this document

## External signals and connections

**Table 18 System connector**

Signal	From	To	Min	Nom	Max	Condi-tion	Note
XMICP	HS/HF Mic	UEMC Lite		2/60mV diff		Analog audio in	Headset Mic bias and audio signal 2mV nominal. HF Mic signal 60mV nominal. Differential symmetric input.
						DC bias 2V2kohm	
XMICN				2/60mV diff		Ana in / 1k to GND	Hook interrupt by heavy bias loading
XEARP	HS/HF	UEMC Lite		100 mV diff		Ana in	Quasi-differential DC-coupled earpiece/HF amplifier signal to accessory. DC biased to 0.8V
XEARN	EAR/ Amp.						
INT HEADINT	Switch	UEMC Lite		0/2.7V		Dig in	HS interrupt from bottom connector switch when plug inserted.
VCHARIN	Charger	UEMC Lite		11.1Vp eak	16.9 Vpeak	Standard	Vch from Charger Connector, max 20V
					7.9 VRMS		
					1.0 Apeak		
			7.0 VRMS	8.4 VRMS	9.2 VRMS	Fast charger	
		850 mA					
GND					GND		GND from/to Charger connector

## Battery connector

Internal, user-changeable batteries. Semi-fixed. Types: Li-Ion, NiMH. Interface, 4 terminals (VBATT, GND, BSI, BTEMP) Janette battery interface is used. The battery type and size are defined in the next chapter.

**Table 19 Battery IF**

Signal	From	To	Min	Nom	Max	Condi-tion	Note
GND	Global	Batt (-)					Global GND
VBAT		Batt (+)	3.1		5.1		Battery Voltage

Signal	From	To	Min	Nom	Max	Condi-tion	Note
BSI		UEMCLite	0		2.78		Analog input, Battery Size Indicator Resistor, 100 kohm pull up to 2.78V (VBB1). FDL Init, refer to flash download.
BTEMP		UEMCLite	0		2.78		Btemp NTC Resistor, 100 kohm pull up to 2.78V (VANA)

\* Note! In BL-5C battery IF the BTEMP signal doesn't exists. Temperature measurement is done on system board with NTC resistor.

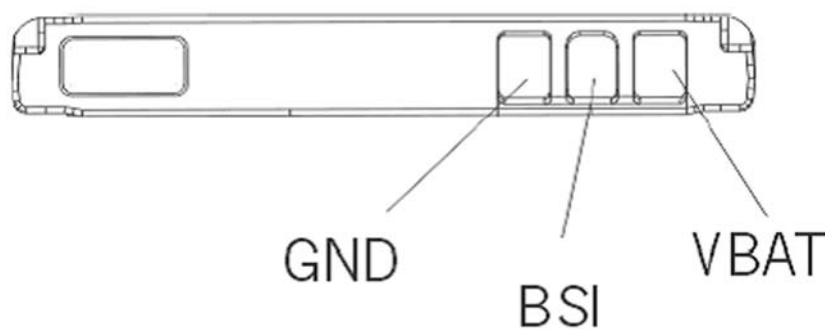

Figure 150 BL-5C battery connection order

**Battery**

- Type: BL-5C
- Technology: Li-Ion, 4.2 V charging, 3.1 V cut-off
- Capacity: 900 mAh.

The BSI resistor is placed on the main PWB as the telephone supports only one battery capacity. Further a BSI connection is added to the Flash interface. The battery temperature is measured by a NTC resistor placed on the main PWB, opposite to the Battery. Battery pack has an impedance of 130 - 150 mΩ (0 - 45 °C).

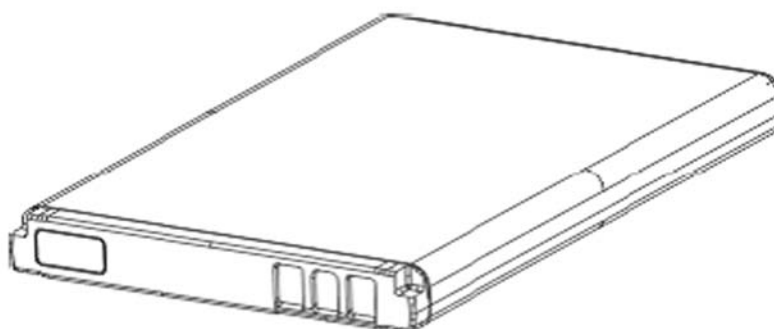

Figure 151 BL-5C battery block

## PWB outline

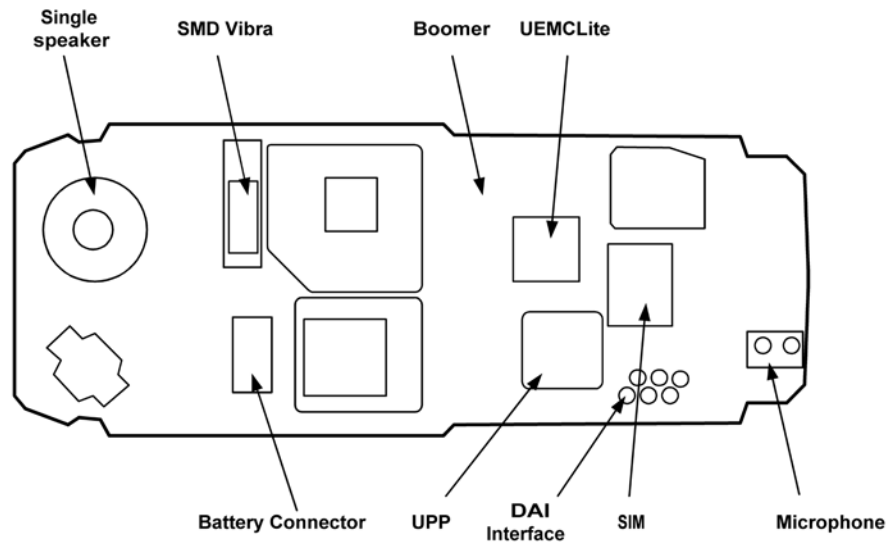

Figure 152 PWB top side component placement

## ■ RF description

### Frequency band, power and multi-slot class

The requirements leads to the specification in the table below:

**Table 20 Frequency bands and TX power class**

System	Frequency band	TX power class
GSM850	Tx: 824 – 849 MHz	4 (33dBm)
GSM900	Tx: 880 – 915 MHz	4 (33dBm)
	Rx: 925 – 960 MHz	
GSM1800	Tx: 1710 – 1785 MHz	1 (30dBm)
	Rx: 1805 – 1880 MHz	
GSM1900	Tx: 1850 – 1910 MHz	1 (30dBm)
	Rx: 1930 – 1990 MHz	

**Table 21 Multi-slot class**

Multislot Class	
GPRS	MSC 6 (up to 3+1 and 2+2)

### Transmitter - general description

The transmitter has 2 separate parallel paths one covering either the 850 or the 900 band and the other the 1800/1900 bands. The transmitter operates in GMSK mode only. The power level control circuitry is integrated in the front-end module.

Each path of the transmitter is composed of a baseband lowpass filter for the I/Q signals and a quadrature direct modulator integrated in PMB3258. At the modulator's output there is a bandpass filter for each band (so-called H3 filter) and a balun transformer to convert the differential output signal from the modulator into a single-ended 50 ohm signal. This signal is fed into the input of the PA. The two power amplifiers and the antenna switch are located in a single module with built-in power control loop.

The two control methods used are open-loop Vcc control (RFMD) and feedback control with current sensing (Renesas, Philips). The reference waveform (TXC) for the control loop comes from the baseband. The output of the PA goes into a low pass filter located inside the FEM (Front End Module). Finally the transmit signal goes through the band selection and TX/RX switches to the antenna port.

The FEM is controlled with four digital control signals (TXP, Vc1, Vc2 and Vc3) to meet the TDMA frame timing requirements.

### **Transmitter - signal processing**

The I/Q signals coming from the baseband section are fed into the modulator and converted up to the carrier frequency. The I/Q are post filtered by a 1st order passive RC filter (discrete components on PWB) and a 3rd order active filter (Legendre type) inside PMB3258.

The nominal output level of the modulator is +3.5 dBm in both bands. The modulator's output is an open-collector type and need an external load and a DC supply feed. The load and the DC supply feed are implemented as the part of the H3 filter. The H3 filter will attenuate mainly the 2nd and 3rd harmonics of the modulated RF signal and provide suitable termination impedance for the modulator on the fundamental and harmonic frequencies. Owing to the low noise floor of the PMB3258 modulator a narrow-band filter for the TX noise is not required on either band, although the margin to the specification limit is quite narrow in the GSM850/900 bands.

The filtered signal is fed into the input of the FEM, which amplifies it to the desired power level and provides the signal at the antenna port. There are built-in lowpass filters for the TX harmonics in the front-end module. There is also a temperature sensor close to the FEM to enable SW temperature compensation for e.g. the power levels. The sensor is connected to one of the slow ADC channels in the baseband.

### **VCXO and PLL**

The VCO frequency is locked by a PLL (phase locked loop) into a stable frequency source given by a VCXO. The frequency of the VCXO is in turn locked into the frequency of the base station with the help of an AFC (automatic frequency control) voltage, which is generated in the UEM. The reference frequency is 26 MHz.

The VCXO also provides a 26 MHz system clock for the digital baseband.

The PLL is located in PMB3258 and it is controlled via the RFBUS.



## 9 — Schematics

(This page left intentionally blank.)

## Table of Contents

Schematics.....9-4

### List of Figures

Figure 153 UPP, UEM, Combo memory, Radio, SIM (1jv\_50e).....9-4  
Figure 154 UI, keyboard, Audio (1jv\_50e).....9-5  
Figure 155 RF part (1jv\_50e).....9-6  
Figure 156 Signal overview (1jv\_50e).....9-7  
Figure 157 Component finder (1jv\_50e).....9-8

■ Schematics

UPP, UEM, Combo memory, Radio, SIM

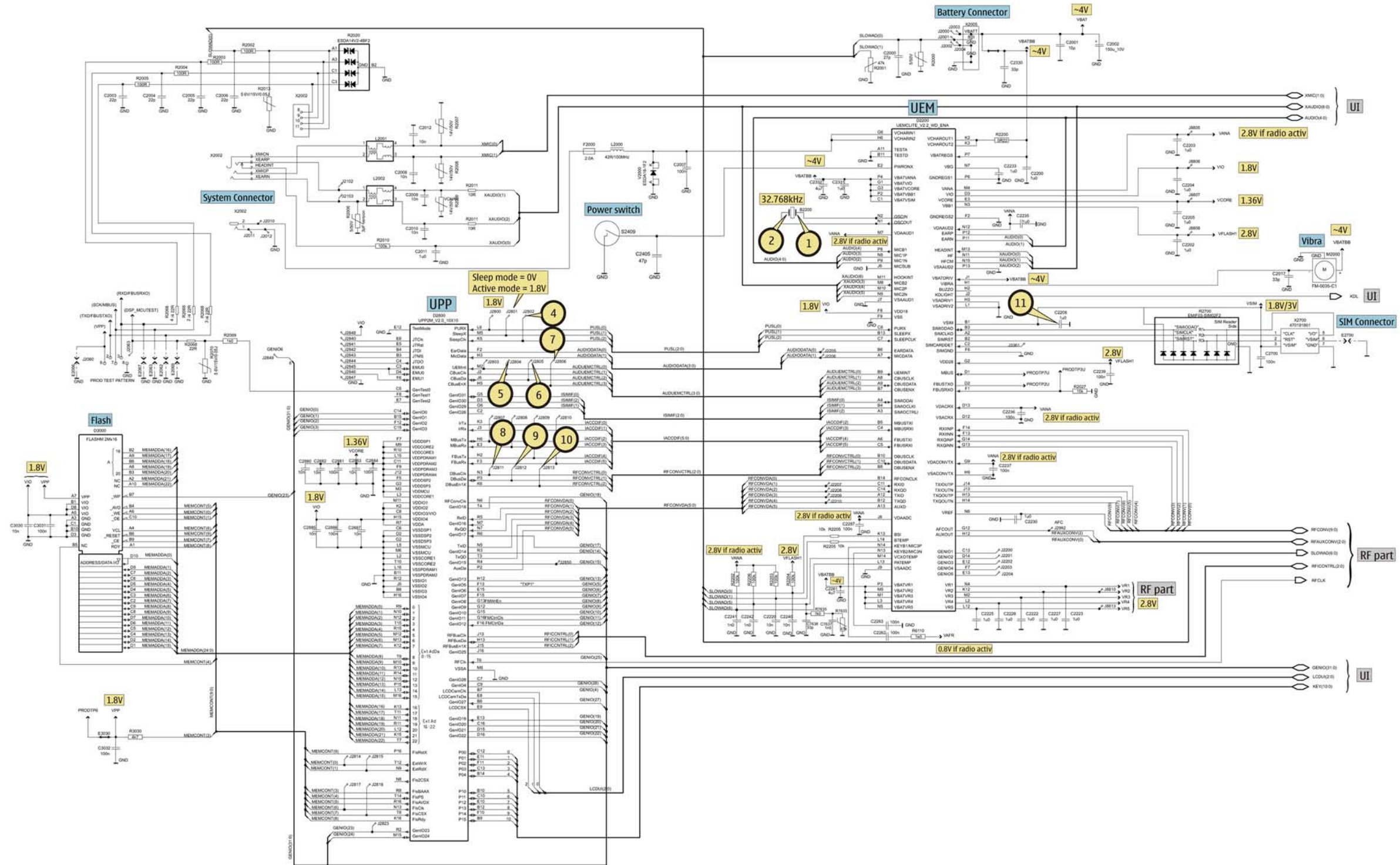

Figure 153 UPP, UEM, Combo memory, Radio, SIM (1jv\_50e)

UI, keyboard, Audio

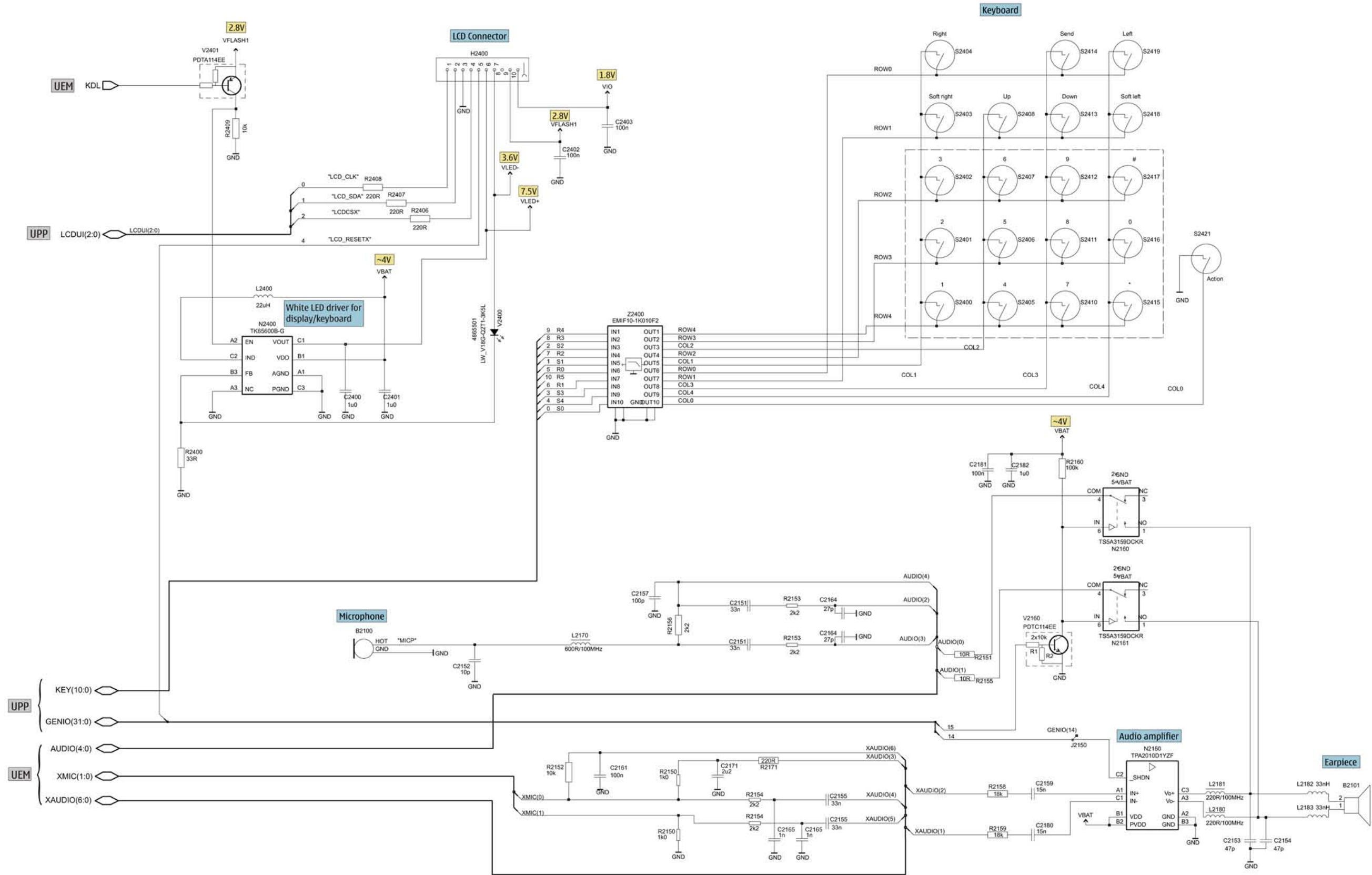

Figure 154 UI, keyboard, Audio (1jv\_50e)

RF part

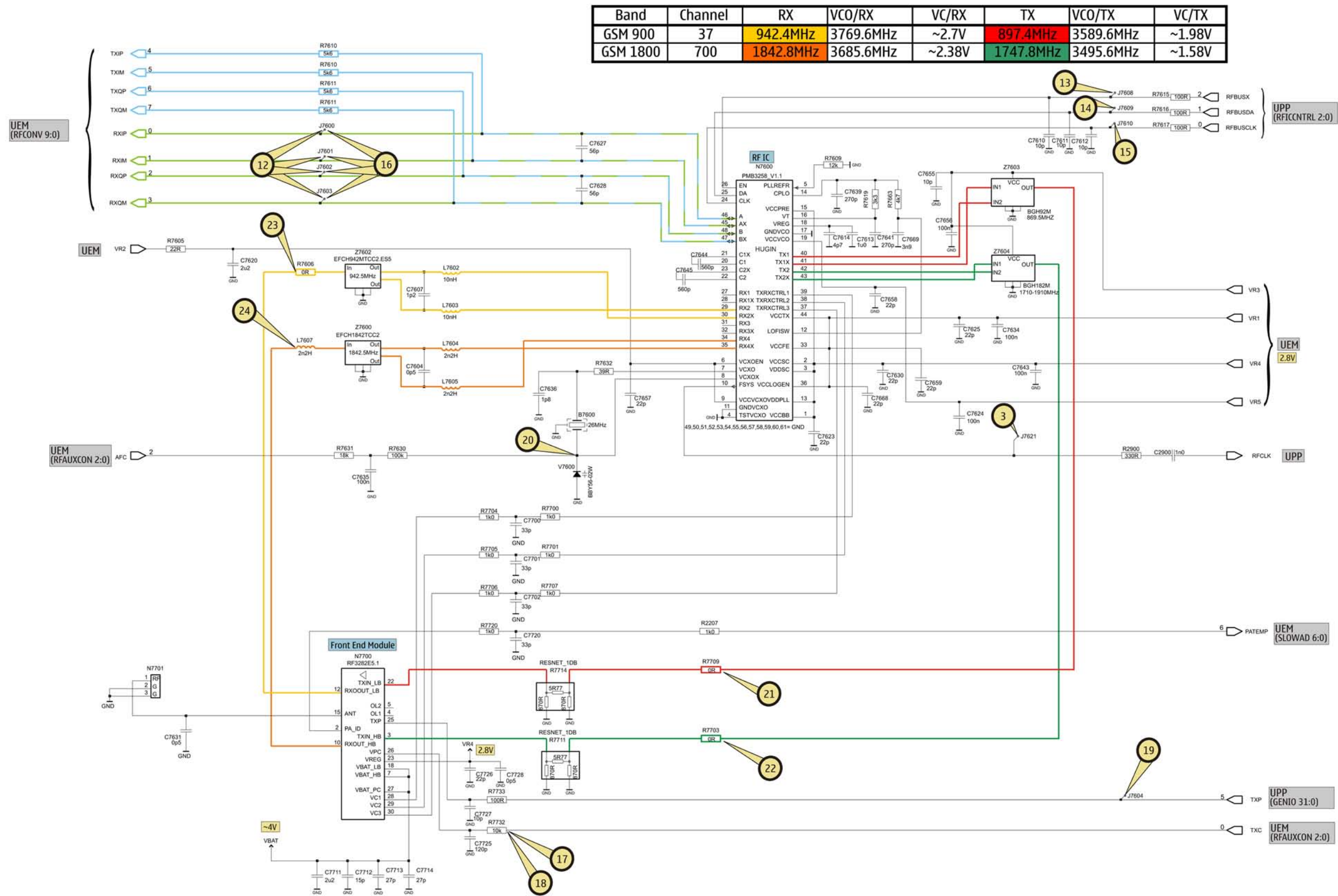

Figure 155 RF part (1jv\_50e)



Signal overview

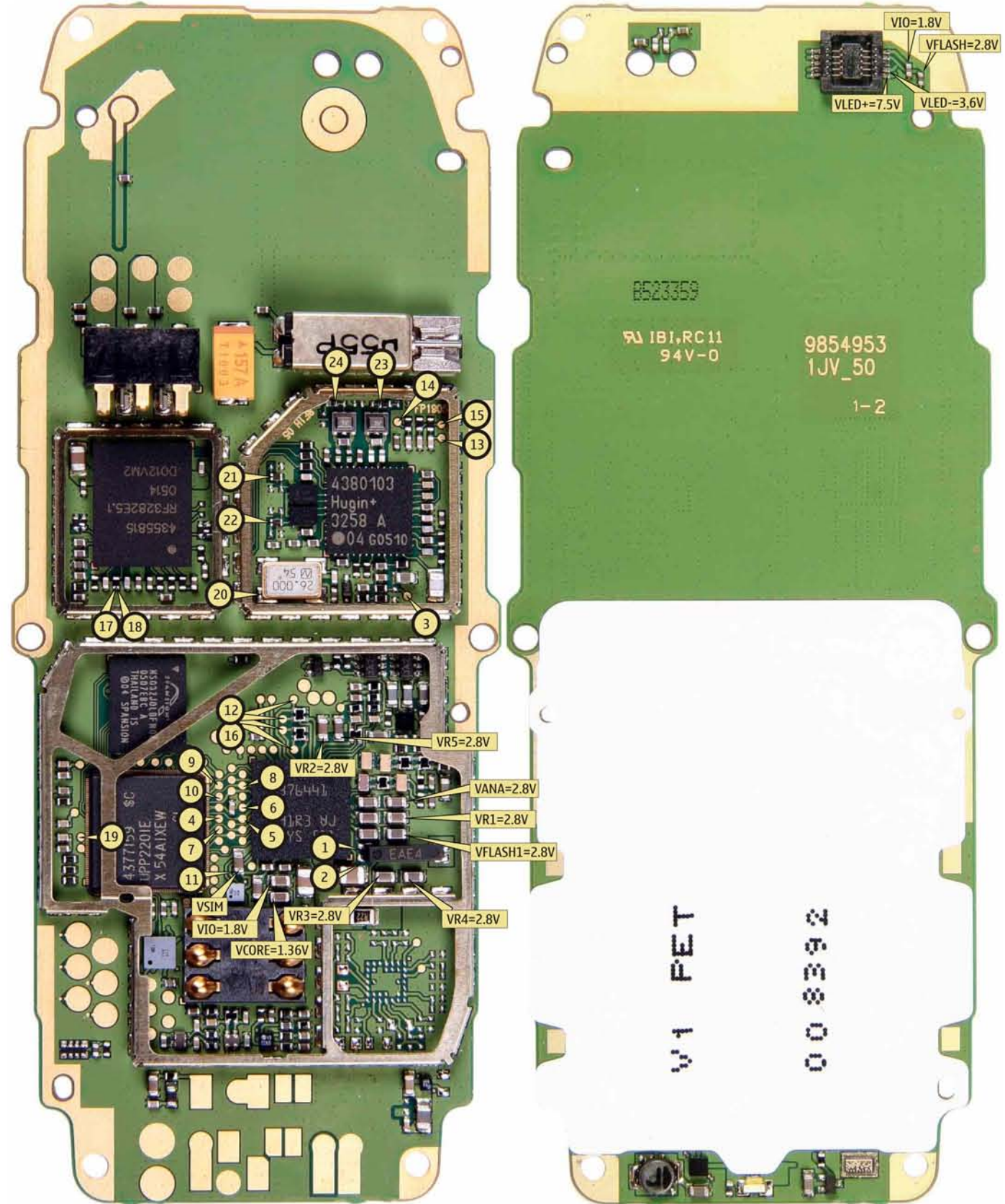
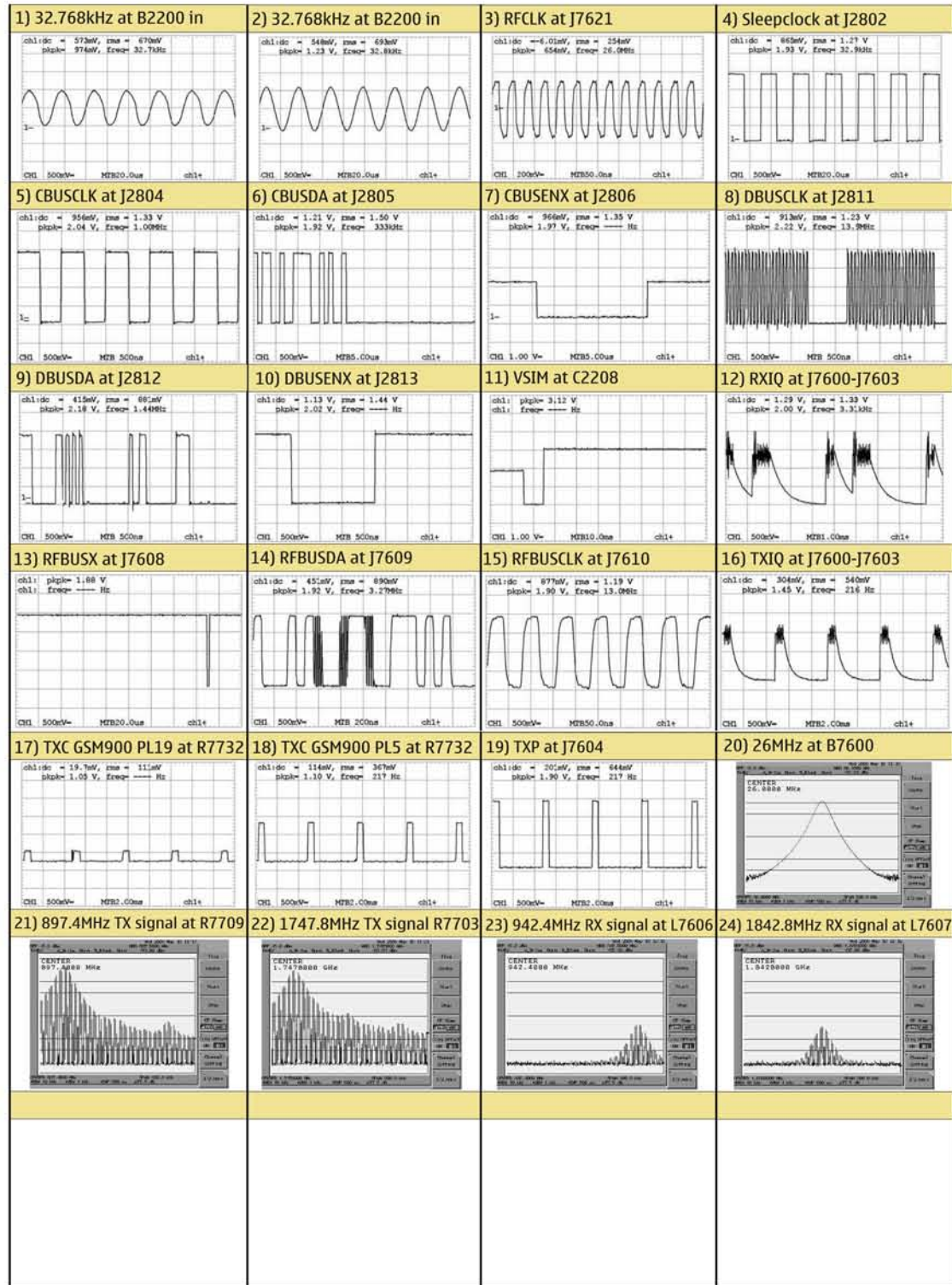

Figure 156 Signal overview (1jv\_50e)



**Component finder**

B	C2239	P5	C7644	J7	J2207	N4	J8808	M6	R2154	N7	V		
B2200	07	C2240	M6	C7645	I7	J2208	N4	J8810	M6	R2155	L6	V2000	S7
B7600	K5	C2241	M6	C7655	I5	J2209	N4	J8813	M6	R2156	07	V2160	L6
C	C2242	M6	C7656	J5	J2210	N4	L	R2158	N7	V2400	U5		
C2000	G3	C2261	P6	C7657	K7	J2800	N4	L2000	T7	R2159	N7	V2401	U3
C2001	G2	C2287	M5	C7658	J7	J2801	N4	L2001	R3	R2160	L6	V7600	K6
C2002	G4	C2330	G2	C7659	I6	J2802	04	L2002	R4	R2171	N8	X	
C2003	S5	C2331	P5	C7668	I6	J2803	N4	L2170	S3	R2200	P6	X2005	G3
C2004	R5	C2332	P5	C7669	K8	J2804	04	L2180	M7	R2202	M7	X2060	T3
C2005	R5	C2400	U4	C7700	K3	J2805	04	L2181	M7	R2203	M7	X2700	Q4
C2006	R5	C2401	U6	C7701	K3	J2806	04	L2182	B6	R2204	M6	Z	
C2007	S7	C2402	C2	C7702	K4	J2807	04	L2183	B6	R2205	M6	Z2400	Q3
C2008	R4	C2403	C2	C7711	I2	J2808	04	L2400	U6	R2206	M7	Z7600	H6
C2009	R4	C2405	P5	C7712	I4	J2809	04	L7602	I7	R2207	L4	Z7602	H7
C2010	R5	C2700	R4	C7713	I2	J2810	04	L7603	I7	R2400	U5	Z7603	J5
C2011	S3	C2880	04	C7714	K3	J2811	N4	L7604	I6	R2406	O2	Z7604	J5
C2012	R4	C2881	P3	C7720	K4	J2812	N4	L7605	I6	R2407	P2		
C2013	R3	C2882	P3	C7725	K3	J2813	N4	L7607	H6	R2408	P2		
C2017	G5	C2883	O2	C7726	J2	J2814	N3	M	R2409	T4			
C2151	N7	C2884	O2	C7727	K2	J2815	N3	M2000	G6	R2700	P4		
C2152	S3	C2885	P3	C7728	K2	J2817	N3	N	R2900	K7			
C2153	B6	C2886	P3	D	J2818	N3	N2150	M7	R3030	O2			
C2154	B7	C2887	O2	D2200	O5	J2823	N4	N2160	L7	R7605	K7		
C2155	N6	C2900	K7	D2800	O3	J2840	P4	N2161	L7	R7606	H7		
C2157	08	C3030	N2	D3000	M3	J2841	P4	N2400	T6	R7609	K6		
C2159	N7	C3031	N2	F	J2842	P4	N7600	J7	R7610	M5			
C2161	N8	C3032	N2	F2000	T7	J2843	P4	N7700	J3	R7611	M5		
C2164	N6	C7604	I6	H	J2844	P4	R	R7615	H8				
C2165	N7	C7607	I7	H2400	C3	J2845	P4	R2000	G3	R7616	H7		
C2171	N8	C7610	I8	J	J2846	P4	R2001	Q3	R7617	H7			
C2180	N7	C7611	I7	J2000	F2	J2847	04	R2002	R5	R7619	J8		
C2181	M7	C7612	I7	J2001	F3	J2848	02	R2003	R5	R7630	K6		
C2182	M7	C7613	I7	J2002	F3	J2849	02	R2004	R5	R7631	K7		
C2200	07	C7614	J7	J2003	F2	J2850	M4	R2005	S5	R7632	K6		
C2202	07	C7620	K7	J2004	F3	J2992	M5	R2006	R5	R7633	K2		
C2203	07	C7623	J7	J2010	T6	J3361	P5	R2007	R4	R7635	K2		
C2204	P5	C7624	J8	J2011	U4	J6161	Q7	R2008	S4	R7663	K8		
C2205	P5	C7625	J6	J2012	T6	J6162	Q7	R2009	R4	R7700	I5		
C2208	P4	C7627	J5	J2060	Q2	J7600	M5	R2010	S3	R7701	I5		
C2220	M7	C7628	J5	J2063	Q2	J7601	M5	R2011	R4	R7703	J5		
C2222	P7	C7630	K6	J2102	T4	J7602	M5	R2013	R5	R7704	K3		
C2223	07	C7631	D3	J2103	S4	J7603	N5	R2020	R5	R7705	K3		
C2225	M6	C7634	I7	J2150	N4	J7604	O2	R2027	R5	R7706	K3		
C2226	P7	C7635	K6	J2200	N5	J7608	I8	R2068	S2	R7707	I5		
C2227	M6	C7636	K6	J2201	N5	J7609	H7	R2069	S2	R7709	I5		
C2230	07	C7637	K2	J2202	N5	J7610	H8	R2070	S2	R7711	J4		
C2233	07	C7638	K2	J2203	N4	J7621	K7	R2150	N7	R7714	J2		
C2235	M7	C7639	J7	J2204	M5	J8805	M5	R2151	M7	R7720	K4		
C2236	M5	C7641	J7	J2205	O4	J8806	N2	R2152	N7	R7732	K2		
C2237	M5	C7643	K6	J2206	O4	J8807	O4	R2153	N7	R7733	K2		

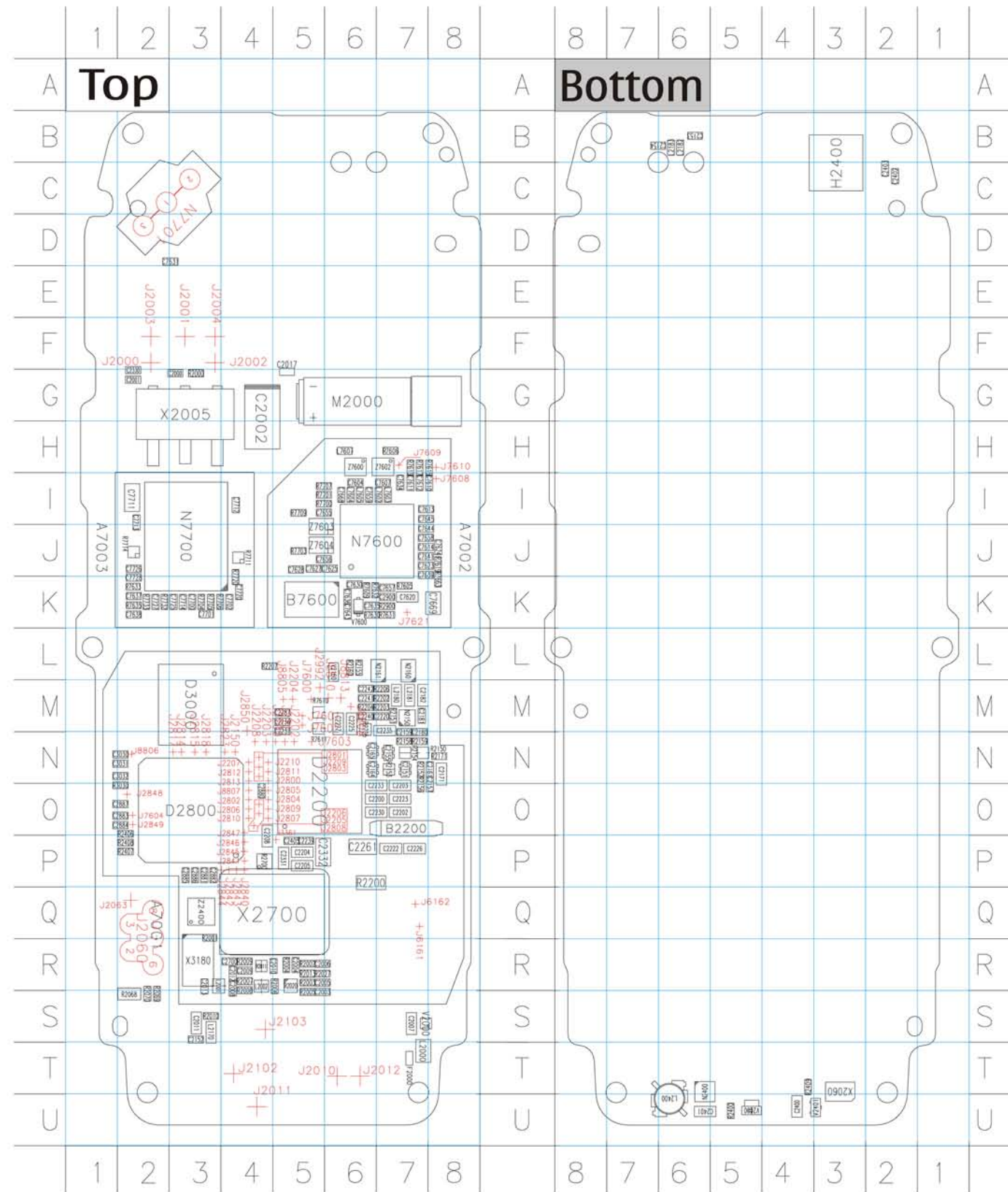

Figure 157 Component finder (1jv\_50e)